

CITY OF
TAMPA, FLORIDA

NOTICE TO BIDDERS, INSTRUCTIONS TO BIDDERS
PROPOSAL, BID BOND, FORM OF NOTICE OF AWARD,
AGREEMENT, PERFORMANCE BOND AND
SPECIFICATIONS

FOR

Contract 22-C-00022

Citywide Roadway Improvements and Street Resurfacing

City of Tampa
CONTRACT ADMINISTRATION DEPARTMENT
TAMPA MUNICIPAL OFFICE BUILDING
306 E. JACKSON STREET - 4TH FLOOR NORTH
TAMPA, FLORIDA 33602

JUNE 2022

CITY OF TAMPA
CONTRACT ADMINISTRATION DEPARTMENT
306 E. Jackson Street 280A4N
Tampa, FL 33602

BID NOTICE MEMO

Electronic Bids are not allowed for these projects.

Physical Bids will be received no later than 1:30 p.m. at the above address on the indicated Date(s) for the following Project(s):

CONTRACT NO.: 22-C-00022; Citywide Roadway Improvements and Street Resurfacing

BID OPENING: 1:30PM, Tuesday, July 12, 2022 **ESTIMATE:** \$7,500,000 **SCOPE:** Construction of various intersection and roadway-related improvements including the installation of traffic signals, roadway widening, drainage improvements.

Bids will be opened in the 4th Floor Conference Room, Tampa Municipal Office Building, 306 E. Jackson Street, Tampa, Florida 33602. The public is not allowed to attend in person.

To view the Bid Opening follow these instructions:
To join the meeting from your computer, tablet or smartphone.

<https://global.gotomeeting.com/join/173279197>

You can also dial in using your phone. (For supported devices, tap a one-touch number below to join instantly.)
United States: +1 (646) 749-3131 - One-touch: tel:+16467493131,,173279197#

Access Code: 173-279-197

Join from a video-conferencing room or system. Dial in or type: 67.217.95.2 or inroomlink.goto.com
Meeting ID: 173 279 197 Or dial directly: 173279197@67.217.95.2 or 67.217.95.2##173279197

New to GoToMeeting? Get the app now and be ready when your first meeting starts:

<https://global.gotomeeting.com/install/173279197>

In accordance with the Americans with Disabilities Act ("ADA") and Section 286.26, Florida Statutes, persons with disabilities needing a reasonable accommodation to participate in this public hearing or meeting should contact the City of Tampa's ADA Coordinator at least 48 hours prior to the proceeding. The ADA Coordinator may be contacted by phone at 813-274-3964, email at TampaADA@tampagov.net, or by submitting an ADA - Accommodations Request online form available at <http://www.tampagov.net/ADARquest>.

Please note that the City of Tampa may not be able to accommodate any request received less than 48 hours before the scheduled public hearing or meeting.

Plans and Specifications and Addenda for this work may be examined at, and downloaded from, www.demandstar.com. Files are also available at <http://www.tampagov.net/contract-administration/programs/construction-project-bidding>.

Email Questions to: contractadministration@tampagov.net .

TABLE OF CONTENTS

BIDDING REQUIREMENTS

Notice to Bidders	N-1
Instructions to Bidders.....	I-1a thru I-4
Insurance Requirements.....	INS-1 thru INS-2
MBD Form 70	1 Page
WMBE-SLBE Availability Contact List.....	ACL-1
Availability Contact List Instructions	ACLI-1

BID FORMS

Proposal.....	P-1 thru P-4
Good Faith Efforts Compliance Plan.....	GFECF
SLBE Solicited	DMI – Solicited
SLBE Utilized.....	DMI – Utilized
Bid Bond	BB-1

CONTRACT FORMS

Agreement	A-1 thru A-15
Public Construction Bond	PB-1 thru PB-3

GENERAL PROVISIONS

General Provisions	G-1 thru G-10
Specific Provisions.....	SPT-1- thru SPT-20
Technical Specifications	TS-1 thru TS-24
Trench Drain, Special Detail.....	Trench Drain -1
Subcontractors Payment Form.....	DMI – Payments
Project Sign.....	Sign-1 thru Sign-2

SPECIFICATION

DIVISION 1

GENERAL REQUIREMENTS

Section 425 - Stormwater Inlets, Manholes and Junction Boxes	W425-1 thru W425-6
--	--------------------

NOTICE TO BIDDERS
CITY OF TAMPA, FLORIDA
Contract 22-C-00022; Citywide Roadway Improvements and Street Resurfacing

Sealed Proposals will be received by the City of Tampa no later than 1:30 P.M., July 12, 2022, in the 4th Floor Conference Room, Tampa Municipal Office Building, 306 E. Jackson Street, Tampa, Florida, there to be publicly opened and read aloud.

The proposed work is to include, but not be limited to, construction of various intersection and roadway-related improvements including the installation of traffic signals, roadway widening, drainage improvements with all associated work required for a complete project in accordance with the Contract Documents.

The Instructions to Bidders, Proposal, Form of Bid Bond, Agreement, Form of Public Construction Bond, Specifications, Plans and other Contract Documents are posted at DemandStar.com. Backup files may be downloaded from <http://www.tampagov.net/contract-administration/programs/construction-project-bidding>. One set may be available for reference at the office of the Contract Administration Department, Municipal Office Building, Fourth Floor North, City Hall Plaza, Tampa, Florida 33602.

Each Proposal must be submitted on the Proposal form included in the Specifications and must be accompanied by a certified check or cashier's check on a solvent bank or trust company in compliance with Section 255.051, Florida Statutes, made payable to the City of Tampa, in an amount of not less than five per cent of the total bid, or a Bid Bond, of like amount, on the form set forth in the Contract Documents, as a guarantee that, if the Proposal is accepted, the Bidder will execute the Proposed Contract and furnish a Public Construction Bond within twenty (20) days after receipt of Notice of Award of Contract.

To be eligible to submit a proposal, a Bidder must hold the required and/or appropriate current license, certificate, or registration (e.g. DBPR license/certificate of authorization, etc.) in good standing at the time of receipt of Bids. **Per Section 489.131, Florida Statutes, Proposals submitted for the construction, improvement, remodeling, or repair of public projects must be accompanied by evidence that the Bidder holds the required and/or appropriate current certificate or registration, unless the work to be performed is exempt under Section 489.103, Florida Statutes.**

The City of Tampa reserves the right to reject any or all Bids and to waive any informalities in the Bid and/or Bid Bond. Acceptance or rejection of Proposals will be made as soon as practicable after the Proposals are received, but the City reserves the right to hold Proposals for ninety (90) days from the date of Opening.

Bid Protest Procedures: Unless subsequently indicated otherwise, in a revised posting on the Department's web page for Construction Project Bidding, the City of Tampa intends to award the referenced project to the lowest bidder listed in the tabulation posted on or about the date of Bid Opening. A bidder aggrieved by this decision may file a protest not later than 4:30 P.M., five (5) business days from the first posting thereof, pursuant to City of Tampa Code Chapter 2, Article V, Division 3, Section 2-282, Procurement Protest Procedures. Protests not conforming therewith shall not be reviewed.

Pursuant to Section 2-282, City of Tampa Code, during the solicitation period, including any protest and/or appeal, NO CONTACT with City officers or employees is permitted from any bidder or proposer, other than as specifically stated in this solicitation and as follows:
Director of the Contract Administration Department (CAD)
Contracts Management Supervisor, Jim Greiner
Contract Officer, Jody Gray
City legal department

Any Requests For Information must be submitted by email to ContractAdministration@tampagov.net

A person or affiliate who has been placed on the convicted vendor list following a conviction for a public entity crime may not submit a bid on a contract to provide any goods or services to a public entity, may not submit a bid on a contract with a public entity for the construction or repair of a public building or public work, may not submit bids on leases of real property to a public entity, may not be awarded or perform work as a contractor, supplier, subcontractor, or consultant under a contract with any public entity, and may not transact business with any public entity in excess of the threshold amount provided in Section 287.017, for CATEGORY TWO for a period of 36 months from the date of being placed on the convicted vendor list." Refer to Section 287.133, Florida Statutes.

Pursuant to Section 287.087, Florida Statutes, under certain circumstances preference may be given to businesses with a drug-free workplace program that meets the requirements of said Section.

INSTRUCTIONS TO BIDDERS
SECTION 1 - SPECIAL INSTRUCTIONS

I-1.01 GENERAL:

The proposed work is the Citywide Roadway Improvements and Street Resurfacing in the City of Tampa, as required for a complete project, as shown on the plans and detailed in the specifications. The work is located on land owned or controlled by the City of Tampa.

To be eligible to submit a proposal, a Bidder must hold the required and/or appropriate current license, certificate, or registration (e.g. DBPR license/certificate of authorization, etc.) in good standing at the time of receipt of Bids. **Per Section 489.131, Florida Statutes, Proposals submitted for the construction, improvement, remodeling, or repair of public projects must be accompanied by evidence that the Bidder holds the required and/or appropriate current certificate or registration, unless the work to be performed is exempt under Section 489.103, Florida Statutes.**

I-1.02 FORM PREPARATION AND PRESENTATION OF PROPOSALS: Replace the second sentence with the following: Submission of the entire specification book is not required.

I-1.03 ADDENDA – Section I-2.03 is replaced with the following: No interpretation of the meaning of the Plans, Specifications, or other Contract Documents will be made to any Bidder orally.

Every request for such interpretation must be in writing, addressed to the City of Tampa, Contract Administration Department, 306 E. Jackson St., 4th Floor, Tampa, Florida 33602 and then emailed to ContractAdministration@tampagov.net. To be given consideration, such request must be received at least seven (7) days prior to the date fixed for the opening of the Proposals. Any and all such interpretations and any supplemental instructions will be in the form of written addenda which, if issued, will be posted on DemandStar.Com and on the Department's web page. Failure of any Bidder to receive any such addenda shall not relieve said Bidder from any obligation under his Proposal as submitted. All addenda so issued shall become part of the Contract Documents.

I-1.04 INSTRUCTIONS TO BIDDERS

SECTION 2 – GENERAL INSTRUCTIONS. Section I-2.07 SIGNATURE AND QUALIFICATIONS OF BIDDERS is replaced with the following:

Proposals must be signed in ink by the Bidder with signature in full. When firm is a Bidder, the Proposal shall be signed in the name of the firm by one or more partners. When a corporation is a bidder the officer signing shall set out the corporate name in full beneath which he shall sign his name and give the title of his office.

If the bidder referred to in Section I-2.07 is a corporation, it must submit; upon request, a copy of its filed Articles of Incorporation. In addition, if the bidder was incorporated in another state, it must establish that it is authorized to do business in the State of Florida. If the bidder is using a fictitious name, it must submit upon request, proof of registration of such name with the Clerk of the Circuit Court of the County where its principal place of business is. Failure to submit what is required is grounds to reject the bid of that bidder.

SECTION 2 – GENERAL INSTRUCTIONS. Section I-2.14 NONDISCRIMINATION IN EMPLOYMENT is changed to add the following to the end of the existing text:

The following provisions are hereby incorporated into any contract executed by or on behalf of the City. Contractor shall comply with the following Statement of Assurance: During the performance of the Contract, the Contractor assures the City, that the Contractor is in compliance with Title VII of the 1964 Civil Rights Act, as amended, the Florida Civil Rights Act of 1992, and the City of Tampa Code of Ordinances, Chapter 12, in that Firm/Contractor does not on the grounds of race, color, national origin, religion, sex, sexual orientation, gender identity or expression, age, disability, familial status, or marital status, discriminate in any form or manner against said Firm's/Contractor's employees or applicants for employment. Contractor understands and agrees that the Contract is conditioned upon the veracity of this Statement of Assurance, and that violation of this condition shall be considered a material breach of the Award/Contract. Furthermore, Contractor herein assures the City that said Contractor will comply with Title VI of the Civil Rights Act of 1964 when federal grant(s) is/are

INSTRUCTIONS TO BIDDERS
SECTION 1 - SPECIAL INSTRUCTIONS

involved. This Statement of Assurance shall be interpreted to include Vietnam-Era Veterans and Disabled Veterans within its protective range of applicability. Firm/Contractor further acknowledges and agrees to provide the City with all information and documentation that may be requested by the City from time to time regarding the solicitation, selection, treatment and payment of subcontractors, suppliers and vendors in connection with this Award/Contract. Firm/Contractor further acknowledges that it must comply with City of Tampa Code of Ordinances, Chapter 26.5.

I-1.05 TIME FOR COMPLETION:

The work shall be arranged to be completed in accordance with a progress schedule approved by the Construction Engineer.

The time for completion of this project, referred in Article 4.01 of the Agreement, shall be 365 consecutive calendar days. The period for performance shall start from the date indicated in the Notice To Proceed.

I-1.06 LIQUIDATED DAMAGES:

The amount of liquidated damages, referred to in Article 4.06 of the Agreement, for completion of this project shall be \$500 per calendar day.

I-1.07 BASIS OF AWARD OF CONTRACT:

The basis of award referred to in Item I-2.11 of Instructions to Bidders shall be the greatest amount of work, which can be accomplished within the funds available as budgeted. The award may be made on the basis of the total bid, base bid, alternates(s) if any, unit bids if any, or any combination thereof deemed to be in the best interest of the City.

Unless all bids are rejected, the award will be made within 90 days after opening proposals.

I-1.08 GROUND BREAKING CEREMONY:

Arrangement may be made by the City in coordination with the Contractor, for construction to commence with a Ground Breaking Ceremony. Details will be discussed at the pre-construction conference.

I-1.09 INSURANCE:

The insurance required for this project shall be as indicated on the attached and incorporated Special Instructions pages beginning with page INS-1 entitled CITY OF TAMPA INSURANCE REQUIREMENTS, which among other things requires the Contractor to provide a Certificate of Insurance to the City prior to commencing work. The City may from time to time use a third-party vendor to manage its insurance certificates and related documentation which vendor may periodically initiate contact, requests for information, etc. on the City's behalf.

I-1.10 TESTING:

The Contractor shall perform all Quality Control (QC) testing to meet the FDOT requirements in the Florida Department of Transportation, JULY 2022 Standard Specifications for Road and Bridge Construction

INSTRUCTIONS TO BIDDERS
SECTION 1 – SPECIAL INSTRUCTIONS

I-1.11 EQUAL BUSINESS OPPORTUNITY PROGRAM (EBO) REQUIREMENTS / PROJECT SUBCONTRACTING GOAL(S)

BIDDERS MUST SUBMIT COMPLETED AND SIGNED CITY OF TAMPA FORMS MBD-10 AND MBD-20 WITH THEIR BIDS. BIDS SUBMITTED WITHOUT THESE COMPLETED FORMS (INCLUDING SIGNATURES) WILL BE DEEMED NON-RESPONSIVE. INSTRUCTIONS ON COMPLETING THE FORMS ARE INCLUDED AFTER EACH FORM IN THIS BID PACKAGE.

THE CHECKED BOX INDICATES SECTION THAT APPLIES TO THIS BID.



SUBCONTRACTING GOAL – (WMBE and SLBE)

In accordance with the City of Tampa's EBO Program, Chapter 26.5, City of Tampa Code, the subcontracting goal(s) has/have been established for subcontracting with City-certified underutilized WMBEs (Women and Minority Business Enterprises) and/or SLBEs (Small Local Business Enterprises) on this project (hereinafter "Goal"). *The Goal is based, in part, upon the availability of City-certified firms to perform the anticipated scope of work (Bid is subject to the subcontracting project goal(s) section for which a corresponding numerical percent is indicated).* **Project Industry Category: Construction**

- Project Goal(s):** _____% **U-WMBE (Underutilized Woman and Minority Business Enterprise) (EBO Program)**
per MBD Form-70 the U-WMBE subcontract Classification for Construction is African American (BBE)
- _____% **SLBE (Small Local Business Enterprise) (EBO Program) only City-certified SLBEs**
- _____ **19% U-WMBE/SLBE Combined (EBO Program)**
per MBD Form-70 the U-WMBE subcontract Classification for Construction is African American (BBE) together with City-certified SLBEs
- _____% **WMBE/SLBE ASPIRATIONAL (EBO Program)** An all-inclusive SLBE/WMBE goal; any City certified firm counts towards goal attainment.

BIDDERS MUST SOLICIT ALL COMPANIES ON THE ATTACHED AVAILABILITY CONTACT LIST at least **five (5) City business days or more prior to bid opening as a first step** to demonstrate Good Faith Efforts to achieve the Goal. Substantive documentation that demonstrates Good Faith Efforts to achieve the Goal **must be submitted with the bid**, including emails, faxes, phone calls, letters, and other communication with City-certified firms. Bidders may explore other potential opportunities for subcontracting by consulting the current directory of all certified firms posted by the City of Tampa at <https://tampa.diversitysoftware.com> as the Availability Contact List may not be inclusive of all firms that could count toward Goal attainment. However, ONLY SUBCONTRACTING with those specific WMBEs designated as "underutilized" by Classification in the appropriate industry category (and, if made applicable by being specifically included in the above Goal, SLBEs) will count toward meeting the Goal. Making Good Faith Efforts through these and other means (not pro-forma) is the responsibility of the Bidder. See the attached Good Faith Effort Compliance Plan (GFCEP) (MBD Form-50) for specific requirements.

GOOD FAITH EFFORT COMPLIANCE PLAN (GFCEP) REQUIRED (MBD FORM-50). When a Goal has been established, the Bidder **must submit** with its bid a Good Faith Effort Compliance Plan (GFCEP) using the attached MBD Form-50 together with supporting documentation as specified therein. **Submittals that do not contain MBD Form-50 when a Goal has been established will be deemed non-responsive.** Additional explanation and documentation is required whenever a City-certified subcontractor's quote is not utilized. Any additional information regarding GFCEP (post-bid) shall be only upon the City's request for clarification of information submitted with bid and not to "cure" omissions or deficiencies of the bid.

NOTE: When U-WMBEs are included in a Goal, only those City-certified subcontractors whose WMBE Classification is designated "underutilized" will count toward Goal attainment. Refer to **MBD Form-70** to identify underutilized WMBEs by subcontract Classification for the applicable project industry category. A prime bidder who is a City-certified WMBE and/or SLBE is not exempt from the **GFCEP MBD Form-50** requirements.



SUBCONTRACTING GOAL – (DBE) FDOT DISADVANTAGED BUSINESS ENTERPRISE PROGRAM

The City of Tampa is required to use the Florida Department of Transportation (FDOT) Disadvantaged Business Enterprise (DBE) program on contracts with Federal Highway Administration (FHWA) funds. Effective October 1, 2017 through to September 30, 2020, the overall FDOT DBE aspirational goal is **10.65%** and is *race neutral*, meaning that FDOT believes the aspirational DBE goal may be achieved entirely through ordinary, competitive procurement methods. Despite the absence of a contract specific DBE goal on this project, the City encourages bidders to seek out and use DBEs and other minority, small businesses. For assistance in identifying certified DBEs, FDOT offers the use of its supportive services program accessed via FDOT's Equal Opportunity Office at <http://www.fdot.gov/equalopportunity/serviceproviders.shtm>. FDOT DBE rules and regulations apply to this solicitation, including the requirement to report bidder opportunity information in the FDOT Equal Opportunity Compliance (EOC) web-based application within three (3) business days of submission of the bid for ALL subcontractors who quoted bidder for this specific project. The five (5) char/digit LAP Agreement Contract Number for this project is G _____. The web address to the EOC system is: <https://fdotwp1.dot.state.fl.us/EqualOpportunityCompliance/Account.aspx/LogIn?ReturnUrl=%2fEqualOpportunityCompliance>

NOTE: Regardless of FDOT DBE program applicability, for data collection purposes bidder still **must submit** City Forms MBD-10 and MBD-20 completed and signed with its bid or the bid will be deemed non-responsive.

DIVERSITY MANAGEMENT INITIATIVE (DMI) DATA REPORTING FORMS REQUIRED FOR ALL CONTRACTS

Bidder **must submit**, with its bid, completed and signed Forms MBD-10 and MBD-20 to be considered a responsive bid. Specifically, the 'Schedule of All Solicited Sub-(Contractors/Consultants/Suppliers) (Form MBD-10)' listing all subcontractors (including non-certified) solicited and 'Schedule of All -To Be Utilized Sub-(Contractors/Consultants/Suppliers) (Form MBD-20)' listing all subcontractors (including non-certified) to be utilized. Supplemental forms, such as 'Form MBD-40 Official Letter Of Intent' (LOI), can be submitted with the bid or once declared lowest-responsive bidder. After an award, 'DMI Sub-(Contractors/Consultants/Suppliers) Payment Form (Form MBD-30)' is to be submitted with payment requests to report payments to subcontractors and using the on-line automated MBD compliance software system available at <https://tampa.diversitysoftware.com>

For additional information about the WMBE and SLBE programs contact the Minority and Small Business Development Office at 813-274-5522. (3-18)

INSTRUCTIONS TO BIDDERS
SECTION 1 - SPECIAL INSTRUCTIONS

I-1.11 BID SECURITY:

Surety companies shall have a rating of not less than B+ Class VI as evaluated in the most recently circulated Best KeyRating Guide Property/Casualty.

I-1.12 PUBLIC CONSTRUCTION BOND:

The Bidder who is awarded the Contract will be required to furnish a Public Construction Bond upon the form provided herein, equal to 100 percent of the Contract price, such Bond to be issued and executed by (a) surety company(ies) acceptable to the City and licensed to underwrite contracts in the State of Florida. After execution of the Agreement and before commencing work, the Contractor must provide the City a certified copy of the officially recorded Bond.

I-1.13 AGREEMENT

SECTION 2 – POWERS OF THE CITY’S REPRESENTATIVES, new Article 2.05:

Add the following:

Article 2.05 CITY’S TERMINATION FOR CONVENIENCE:

The City may, at any time, terminate the Contract in whole or in part for the City’s convenience and without cause. Termination by the City under this Article shall be by a notice of termination delivered to the Contractor, specify the extent of termination and the effective date.

Upon receipt of a notice of termination, the Contractor shall immediately, in accordance with instructions from the City, proceed with performance of the following duties regardless of delay in determining or adjusting amounts due under this Paragraph:

- (a) cease operations as specified in the notice;
- (b) place no further orders and enter into no further subcontracts for materials, labor, services or facilities except as necessary to complete continued portions of the Contract;
- (c) terminate all subcontracts and orders to the extent they relate to the Work terminated;
- (d) proceed to complete the performance of Work not terminated; and
- (e) take actions that may be necessary, or that the City may direct, for the protection and preservation of the terminated Work.

The amount to be paid to the Contractor by the City because of the termination shall consist of:

- (a) for costs related to work performed on the terminated portion of the Work prior to the effective date including termination costs relative to subcontracts that are properly chargeable to the terminated portion of the Work;
- (b) the reasonable costs of settlement of the Work terminated, including accounting, legal, clerical and other expenses reasonable necessary for the preparation of termination settlement proposals and supporting data; additional costs of termination and settlement of subcontracts excluding amounts of such settlements; and storage, transportation, and other costs incurred which are reasonably necessary for the preservation, protection or disposition of the terminated Work; and
- (c) a fair and reasonable profit on the completed Work unless the Contractor would have sustained a loss on the entire Contract had it been completed.

Allowance shall be made for payments previously made to the Contractor for the terminated portion of the Work, and claims which the City has against the Contractor under the Contract, and for the value of materials supplies, equipment or other items that are part of the costs of the Work to be disposed of by the Contractor.

SECTION 5 – SUBCONTRACTS AND ASSIGNMENTS, Article 5.01, Page A-7, last paragraph:

Change “...twenty-five (25) percent...” to “...fifty-one (51) percent...”

SECTION 8 – CONTRACTOR’S EMPLOYEES, Article 8.03, Page A-9, delete Article 8.03 in its entirety and

Replace with the following new article:

ARTICLE 8.03 EMPLOYMENT OPPORTUNITIES

The Contractor shall, in the performance of the work required to be done under this Contract, employ all workers without discrimination and must not maintain, provide or permit facilities that are segregated.

INSTRUCTIONS TO BIDDERS
SECTION 1 - SPECIAL INSTRUCTIONS

SECTION 10 – PAYMENTS, Article 10.05, Page A-10, 1st Paragraph, 1st Sentence:
Change "...fair value of the work done, and may apply for..." to "...fair value of the work done, and shall apply for..."

SECTION 10 – PAYMENTS, Article 10.05, Page A-10, 1st Paragraph, 1st Sentence:
Change "...fair value of the work done, and may apply for..." to "...fair value of the work done, and shall apply for..." Note: Retainage as referenced in Article 10.05 is limited to a maximum of five percent (5%).

SECTION 11 – MISCELLANEOUS PROVISIONS, Article 11.02, Page A-12, 1st Paragraph, 2nd Sentence:
Delete the 2nd Sentence in its entirety and replace it with the following new 2nd Sentence:

Without limiting application of Article 11.07, below, whenever the Contractor is required or desires to use any design, device, material, or process covered by letters of patent or copyright, the Contractor shall indemnify, defend, and hold harmless the City Indemnified Parties (as defined below) from any and all Claims (as defined below) for infringement by reason of the use of any such patented design, device, tool, material, equipment, or process, to be performed under the Contract and damages which may be incurred by reason of such infringement at any time during the prosecution or after completion of the work.

SECTION 11 – MISCELLANEOUS PROVISIONS, Article 11.03, Page A-12:
Delete Article 11.03 in its entirety and replace with the following new article:
ARTICLE 11.03 INTENTIONALLY OMITTED.

SECTION 11 – MISCELLANEOUS PROVISIONS, Article 11.07, Page A-12:
Delete Article 11.07 in its entirety and replace with the following new article:
ARTICLE 11.07 INDEMNIFICATION PROVISIONS

Whenever there appears in this Agreement, or in the other Contract Documents made a part hereof, an indemnification provision within the purview of Chapter 725.06, Laws of Florida, the monetary limitation on the extent of the indemnification under each such provision shall be One Million Dollars or a sum equal to the total Contract price, whichever shall be the greater.

Contractor releases and agrees to defend, indemnify and hold harmless the City, its officers, elected and appointed officials, employees, and/or agents (collectively, "City Indemnified Parties") from and against any and all losses, liabilities, damages, penalties, settlements, judgments, charges, or costs (including without limitation attorneys' fees, professional fees, or other expenses) of every kind and character arising out of any and all claims, liens, is entitled to indemnification hereunder. This obligation shall in no way be limited in any nature whatsoever by any limitation on the amount or type of Contractor's insurance coverage.

The parties agree that to the extent the written terms of this indemnification are deemed by a court of competent jurisdiction to be in conflict with any provisions of Florida law, in particular Sections 725.06 and 725.08, Florida Statutes, the written terms of this indemnification shall be deemed by any court of competent jurisdiction to be modified in such a manner as to be in fully and complete compliance with all such laws and to contain such limiting conditions or limitations of liability, or to not contain any unenforceable or prohibited term or terms, such that this indemnification shall be enforceable in accordance with and to the maximum extent permitted by Florida law.

The obligation of Contractor under this Article is absolute and unconditional; it is not conditioned in any way on any attempt by a City Indemnified Party to collect from an insurer any amount under a liability insurance policy, and is not subject to any set-off, defense, deduction, or counterclaim that the Contractor might have against the City Indemnified Party. The duty to defend hereunder is independent and separate from the duty to indemnify, and the duty to defend exists regardless of any ultimate liability of Contractor, the City, and any City Indemnified Party. The

INSTRUCTIONS TO BIDDERS
SECTION 1 - SPECIAL INSTRUCTIONS

duty to defend arises immediately upon presentation of a Claim by any party and written notice of such Claim being provided to Contractor. Contractor's defense and indemnity obligations hereunder will survive the expiration or earlier termination of this Contract.

Contractor agrees and recognizes that the City Indemnified Parties shall not be held liable or responsible for any Claims which may result from any actions or omissions of Contractor in which the City Indemnified Parties participated either through providing data or advice and/or review or concurrence of Contractor's actions. In reviewing, approving or rejecting any submissions by Contractor or other acts of Contractor, the City in no way assumes or shares any responsibility or liability of Contractor or any tier of subcontractor/subconsultant/supplier, under this Contract.

In the event the law is construed to require a specific consideration for such indemnification, the parties agree that the sum of Ten Dollars and 00/100 (\$10.00), receipt of which is hereby acknowledged, is the specific consideration for such indemnification and the providing of such indemnification is deemed to be part of the specifications with respect to the services provided by Contractor.

SECTION 11 – MISCELLANEOUS PROVISIONS, Article 11.12, Page A-13:
Change Article 11.12 to add the following new language after existing text:

The City of Tampa is a public agency subject to Chapter 119, Florida Statutes. In accordance with Florida Statutes, 119.0701, Contractor agrees to comply with Florida's Public Records Law, including the following:

1. Contractor shall keep and maintain public records required by the City to perform the services under this Agreement;
2. Upon request by the City, provide the City with copies of the requested records, having redacted records in total or in part that are exempt from disclosure by law or allow the records to be inspected or copied within a reasonable time (with provision of a copy of such records to the City) on the same terms and conditions that the City would provide the records and at a cost that does not exceed that provided in Chapter 119, Florida Statutes, or as otherwise provided by law;
3. Ensure that records, in part or in total, that are exempt or that are confidential and exempt from disclosure requirements are not disclosed except as authorized by law for the duration of the Agreement term and following completion (or earlier termination) of the Agreement if Contractor does not transfer the records to the City;
4. Upon completion (or earlier termination) of the Agreement, Contractor shall within 30 days after such event either transfer to the City, at no cost, all public records in possession of the Contractor or keep and maintain the public records in compliance with Chapter 119, Florida Statutes. If Contractor transfers all public records to the City upon completion (or earlier termination) of the Agreement, Contractor shall destroy any duplicate records that are exempt or confidential and exempt from public records disclosure requirements. If Contractor keeps and maintains public records upon completion (or earlier termination) of the Agreement, Contractor shall meet all applicable requirements for retaining public records. All records stored electronically must be provided to the City in a format that is compatible with the information technology systems of the agency.

The failure of Contractor to comply with Chapter 119, Florida Statutes, and/or the provisions set forth in this Article shall be grounds for immediate unilateral termination of the Agreement by the City; the City shall also have the option to withhold compensation due Contractor until records are received as provided herein.

INSTRUCTIONS TO BIDDERS
SECTION 1 - SPECIAL INSTRUCTIONS

IF CONTRACTOR HAS QUESTIONS REGARDING THE APPLICATION OF CHAPTER 119, FLORIDA STATUTES, TO CONTRACTOR'S DUTY TO PROVIDE PUBLIC RECORDS RELATING TO THIS AGREEMENT, CONTACT THE CUSTODIAN OF PUBLIC RECORDS AT 813-274-8598, JIM.GREINER@TAMPAGOV.NET, AND CONTRACT ADMINISTRATION DEPARTMENT, TAMPA MUNICIPAL OFFICE BUILDING, 4TH FLOOR, 306 E. JACKSON ST. TAMPA, FLORIDA 33602.

I-1.14 Contractors must utilize the U.S. Department of Homeland Security's E-Verify Systems to verify the employment eligibility of all persons employed during the term of the Contract to perform employment duties within the State of Florida and all persons, including subcontractors, assigned by Contractor to perform work pursuant to the contract.

E-Verify. In accordance with Section 448.095, Florida Statutes, the Contractor agrees to register with and utilize the U.S. Department of Homeland Security's E-Verify system to verify the employment eligibility of all new employees hired during the term of the Contract for the services specified in the Contract. The Contractor must also include a requirement in subcontracts that the subcontractor must register with and utilize the E-Verify system to verify the employment eligibility of all new employees hired by the subcontractor during the Contract term. If the Contractor enters into a contract with a subcontractor, the subcontractor must provide the Contractor with an affidavit stating that the subcontractor does not employ, contract with, or subcontract with an unauthorized alien. The Contractor shall maintain a copy of such affidavit for the duration of the Contract. If the City has a good faith belief that the Contractor has knowingly violated Section 448.09(1), Florida Statutes, the City shall terminate the Contract with the Contractor, and the Contractor may not be awarded a contract with the City for at least 1 year after the date on which the Contract was terminated. The Contractor is liable for any additional costs incurred by the City as a result of the termination of the Contract. If the City has a good faith belief that a subcontractor knowingly violated the law, but the Contractor has otherwise complied with the law, the City shall promptly notify the Contractor and order the Contractor to immediately terminate the contract with the subcontractor.

I-1.15 GENERAL PROVISIONS; G-2.02 Copies Furnished to Contractor: Replace the first paragraph with the following:

The Contractor shall acquire for its use copies of the plans and specifications as needed, which may be downloaded from the City's web site, at <http://www.tampagov.net/contract-administration/programs/construction-project-bidding>.

Bidder as part of the solicitation process (and as Contractor if Bidder is successful) may hold, come into possession of, and/or generate certain building plans, blueprints, schematic drawings, including draft, preliminary, and final formats, which depict the internal layout and structural elements of a building, facility, or other structure owned or operated by the City or an agency (singularly or collectively "Exempt Plans"), which pursuant to Section 119.071(3), Florida Statutes, are exempt from Section 119.07(1), Florida Statutes and Section 24(a), Art. I of the Florida State Constitution. Contractor certifies it has read and is familiar the exemptions and obligations of Section 119.071(3), Florida Statutes; further that Contractor is and shall remain in compliance with same, including without limitation maintaining the exempt status of such Exempt Plans, for so long as any Exempt Plans are held by or otherwise in its possession.

I-1.16 PAYMENT DISPUTE RESOLUTION

Any dispute pertaining to pay requests must be presented to the City pursuant to Executive Order 2003-1.

INSTRUCTIONS TO BIDDERS
SECTION 1 - SPECIAL INSTRUCTIONS

I-1.17 SCRUTINIZED COMPANIES CERTIFICATION

Section 287.135, Florida Statutes, prohibits agencies or local governmental entities from contracting for goods or services of any amount with companies that are on the Scrutinized Companies that Boycott Israel List or are engaged in a boycott of Israel, and of \$1 million or more with companies that are on either the Scrutinized Companies with Activities in Sudan List or the Scrutinized Companies with Activities in the Iran Petroleum Energy Sector List, or are engaged in business operations in Cuba or Syria. Specifically, Section 287.135(2), Florida Statutes, states: "A company is ineligible to, and may not, bid on, submit a proposal for, or enter into or renew a contract with an agency or local governmental entity for goods or services of: (a) Any amount if, at the time of bidding on, submitting a proposal for, or entering into or renewing such contract, the company is on the Scrutinized Companies that Boycott Israel List, created pursuant to s. 215.4725, or is engaged in a boycott of Israel; or (b) One million dollars or more if, at the time of bidding on, submitting a proposal for, or entering into or renewing such contract, the company: 1. Is on the Scrutinized Companies with Activities in Sudan List or the Scrutinized Companies with Activities in the Iran Petroleum Energy Sector List, created pursuant to s. 215.473; or 2. Is engaged in business operations in Cuba or Syria."

Upon submitting its bid or proposal, a bidder/proposer: (i) certifies the company is not in violation of Section 287.135, Florida Statutes, and shall not be in violation at the time the company enters into or renews any resulting contract; and (ii) agrees any such resulting contract shall be deemed to contain a provision that allows the City, at its option, to terminate such contract for cause if the company is found to have submitted a false certification, been placed on one or any of the foregoing Lists, been engaged in a boycott of Israel, or been engaged in business operations in Cuba or Syria.

I-1.18 FLORIDA'S PUBLIC RECORDS LAW; DATA COLLECTION

Pursuant to Section 119.071(5)(a)2a, Florida Statutes, social security numbers shall only be collected from Bidders and/or Contractor by the City should such number be needed for identification, verification, and/or tax reporting purposes. To the extent Bidder and/or Contractor collects an individual's social security number in the course of acting on behalf of the City pursuant to the terms and conditions of its Proposal or, if awarded, the Agreement, Bidder and/or Contractor shall follow the requirements of Florida's Public Records Law.

I-1.19 APPRENTICESHIP REQUIREMENTS AND REPORTING FORM

Bidders shall comply with the conditions of the Apprenticeship Requirements and Reporting Form, Ordinance No. 2021-33, incorporated into the Contract and as specified therein.

INSTRUCTIONS TO BIDDERS

SECTION 2 GENERAL INSTRUCTIONS

I-2.01 BIDDER'S RESPONSIBILITY

Before submitting Proposals, Bidders shall carefully examine the entire site of the proposed work and adjacent premises and the various means of approach and access to the site, and make all necessary investigations to inform themselves thoroughly as to the facilities necessary for delivering, placing and operating the necessary construction equipment, and for delivering and handling materials at the site, and inform themselves thoroughly as to all difficulties involved in the completion of all the work in accordance with the Contract Documents.

Bidders must examine the Plans, Specifications, and other Contract Documents and shall exercise their own judgment as to the nature and amount of the whole of the work to be done, and for the bid prices must assume all risk of variance, by whomsoever made, in any computation or statement of amounts or quantities necessary to complete the work in strict compliance with the Contract Documents.

Elevations of the ground are shown on the Plans and are believed to be reasonably correct, but are not guaranteed to be absolutely so and are presented only as an approximation. Bidders shall satisfy themselves as to the correctness of all elevations.

The City may have acquired, for its own use, certain information relating to the character of materials, earth formations, probable profiles of the ground, conditions below ground, and water surfaces to be encountered at the site of the proposed work. This information, if it exists, is on file at the offices of the Department of Public Works and Bidders will be permitted to see and examine this information for whatever value they consider it worth. However, this information is not guaranteed, and Bidders should satisfy themselves by making borings or test pits, or by such other methods as they may prefer, as to the character, location, and amounts of water, peat, clay, sand, quicksand, gravel, boulders, conglomerate, rock, gas or other material to be encountered or work to be performed.

Various underground and overhead structures and utilities are shown on the plans. The location and dimensions of such structures and utilities, where given, are believed to be reasonably correct, but do not purport to be absolutely so. These structures and utilities are plotted on the Plans for the information of the Bidders, but information so given is not to be construed as a representation or assurance that such structures will be found or encountered as plotted, or that such information is complete or accurate.

I-2.02 FORM, PREPARATION AND PRESENTATION OF PROPOSALS

Each Proposal shall be submitted upon the Proposal Form and in accordance with the instructions included herein. The Proposal Form must not be detached herefrom. All blank spaces for bid prices must be filled in, in both words and figures, with the unit or lump sum prices, or both, for which the Proposal is made. The computed total price for each unit price Contract Item shall be determined by multiplying the estimated quantity of the item, as set forth in the Proposal Form, by the corresponding unit price bid for such item. The resulting product shall be entered in the appropriate blank space under the column headed "Computed Total Price for Item". The lump sum price bid for each lump sum price Contract Item shall also be entered in the column headed "Computed Total Price for Item". If a Proposal contains any omissions, erasures, alterations, additions, or items not called for in the itemized Proposal, or contains irregularities of any kind, such may constitute sufficient cause for rejection of the Proposal. In case of any discrepancy in the unit price or amount bid for any item in the Proposal, the price as expressed in written words will govern. In no case is the Agreement Form to be filled out or signed by the Bidder.

In the case of certain jobs bid Lump Sum a "Schedule of Unit Prices" must be filled out as an attachment to the Lump Sum proposal. These prices may be used as a guide for the negotiation of change orders, at the City's option.

The proposal must be signed and certified and be presented on the prescribed form in a sealed envelope on/or before the time and at the place stated in the Notice of Bidders, endorsed with the name of the person, firm or corporation presenting it, the date of presentation, and the title of the work for which the Proposal is made.

Unless the apparent low bidder is now engaged in or has recently completed contract work for the City of Tampa, he, if requested, shall furnish to the City, after the opening of bids and prior to award, a summary statement of record of construction experience over the past three (3) years with proper supporting evidence, and, if required by the City, shall also furnish a list of equipment and other facilities pertinent to and available for the proper execution of the proposed work, and a statement of financial resources to the extent necessary to establish ability to carry on the proposed work. The City may make further investigations as considered necessary with respect to responsibility of the Bidder to whom it appears may be awarded the Contract.

If forwarded by mail, the sealed envelope containing the Proposal, endorsed as directed above, must be enclosed in another envelope addressed as specified in the Notice to Bidders and sent by registered mail.

I-2.03 ADDENDA AND INTERPRETATIONS

No interpretation of the meaning of the Plans, Specifications, or other Contract Documents will be made to any Bidder orally.

Every request for such interpretation must be in writing, addressed to the Contract Administration Department, Tampa Municipal Office Building, 4th Floor North, City Hall Plaza, Tampa, Florida 33602. To be given consideration, such request must be received at least seven (7) days prior to the date fixed for the opening of the Proposals. Any and all such interpretations and any supplemental instructions will be in the form of written addenda which, if issued, will be sent by certified mail, with return receipt requested, to all prospective bidders at the respective addresses furnished, for such purposes, not later than three (3) working days prior to the date fixed for the opening of the Proposals, and if requested, a copy will be delivered to the prospective bidder's representative. Failure of any Bidder to receive any such addenda shall not relieve said Bidder from any obligation under his Proposal as submitted. All addenda so issued shall become part of the Contract Documents.

I-2.04 BID SECURITY

Each Proposal must be accompanied by a certified or cashier's check issued by a solvent bank or trust company and payable at sight to the City of Tampa, in compliance with Section 255.051 Florida Statutes, or a Bid Bond upon the form provided herein, in an amount of not less than five percent of the sum of the computed total amount of the Bidder's Proposal as a guarantee that if the Proposal is accepted, the Bidder will execute and fill in the proposed Contract and Public Construction Bond within twenty (20) days after notice of award of the Contract. Certified checks shall have all necessary documentary revenue stamps attached if required by law. Surety on Bid Bonds shall be a duly authorized surety company authorized to do business in the State of Florida, and all such Bonds shall be issued or countersigned by a local resident producing agent, and satisfactory evidence of the authority of the person or persons executing such Bond to Execute the same shall be submitted with the Bond. Bid Bonds shall be issued by a surety company acceptable to the City.

Within ten (10) days after the opening of Proposals, the bid security of all but the three lowest Bidders will be returned. The bid security of the remaining two Bidders whose Proposals are not accepted will be

returned within ten (10) days after the execution of the Contract, or, if no such Contract has been executed, within ninety (90) days after the date of opening Proposals. The bid security of the Bidder whose Proposal is accepted will be returned only after he has duly executed the Contract and furnished the required Public Construction Bond and insurance.

Should it be necessary for the City to retain the bid security and said bid security is in the form of checks, the checks of these Bidders will be returned if replaced by Bid Bonds in an amount equal to the amount of the checks of such Bidders in such form and issued by a surety company acceptable to the City.

A Bidder may withdraw his Proposal before the time fixed for the opening of Proposals, without prejudice to himself, by communicating his purpose, in writing, to the Mayor and City Council, and when his communication is received, the Proposal will be handed to him or his authorized agent unopened. No Bidder may withdraw his Proposal within ninety (90) days after the day of opening Proposals.

The Bidder whose Proposal is accepted shall enter into a written contract, upon the Agreement form included herein, for the performance of the work and furnish the required Public Construction Bond within twenty (20) days after written notice by the City of Award of Contract has been served on such Bidder personally or after receipt of the written notice by registered mail to such Bidder at the address given in his Proposal.

If the Bidder to whom a Contract is awarded refuses or neglects to execute it or fails to furnish the required Public Construction Bond within twenty (20) days after receipt by him of the Notice of Award of Contract, the amount of his bid security shall be forfeited and shall be retained by the City as liquidated damages, and not as a penalty, it being now agreed that said sum is a fair estimate of the amount of damages that the City will sustain in case said Bidder fails to enter into a Contract and furnish the required Public Construction Bond. If a Bid Bond was furnished, the full amount of the Bond shall become due and payable as liquidated damages caused by such failure. The full amount of the bid security shall be forfeited as liquidated damages without consideration of the fact that an award may be less than the full amount of the Bidder's Proposal, excepting that the award shall be within the conditions of said Proposal relating to the basis of consideration for an award. No plea of mistake in the bid or misunderstanding of the conditions of forfeiture shall be available to the Bidder for the recovery of his deposit or as a defense to any action based upon the neglect or refusal to execute a contract.

I-2.05 LAWS AND REGULATIONS

The Bidder who is awarded the Contract must comply with all laws of the State of Florida, and all applicable Ordinances of the City of Tampa respecting labor and compensation and with all other statutes, ordinances, rules and regulations applicable and having the force of law.

I-2.06 PUBLIC CONSTRUCTION BOND

The Bidder who is awarded the Contract will be required to furnish a Public Construction Bond upon the form provided herein, equal to 100 percent of the Contract price, such Bond to be executed by a surety company acceptable to the City of Tampa and licensed to underwrite contracts in the State of Florida. Surety companies shall have a rating of not less than: B+ Class VI as evaluated in the most recently circulated BEST'S KEY RATING GUIDE PROPERTY-LIABILITY.

I-2.07 SIGNATURE AND QUALIFICATIONS OF BIDDERS

Proposals must be signed in ink by the Bidder with signature in full. When a firm is a Bidder, the Proposal shall be signed in the name of the firm by one or more of the partners. When a corporation is a Bidder the officer signing shall set out the corporate name in full beneath which he shall sign his name and give the title of his office. The Proposal shall also bear the seal of the corporation attested by its secretary. Anyone signing the Proposal as agent must file with it legal evidence of his authority to do so.

Bidders who are nonresident corporations shall furnish to the City a

duly certified copy of their permit to transact business in the State of Florida, signed by the Secretary of State, within ten days of the notice to do so. Such notice will be given to Bidders who are nonresident corporations, to whom it appears an award will be made, and the copy of the permit must be filed with the City before the award will be made. Failure to promptly submit this evidence of qualification to do business in the State of Florida may be basis for rejection of the Proposal.

I-2.08 REJECTION OF PROPOSALS

The City reserves the right to reject any Proposal if investigation of the Bidder fails to satisfy the City that such Bidder is properly qualified to carry out the obligations and to complete the work contemplated therein. Any or all Proposals will be rejected if there is reason to believe that collusion exists among Bidders. Proposals will be considered irregular and may be rejected if they show serious omissions, alterations in form, additions not called for, conditions or unauthorized alternates, or irregularities of any kind. The City reserves the right to reject any or all Proposals and to waive such technical errors as may be deemed best for the interests of the City.

I-2.09 QUANTITIES ESTIMATED ONLY

The estimate of quantities of the various items of work and materials, if set forth in the Proposal Form, is approximate only and is given solely to be used as a uniform basis for the comparison of Proposals.

The quantities actually required to complete the Contract work may be less or more than so estimated, and if awarded a Contract for the work specified, the Contractor agrees that he will not make any claim for damages or for loss of profits because of a difference between the quantities of the various classes of work assumed for comparison of Proposals and quantities of work actually performed. The City further reserves the right to vary the quantities in any amount.

I-2.10 COMPARISON OF PROPOSALS

Except jobs bid on a "One Lump Sum" basis, proposals will be compared on the basis of a total computed price arrived at by taking the sum of the estimated quantity of each item and the corresponding unit price of each item, and including any lump sum prices on individual items.

The computed total prices for individual Contract Items and the total computed price for the entire Contract, as entered by the Bidder in the Proposal Form, are for convenience only and are subject to correction in the tabulation and computation of the Proposals.

I-2.11 BASIS OF AWARD

The Contract will be awarded, if at all, to the lowest responsible Bidder or Bidders, as determined by the City and by the terms and conditions of the Contract Documents. Unless all bids are rejected, the award will be made within ninety (90) days after the opening of Proposals. The successful Bidder will be required to possess, or obtain, a valid City Occupational License.

I-2.12 INSURANCE REQUIRED

The successful Bidder and his subcontractors will be required to procure and pay for insurance covering the work in accordance with the provisions of Article 6.02 of the Agreement as indicated on special instructions pages beginning with INS-1.

I-2.13 NO ASSIGNMENT OF BID

No Bidder shall assign his bid or any rights thereunder.

I-2.14 NONDISCRIMINATION IN EMPLOYMENT

Contracts for work under this Proposal will obligate the contractors and subcontractors not to discriminate in employment practices.

Bidders must, if requested, submit with their initial bid a signed statement as to whether they have previously performed work subject to the President's Executive Order Nos. 11246 and 11375.

Bidders must, if requested, submit a compliance report concerning their employment practices and policies in order to maintain their eligibility to receive the award of the Contract.

Successful Bidders must, if requested, submit a list of all subcontractors who will perform work on the project and written,

signed statement from authorized agents of the labor pools with which they will or may deal for employees on the work together with supporting information to the effect that said labor pools practices and policies are in conformity with Executive Order No. 11246 and that said labor pools will affirmatively cooperate in or offer no hindrance to the recruitment, employment and equal treatment of employees seeking employment and performing work under the Contract, or a certification as to what efforts have been made to secure such statements when such agents or labor pools have failed or refused to furnish them prior to the award of the Contract.

I-2.15 LABOR STANDARDS

The Bidder's attention is directed to the Contract Provisions of the Labor Standards for federally assisted projects which may be attached to and made a part of the Agreement.

I-2.16 NOTICE TO LABOR UNIONS

If applicable, the successful Bidder will be required to provide Labor Unions and other organizations of workers a completed copy of the form entitled "Notice to Labor Unions or Other Organizations of Workers", and such form may be made a part of the Agreement.

I-2.17 NOTICE TO PROSPECTIVE FEDERALLY-ASSISTED CONSTRUCTION CONTRACTORS

A Certification of Nonsegregated Facilities, as required by the May 9, 1967, Order (32 F.R. 7439, May 19, 1967) on Elimination of Segregated Facilities, by the Secretary of Labor, must be submitted to said Secretary prior to the award of a federally-assisted construction and Contract exceeding \$10,000 which is not exempt from the provisions of the Equal Opportunity Clause. The form of certification may be bound herein following the form of Bid Bond.

Contractors receiving federally-assisted construction Contract awards exceeding \$10,000 which are not exempt from the provisions of the Equal Opportunity Clause will be required to provide for the forwarding of the following notice to prospective subcontractor for supplies and construction contracts where the subcontracts exceed \$10,000 and are not exempt from the provisions of the Equal Opportunity Clause:

NOTICE TO PROSPECTIVE SUBCONTRACTORS OF REQUIREMENT FOR CERTIFICATIONS OF NONSEGREGATED FACILITIES

"A Certification of Nonsegregated Facilities, as required by the May 9, 1967, Order (32 F.R. 7439, May 19, 1967) on Elimination of Segregated Facilities, by the Secretary of Labor, must be submitted prior to the award of a subcontract exceeding \$10,000 which is not exempt from the provisions of the Equal Opportunity Clause."

"Contractors receiving subcontract awards exceeding \$10,000 which are not exempt from the provisions of the Equal Opportunity Clause will be required to provide from the forwarding of this notice to prospective subcontractors for supplies and construction contracts where the subcontracts exceed \$10,000 and are not exempt from the provisions of the Equal Opportunity Clause."

The United States requires a pre-award conference if a proposed construction contract exceeds one million dollars to determine if the the prospective contractor is in compliance with the Equal Employment Opportunity requirements of Executive Order 11246 of September 24, 1965. In such instances, a meeting may be scheduled at which the prospective contractor must specify what affirmative action he has taken or proposed to take to assure equal employment opportunity which must be approved by the United States before award of the contract will be authorized.

Bidders must be prepared to submit an Equal Employment Opportunity (EEO) plan at a pre-award conference. The plan must include bidding opportunities offered by the Bidder to minority subcontractors.

On October 13, 1971, President Nixon issued Executive Order 11246 emphasizing the government's commitment to the promotion of minority business enterprise. Accordingly, the United States is firmly

committed to the utilization of available resources to support this important program. U.S. agencies are most interested in realizing minority participation on the subject. Achieving equal employment opportunity compliance is required through Executive Order 11246. WE cannot emphasize too strongly that minority subcontractors be extended subcontractors bidding opportunities as but one step in your affirmative action policy.

Due to the importance of this contract, U.S. Agencies may conduct an EEO Conference prior to the award of the Contract. It is suggested that the responsive Bidder confirm the minority subcontractors he contacted for bids or quotations in his EEO plan submitted at the conference.

I-2.18 EEO AFFIRMATIVE ACTION REQUIREMENTS

By the submission of a Proposal, each Bidder acknowledges that he understands and will agree to be bound by the equal opportunity requirements of Federal regulations which shall be applicable throughout the performance of work under any contract awarded pursuant to solicitation. Each Bidder agrees that if awarded a contract, he will similarly bind contractually each subcontractor. In policies, each Bidder further understands and agrees that if awarded a contract, he must engage in Affirmative Action directed to promoting and ensuring equal employment opportunity in the work force used under the contract (and he must require contractually the same effort of all subcontractors whose subcontracts exceed \$100,000). The Bidder understands and agrees that "Affirmative Action" as used herein shall constitute a good faith effort to achieve and maintain minority employment in each trade in the on-site work force used on the project. ***** END of SECTION *****

CITY OF TAMPA INSURANCE REQUIREMENTS

Prior to commencing any work or services or taking occupancy under that certain written agreement or award (for purposes of this document, Agreement) between the City of Tampa, Florida (City) and Firm/Awardee/Contractor/Consultant/Lessee/non-City party, etc. (for purposes of this document, Firm) to which this document is attached and incorporated as an Exhibit or otherwise, and continuing during the term of said Agreement (or longer if the Agreement and/or this document so requires), Firm shall provide, pay for, and maintain insurance against claims for injuries to persons (including death) or damages to property which may arise from or in connection with the performance of the Agreement (including without limitation occupancy and/or use of certain property/premises) by Firm, its agents, representatives, employees, suppliers, subtenants, or subcontractors (which term includes sub-consultants, as applicable) of any tier subject to the terms and conditions of this document. Firm's maintenance of insurance coverage as required herein is a material element of the Agreement and the failure to maintain or renew coverage or provide evidence of same (defined to include without limitation Firm's affirmative duty to provide from time to time upon City's request certificates of insurance, complete and certified copies of Firm's insurance policies, forms, and endorsements, information on the amount of claims payments or reserves chargeable to the aggregate amount of coverage(s) whether during the term of the Agreement or after as may be requested by the City in response to an issue or potential claim arising out of or related to the Agreement to which Firm's insurance obligations hereunder may apply or possibly help mitigate) may be treated as a material breach of the Agreement. Should at any time Firm not maintain the insurance coverages required, City at its sole option (but without any obligation or waiver of its rights) may (i) terminate the Agreement or (ii) purchase such coverages as City deems necessary to protect itself (charging Firm for same) and at City's option suspending Firm's performance until such coverage is in place. If Firm does not reimburse City for such costs within 10 days after demand, in addition to any other rights, City shall also have the right to offset such costs from amounts due Firm under any agreement with the City. All provisions intended to survive or to be performed subsequent to the expiration or termination of the Agreement shall survive, including without limitation Firm's obligation to maintain or renew coverage, provide evidence of coverage and certified copies of policies, etc. upon City's request and/or in response to a potential claim, litigation, etc.

The City reserves the right from time to time to modify or waive any or all of these insurance requirements (or to reject policies) based on the specific nature of goods/services to be provided, nature of the risk, prior experience, insurer, coverage, financial condition, failure to operate legally, or other special circumstances. If Firm maintains broader coverage and/or higher limits than the minimums shown herein, the City requires and shall be entitled to such broader coverage and/or higher limits maintained by Firm. Any available insurance proceeds in excess of the specified minimum limits of insurance and coverage shall be available to the City. No representation is made that the minimum insurance requirements are sufficient to cover Firm's interests, liabilities, or obligations. Required insurance shall not limit Firm's liability.

Firm acknowledges and agrees Firm and not the City is the party in the best position to determine applicability (e.g. "IF APPLICABLE"), confirm, and/or verify its insurance coverage. Acceptance by the City, or by any of its employees, representatives, agents, etc. of certificates or other documentation of insurance or policies pursuant to the terms of this document and the Agreement evidencing insurance coverages and limits does not constitute approval or agreement that the insurance requirements have been met or that coverages or policies are in compliance. Furthermore, receipt, acceptance, and/or approval of certificates or other documentation of insurance or policies or copies of policies by the City, or by any of its employees, representatives, agents, etc., which indicate less coverage than required does not constitute a waiver of Firm's obligation to fulfill these insurance requirements.

MINIMUM SCOPE AND LIMIT OF INSURANCE ¹

A. Commercial General Liability (CGL) Insurance on the most current Insurance Services Office (ISO) Form CG 00 01 or its equivalent on an "occurrence" basis (Modified Occurrence or Claims Made forms are not acceptable without prior written consent of the City). Coverage must be provided to cover liability contemplated by the Agreement including without limitation premises and operations, independent contractors, contractual liability, products and completed operations, property damage, bodily, personal and advertising injury, contractual liability, explosion, collapse, underground coverages, personal injury liability, death, employees-as-insureds. Products and completed operations liability coverage maintained for at least 3 years after completion of work. Limits shall not be less than \$1M per occurrence and \$2M general aggregate for Agreements valued at \$2M or less; if valued over \$2M, a general aggregate limit that equals or exceeds the Agreement's value. If a general aggregate limit applies; it shall apply separately to the project/location (ISO CG 2S 03 or 2S 04 or equivalent). **(ALWAYS APPLICABLE)**

B. Automobile Liability (AL) Insurance in accordance with Florida law, as to the ownership, maintenance, and use of all owned, non-owned, leased, or hired vehicles. AL insurance shall not be less than: (a) \$500,000 combined single limit each occurrence bodily injury and property damage for Agreements valued at \$100,000 or less or (b) \$1M combined single limit each occurrence bodily injury and property damage for Agreements valued over \$100,000. If transportation of hazardous material involved, the MCS-90 endorsement (or equivalent). **(ALWAYS APPLICABLE)**

C. Worker's Compensation (WC) & Employer's Liability Insurance for all employees engaged under the Agreement, Worker's Compensation as required by Florida law. Employer's Liability with minimum limits of (a) \$500,000 bodily injury by accident and each accident, bodily injury by disease policy limit, and bodily injury by disease each employee for Agreements valued at \$100,000 and under or (b) \$1M bodily injury by accident and each accident, bodily injury by disease policy limit, and bodily injury by disease each for all other Agreements. **(ALWAYS APPLICABLE)**

D. Excess (Umbrella) Liability Insurance for Agreements valued at \$2M or more, at least \$4M per occurrence in excess of underlying limits and no more restrictive than underlying coverage for all work performed by Firm. May also compensate for a deficiency in CGL, AL, or WC. **(ALWAYS APPLICABLE)**

E. Builder's Risk Insurance for property loss exposure associated with construction/renovation/additions to buildings or structures, including materials or fixtures to be incorporated. Must be "All Risk" form with limits of no less than the project's completed value, have no coinsurance penalties, eliminate the "occupancy clause", cover Firm (together with its contractors, subcontractors of every tier, and suppliers), and name City as a Loss Payee. **(IF APPLICABLE)**

F. Installation Floater coverage for property (usually highly valued equipment or materials such as compressors, generators, etc.) during its installation. Coverage must be "All Risk" including installation and transit for no less than 100% of the installed replacement cost value. **(IF APPLICABLE)**

G. Architects & Engineers Liability/ Professional Liability (E&O)/ Contractors Professional Liability (CPL)/ Medical Malpractice Insurance where Agreement involves Florida-regulated professional services (e.g. architect, engineer, design-builder, CM, accountant, appraiser, investment banker medical professional) at any tier, whether employed or independent, vicarious design liability exposure (e.g. construction means & methods, design supervision), value engineering, constructability assessments/reviews, BIM process, and/or performance specifications. Limits of at least \$1M per occurrence and \$2M aggregate; deletion of design/ build liability exclusions, as applicable, and maintained for at least 3 years after completion of work/services and City's acceptance of same. **(IF APPLICABLE)**

H. Railroad Protective Liability CRPL Insurance for construction within 50ft of operated railroad track(s) or where affects any railroad bridge, trestle, tunnel, track(s) roadbed, or over/under pass. Subject to involved rail road's approval prior to commencement of work. **(IF APPLICABLE)**.

I. Pollution and/or Asbestos Legal Liability Insurance where Agreement involves asbestos and/or environmental hazards/contamination risks (defined broadly, e.g. lead, mold, bacteria, fuel storage, underground work, cleanup (owned or non-owned sites), pollutant generation/transportation, marine/natural resource damage, contamination claim, restitution, business interruption, mold, fungus, lead-based paint, 3rd party claims/removal, etc.), with limits of at least \$1M per occurrence and \$2M aggregate, maintained for at least 3 years after Agreement completion. **(IF APPLICABLE)**

J. Cyber Liability Insurance where Agreement involves portals allowing access to obtain, use, or store data; managed dedicated servers; cloud hosting services; software/hardware; programming; and/or other IT services

¹ "M" indicates million(s), for example \$1M is \$1,000,000

and products are involved. Limits of not less than \$2M per occurrence and \$2M aggregate. Coverage sufficiently broad to respond to duties and obligations undertaken by Firm, and shall include, but not be limited to, claims involving infringement of intellectual property/copyright, trademark, trade dress, invasion of privacy violations, damage to or destruction of electronic information, information theft, release of confidential and/or private information, alteration of electronic information, extortion, virus transmission, and network security. Coverage, as applicable and with sufficient limits to respond, for breach response costs, regulatory fines and penalties, credit monitoring expenses. **(IF APPLICABLE)**

K. Drone/UAV Liability Insurance where Agreements involves unmanned aerial vehicles/drones. Coverage to include products and completed operations, property damage, bodily injury with limits no less than \$1M per occurrence, and \$2M aggregate; may be provided by CGL endorsement subject to City's prior written approval. **(IF APPLICABLE)**

L. Longshore & Harbor Workers' Compensation Act/Jones Act for work being conducted near, above, or on "navigable waters" for not less than the above Employer's Liability Insurance limit. **(IF APPLICABLE)**

M. Garagekeeper/Hangerkeeper/Marina Operator Legal Liability Insurance and/or Hull/P&I Insurance where parking lot, valet, dealership, garage services, towing, etc. and/or operation of a hangar, marina, or air

plane/ship repairer, providing safe berth, air/watercraft storage/docking (on land/ in water), fueling, tours, charters, ferries, dredges, tugs, mooring, towing, boat/aircraft equipment/repair/alteration/maintenance, etc.; cover- age against liability for damage to vehicles air/watercraft, their machinery in Firm's care, custody, or control both private & commercial. Limits at least equal to greater of \$1M, value of max number of vehicles that may be in Firm's custody, or of most costly object in Firm's custody. **(IF APPLICABLE)**

N. Property Insurance and Interruption of Business CIOB) Insurance where premises, building, structure, or improved real property is leased, licensed, or otherwise occupied by Firm. Property Insurance against all risks of loss to any occupant/tenant improvements at full replacement cost with no coinsurance penalty, including fire, water, leak damage, and flood, as applicable, vandalism and malicious mischief endorsements. IOB by which minimum monthly rent will be paid to City for up to 1 year if premises are destroyed, rendered inaccessible or untenable, including disruption of utilities, water, or telecommunications. **(IF APPLICABLE)**

O. Liquor Liability/Host Liquor Liability where Firm directly or indirectly provides alcoholic beverages, limits of at least \$1M per occurrence and \$1M aggregate. **(IF APPLICABLE)**

P. Educators Legal Liability Insurance where day care, after school program, recreational activities, etc. limits per G above. **(IF APPLICABLE)**

ADDITIONAL REQUIREMENTS

ACCEPTABILITY OF INSURERS- Insurance is to be placed with insurers admitted in the State of Florida and who have a current A.M. Best rating of no less than **A:-VII** or, if not rated by A.M. Best, as otherwise approved by the City in advance and in writing.

ADDITIONAL INSURED - **City, its elected officials, departments, officers, officials, employees, and volunteers together with, as applicable, any associated lender of the City shall be covered as additional insureds on all liability coverage** (e.g. CGL, AL, and Excess (Umbrella) Liability) as to liability arising out of work or operations performed by or on behalf of Firm including materials, parts, or equipment furnished in connection with such work or operations and automobiles owned, leased, hired, or borrowed by or on behalf of Firm. Coverage can be provided in the form of an endorsement to Firm's insurance (at least as broad as ISO Form CG 20 10 11 85 or **both** CG 10 20, CG 20 26, CG 20 33, or CG 20 38 **and** CG 20 37 if later revisions used).

CANCELLATION/NON-RENEWAL – Each insurance policy shall provide that at least 30 days written notice must be given to City of any cancellation, intent to non-renew, or material reduction in coverage (except aggregate liability limits) and at least 10 days' notice for non-payment of premium. Firm shall also have an independent duty to notify City in like manner, within 5 business days of Firm's receipt from its insurer of any notices of same. If any policy's aggregate limit is reduced, Firm shall directly take steps to have it reinstated. Notice and proof of renewal/continued coverage/certifications, etc. shall be sent to the City's notice (or Award contact) address as stated in the Agreement with a copy to the following:

- Contract Administration Department, 306 E Jackson St, Tampa, FL 33602 Purchasing Department, 306 E Jackson Street, Tampa, FL 33602
 Other: _____

CERTIFICATE OF INSURANCE (COI) – to be provided to City by insurance carrier prior to Firm beginning any work/services or taking occupancy and, if the insurance expires prior to completion of the work or services or Agreement term (as may be extended), a renewal COI at least 30 days before expiration to the above address(es). COIs shall specifically identify the Agreement and its subject (project, lease, etc.), shall be sufficiently comprehensive to insure City (named as additional insured) and Firm and to certify that coverage extends to subcontractors' acts or omissions, and as to permit the City to determine the required coverages are in place without the responsibility of examining individual policies. **Certificate Holder must be The City of Tampa, Florida.**

CLAIMS MADE – If any liability insurance is issued on a claims made form, Firm agrees to maintain such coverage uninterrupted for at least 3 years following completion and acceptance of the work either through purchase of an extended reporting provision or purchase of successive renewals. The Retroactive Date must be shown and be a date not later than the earlier of the Agreement date or the date performance/occupancy began thereunder.

DEDUCTIBLES/ SELF-INSURED RETENTIONS (SIR) – must be disclosed to City and, if over \$500,000, approved by the City in advance and in writing, including at City's option being guaranteed, reduced, or eliminated (additionally if a SIR provides a financial guarantee guaranteeing payment of losses and related investigations, claim administration, and defense expenses). Firm shall be fully responsible for any deductible or SIR (without limiting the foregoing a policy with a SIR shall provide or be endorsed to provide that the SIR may be satisfied by either the City or named insured). In the event of loss which would have been covered but for a deductible or SIR, City may withhold from any payment due Firm, under any agreement with the City, an amount equal to same to cover such loss should full recovery not be obtained under the policy.

PERFORMANCE- All insurance policies shall be fully performable in Hillsborough County, Florida (the County), and construed in accordance with Florida law. Further, all insurance policies must expressly state that the insurance company will accept service of process in the County and that the exclusive venue for any action concerning any matter under those policies shall be in the appropriate state court of the County.

PRIMARY POLICIES - Firm's insurance coverage shall be primary insurance coverage at least as broad as ISO CG 20 01 04 13 as to the City, its elected officials, departments, officers, employees, and volunteers. Any insurance or self-insurance maintained by the City, its elected officials, departments, officers, employees, and volunteers shall be excess of the Firm's insurance and shall not contribute with it.

SUBCONTRACTORS/INDEPENDENT ASSOCIATES/CONSULTANTS/SUBTENANTS/SUBLICENSEE - **Firm shall require and verify that all such entities maintain insurance meeting all requirements stated herein with the City as an additional insured** by endorsement (ISO FORM CG 20 38, or broader) or otherwise include such entities within Firm's insurance policies. Upon City's request, Firm shall furnish complete and certified copies of copies of such entities' insurance policies, forms, and endorsements.

SUBCONTRACTOR DEFAULT INSURANCE CONTROLLED INSURANCE PROGRAM, WRAP-UP. Use requires express prior written consent of City Risk Manager.

UNAVAILABILITY- To the fullest extent permitted by law, if Firm is out of business or otherwise unavailable at the time a claim is presented to City, Firm hereby assigns to the City all of its right, title and interest (but not any liabilities or obligations) under any applicable policies of insurance.

WAIVER OF SUBROGATION – With regard to any policy of insurance that would pay third party losses, Firm hereby grants City a waiver of any right to subrogation which any insurer of Firm may acquire against the City by virtue of the payment of any loss under such insurance. Firm agrees to obtain any endorsement that may be necessary to affect such waiver, but this provision shall apply to such policies regardless.

WAIVER/RELEASE AGREEMENT – Where Firm has a defined group of persons who might be exposed to harm (e.g. participants in an athletic event/program, volunteers) any waiver or release agreement used by Firm whereby such persons (and their parent/guardian as applicable) discharge Firm from claims and liabilities, shall include the City, its elected officials, departments, officers, officials, employees, and volunteers to the same extent as Firm.

Procurement Guidelines To Implement Minority & Small Business Participation

Underutilized WMBE Primes by Industry Category

FORMAL PROCUREMENT	Construction	Construction-Related	Professional	Non-Professional	Goods
	Black	Asian	Black	Black	Black
	Hispanic	Native Am.	Hispanic	Asian	Hispanic
	Native Am.	Woman	Asian	Native Am.	Asian
	Woman		Native Am.		Native Am.
			Woman		Woman

Underutilized WMBE Sub-Contractors / Sub-Consultants

SUB WORK	Construction	Construction-Related	Professional	Non-Professional	Goods
	Black	Black	Black	Black	Black
		Asian	Hispanic	Asian	Asian
		Native Am.	Asian	Native Am.	Native Am.
		Woman	Native Am.		Woman
			Woman		

Policy

The Guidelines apply to formal procurements and solicitations. WMBE participation will be narrowly-tailored.

Index

- Black = Black/African-American Business Enterprise
- Hispanic = Hispanic Business Enterprise
- Asian = Asian Business Enterprise
- Native Am. = Native American Business Enterprise
- Woman = Woman Business Enterprise (Caucasian)

Industry Categories

Construction is defined as: new construction, renovation, restoration, maintenance of public improvements and underground utilities.

Construction-Related Services are defined as: architecture, professional engineering, landscape architecture, design build, construction management services, or registered surveying and mapping.

Professional Services are defined as: attorney, accountant, medical doctor, veterinarian, miscellaneous consultant, etc.

Non-Professional Services are defined as: lawn maintenance, painting, janitorial, printing, hauling, security guard, etc.

Goods are defined as: all supplies, materials, pipes, equipment, machinery, appliances, and other commodities.

MBD Form-70

Citywide Roadway Improvements and Street Resurfacing

FY 22 Project #22-C-00022

U-WMBE Availability Contact List

(The Underutilized WMBE Industry Category for Construction Subcontracts is BBE)

#'s	Business Name	Phone	Fax	Email	Address 1	City	State	Zip	Business Description	FEIN	Cert. Type	Ethnicity
1	Cornestone Barricades Inc.	352-373-8001	352-377-8976	sevi.falade@cornestonebarricades.com	3201 SW 42nd Street	Gainesville	FL	32608	Maintenance of Traffic	810763816	BBE	African American
3	BUN Construction Co., Inc.	813-931-8270	813-931-9185	bunconstruction@tampabay.rr.com	4135 E. Hillborough Avenue	Tampa	FL	33610	Pavement Marking & Signing	993362663	BBE	African American
4	Barnes, Ferland and Associates, Inc	407-896-8608	407-896-1822	pbarnes@bfaenvironmental.com	1230 Hillcrest Street, Suite 100	Orlando	FL	32803	Stormwater Improvements	993237612	BBE	African American
4	Gilliam Construction LLC	941-723-1000	941-723-1001	ggilliamconstruction@yahoo.com	2315 17th St E	Palmetto	FL	34221	Stormwater Improvements	464098717	BBE	African American
4	MBattle Construction llc	727-214-4301	727-517-3774	moebattle@hotmail.com	470 maple way	safety harbor	FL	34695	Stormwater Improvements	760840117	BBE	African American
4	Mckenzie Contracting	813-454-4429	813-994-5840	SMorton@mckenziecontractingllc.com	7712 E Broadway Ave	Tampa	FL	33619	Stormwater Improvements	463561860	BBE	African American
5	Aviman Management, LLC	302-377-5788	302-543-7403	levi@avimanmanagement.com	550 N Reo Street	Tampa	FL	33609	Sidewalks	320098022	BBE	African American
5	Denson Construction Inc.	863-709-1001	863-709-1071	pete@denson-construction.com	4270 HOLDEN ROAD	LAKELAND	FL	33811	Sidewalks	993571944	BBE	African American
5	E/S Concrete Service, Inc.	727-560-0957	727-821-5029	enorflslyst@yahoo.com	726 E. Harbor Drive	St. Petersburg	FL	33705	Sidewalks	993119582	BBE	African American
5	Excel 4 Llc	407-480-8976	407-480-8976	excel4llc@yahoo.com	318 N. John Young Parkway Suite #6	Kissimmee	FL	34741	Sidewalks	454149926	BBE	African American
6	E/S Concrete Service, Inc.	727-560-0957	727-821-5029	enorflslyst@yahoo.com	726 E. Harbor Drive	St. Petersburg	FL	33705	Curbing	993119582	BBE	African American
7	African American Urban Decay Fund	813-410-4959		info@aautf.com	2111 w saint sophia street	Tampa	FL	33607	Tree Services	464858219	BBE	African American
7	All Natural Extreme Team, LLC	813-765-2318	813-373-5140	xteam100@gmail.com	3717 East 38th Avenue	Tampa	FL	33610	Tree Services	262262940	BBE	African American
7	BAY LIGHT, LLC	813-972-4057		baylightllc25@gmail.com	1717 E Busch Blvd	Tampa	FL	33612	Tree Services	455079825	BBE	African American
7	Best Choice Property Preservation LLC	754-472-7423		Bcproperty@yahoo.com	9042 Indigo breeze ct	Temple terrace	FL	33647	Tree Services	3648335901	BBE	African American
7	Cut-Ups Lawn Service	813-361-8871	813-238-2397	cutupslawnservice@yahoo.com	3217 East Powhatan Ave.	Tampa	FL	33610	Tree Services	11412916	BBE	African American
7	T.C.C Enterprise Inc	813-606-9148	813-237-0396	tcc_inc@live.com	3902 E POWHATAN AVE	TAMPA	FL	33610	Tree Services	463223645	BBE	African American
7	V&C Lawn and Trees, LLC	813-562-8414		vclawncare321@gmail.com	3004 E Idlewild Ave	TAMPA	FL	33610	Tree Services	351459980	BBE	African American
7	Walkers landscape and lawncare services	813-553-0549		bwalker1lcs@gmail.com	9821 e fowler ave	Thonotosassa	FL	33592	Tree Services	843912131	BBE	African American
8	4678 Landscaping Incorporated	813-850-7950	813-991-0304	4678Landscapinginc@gmail.com	11319 VILLAS ON THE GREEN DR	RIVERVIEW	FL	33579	Sodding	842268587	BBE	African American
8	7 Shepards Investments, LLC	813-416-0484		sevenshepardsinvestmentsllc@yahoo.com	10408 Goldenbrook Way	Tampa	FL	33647	Sodding	263264635	BBE	African American
8	BENEMON & BENEMON ENTERPRISES, LLC	813-952-0432		jamesbenemon65@gmail.com	510 HICKORY LAKE DR	BRANDON	FL	33511	Sodding	844660830	BBE	African American
8	BUN Construction Co., Inc.	813-931-8270	813-931-9185	bunconstruction@tampabay.rr.com	4135 E. Hillborough Avenue	Tampa	FL	33610	Sodding	993362663	BBE	African American
8	Cut-Ups Lawn Service	813-361-8871	813-238-2397	cutupslawnservice@yahoo.com	3217 East Powhatan Ave.	Tampa	FL	33610	Sodding	11412916	BBE	African American
8	Lawn Conquerors LLC	813-444-0466	813-000-0000	lawnconquerors@gmail.com	2409 E Annie St	Tampa	FL	33612	Sodding	352605386	BBE	African American
8	T.C.C Enterprise Inc	813-606-9148	813-237-0396	tcc_inc@live.com	3902 E POWHATAN AVE	TAMPA	FL	33610	Sodding	463223645	BBE	African American
8	Trimen Precision Lawn Care, LLC	813-863-9328		account@trimenlandscapes.com	450 S Taylor Rd	Tampa	FL	33610	Sodding	474625126	BBE	African American
8	Walkers landscape and lawncare services	813-553-0549		bwalker1lcs@gmail.com	9821 e fowler ave	Thonotosassa	FL	33592	Sodding	43912131	BBE	African American
8	WC Boxes, Inc.	813-478-1102	813-864-4386	wcindustries2003@gmail.com	17620 Lake Key Drive	Odessa	FL	33556	Sodding	472682190	BBE	African American
8	Williams Landscape Management Co., Inc.	813-628-8048	813-628-8041	tonywilliams@wlmlandscape.com	5710 N 50th St	Tampa	FL	33610	Sodding	993516370	BBE	African American
8	Works of Nature, LLC	813-531-2324		Trj@workofnature.info	1016 E.33rd Ave.	Tampa	FL	33603	Sodding	814965789	BBE	African American

Citywide Roadway Improvements and Street Resurfacing FY 22 Project #22-C-00022 SLBE Availability Contact List

This Certified Contact List is the minimum contacts available and may require further searches for certified firms to meet Good Faith Efforts.

#/s	Business Name	Phone	Fax	Email	Address 1	City	State	Zip	Business Description	FEIN	Cert. Type	Ethnicity
1	Beato Group, Inc.	813-252-0196		Info@BeatoGroup.com	8961 Turnstone Haven Place	Tampa	FL	33619	Maintenance of Traffic	8540039366	SLBE	Hispanic American
1	SAFETY ZONE SPECIALISTS	863-984-1385	863-984-0139	ofcmgr@safetyzonespecialists.com	8341 EPICENTER BLVD	LAKELAND	FL	33809	Maintenance of Traffic	8445197704	SLBE	Caucasian
1	Cornerstone Barricades, Inc.	352-373-8001	352-377-8976	sevi.falade@cornerstonebarricades.com	3201 SW 42nd Street	Gainesville	FL	32608	Maintenance of Traffic	8107638816	SLBE	African American
2	ABSOLUTE EROSION CONTROL, LLC	407-729-5881		KORTIZ@ABSOLUTEEROSION.COM	270 ARBOR DRIVE WEST	PALM HARBOR	FL	34683	Erosion Control	204394426	SLBE	Hispanic American
3	BUN Construction Co., Inc.	813-931-8270	813-931-9185	bunconstruction@tamapabay.rr.com	4135 E. Hillsborough Avenue	Tampa	FL	33610	Pavement Marking & Signing	8933626663	SLBE	African American
3	Green Earth Commercial Contracting Company	813-323-3406		info@gec-3.com	3903 Northdale Blvd. Suite 130W	Tampa	FL	33634	Pavement Marking & Signing	850914893	SLBE	Hispanic American
3	S. A. Selgas Enterprises Inc	813-299-5536		Serjioaselsgas@yahoo.com	6005 Wilshire Dr	Tampa	FL	33615	Pavement Marking & Signing	800896811	SLBE	Hispanic American
4	Austin Construction Group, Inc.	813-917-9267	813-862-1901	kcoats@acgtampa.com	2706 Stallone Drive	Tampa	FL	33605	Stormwater Improvements	861521703	SLBE	Caucasian
4	Gilliam Construction LLC	941-723-1000	941-723-1001	ggilliamconstruction@yahoo.com	2315 17th St E	Palmetto	FL	34221	Stormwater Improvements	864039817	SLBE	African American
4	H.B. Underground Inc	813-455-5815		hugo726bb@gmail.com	11500 N Dale Mabry Hwy	Tampa	FL	33618	Stormwater Improvements	842208449	SLBE	Hispanic American
4	JMI Consulting Solutions LLC d/b/a JMI Site Development Inc.	813-927-2484		jmisitedevelopment@gmail.com	5902 Audubon Manor Blvd	Lithia	FL	33547	Stormwater Improvements	273413832	SLBE	Caucasian
4	MBattle Construction llc	727-214-4301	727-517-3774	mcbattle@hotmail.com	470 maple way	safety harbor	FL	34695	Stormwater Improvements	260840117	SLBE	African American
4	Right of Way Contracting, LLC.	813-309-0724	813-926-9251	kefff1@verizon.net	11205 Tarpon Springs Road	Odessa	FL	33556	Stormwater Improvements	812829280	SLBE	Caucasian
4	Sunrise Utility Construction, Inc.	813-949-3749	813-949-0408	LMBNBS@AOL.COM	P.O. Box 272293	Tampa	FL	33688	Stormwater Improvements	893034012	SLBE	Caucasian
5	AIO ENTERPRISE, LLC	407-466-3689	813-436-5640	luiz@aioenterprise.com	13011 Perdute PL	Temple Terral	FL	33617	Sidewalks	264346308	SLBE	Hispanic American
5	Beato Group, Inc.	813-252-0196		Info@BeatoGroup.com	8961 Turnstone Haven Place	Tampa	FL	33619	Sidewalks	8540039366	SLBE	Hispanic American
5	CARIA CONSTRUCTION, INC	813-304-7158		Carly@pulcoconcrete.com	2010 Chickwood ct.	tampa	FL	33618	Sidewalks	86365283	SLBE	Caucasian
5	E/S Concrete Service, Inc.	727-560-0957	727-821-5029	enorrisvsr@yahoo.com	726 E. Harbor Drive	St. Petersburg	FL	33705	Sidewalks	893119582	SLBE	African American
5	H.B. Underground Inc	813-455-5815		hugo726bb@gmail.com	11500 N Dale Mabry Hwy	Tampa	FL	33618	Sidewalks	842208449	SLBE	Hispanic American
5	JMI Consulting Solutions LLC d/b/a JMI Site Development Inc.	813-927-2484		jmisitedevelopment@gmail.com	5902 Audubon Manor Blvd	Lithia	FL	33547	Sidewalks	273413832	SLBE	Caucasian
5	Quick Construction Solutions, LLC	813-377-9997	813-374-5849	quicks@outlook.com	4501 N. Saint Vincent St.	Tampa	FL	33614	Sidewalks	890972890	SLBE	Hispanic American
5	Sunrise Utility Construction, Inc.	813-949-3749	813-949-0408	LMBNBS@AOL.COM	P.O. Box 272293	Tampa	FL	33688	Sidewalks	893034012	SLBE	Caucasian
5	Tampa Bay Construction & Engineering, Inc.	813-984-9898		tampabayconstructioninc@gmail.com	10503 Palm Cove Ave	Tampa	FL	33647	Sidewalks	893713572	SLBE	Caucasian
5	Velocity Construction, Inc.	813-624-2117	800-807-0314	bill@velocityconstruction.net	1320 E. 137th Ave	Tampa	FL	33613	Sidewalks	743082984	SLBE	Caucasian
6	CARIA CONSTRUCTION, INC	813-304-7158		Carly@pulcoconcrete.com	2010 Chickwood ct.	tampa	FL	33618	Curbing	86365283	SLBE	Caucasian
6	E/S Concrete Service, Inc.	727-560-0957	727-821-5029	enorrisvsr@yahoo.com	726 E. Harbor Drive	St. Petersburg	FL	33705	Curbing	893119582	SLBE	African American
6	H.B. Underground Inc	813-455-5815		hugo726bb@gmail.com	11500 N Dale Mabry Hwy	Tampa	FL	33618	Curbing	842208449	SLBE	Hispanic American
6	JMI Consulting Solutions LLC d/b/a JMI Site Development Inc.	813-927-2484		jmisitedevelopment@gmail.com	5902 Audubon Manor Blvd	Lithia	FL	33547	Curbing	273413832	SLBE	Caucasian
6	Velocity Construction, Inc.	813-624-2117	800-807-0314	bill@velocityconstruction.net	1320 E. 137th Ave	Tampa	FL	33613	Curbing	743082984	SLBE	Caucasian
7	African American Urban Decay Fund	813-410-4959		info@aaudf.com	2111 w saint sophia street	Tampa	FL	33607	Tree Services	864858219	SLBE	African American
7	AIJ Natural Extreme Team, LLC	813-765-2318	813-373-5140	stream100@gmail.com	3717 East 38th Avenue	Tampa	FL	33610	Tree Services	262262940	SLBE	African American
7	BAY LIGHT, LLC	813-972-4057		bavlightllc25@gmail.com	1717 E Busch Blvd	Tampa	FL	33612	Tree Services	855079825	SLBE	African American
7	Best Choice Property Preservation LLC	754-422-7423		bcpproperty@yahoo.com	9042 indigo breeze ct	Temple terrad	FL	33647	Tree Services	864835901	SLBE	African American
7	Cut-Ups Lawn Service	813-361-8871	813-238-2397	cutupslawnservice@yahoo.com	3217 East Powhatan Ave.	Tampa	FL	33610	Tree Services	811412916	SLBE	African American
7	Paynes Environmental Services, LLC	813-677-6822	866-467-9029	paynestrees@cs.com	5617 Causeway Blvd	Tampa	FL	33619	Tree Services	271037046	SLBE	Hispanic American
7	T.C.C Enterprise Inc	813-606-9148	813-237-0396	tcc_inc@live.com	3902 E POWHATAN AVE	TAMPA	FL	33610	Tree Services	863236445	SLBE	African American
7	V&C Lawn and Trees, LLC	813-562-8414		vclawncares321@gmail.com	3004 E Idlewild Ave	TAMPA FL 336	FL	33610	Tree Services	851459980	SLBE	African American
7	Walkers landscape and lawncare services	813-553-0549		bwalker11c@gmail.com	9821 e fowler ave	Thonotosassa	FL	33592	Tree Services	8433912131	SLBE	African American
8	4678 Landscaping Incorporated	813-850-7950		4678landscapinginc@gmail.com	11319 VILLAS ON THE GREEN DR	RIVERVIEW	FL	33579	Sodding	842268587	SLBE	African American
8	7 Shepards Investments, LLC	813-416-0484	813-991-0304	sevishhepardinvestmentsllc@yahoo.com	10408 Goldenbrook Way	Tampa	FL	33647	Sodding	263264635	SLBE	African American
8	AGRO-TURF CORP.	813-741-9253		beatriz@agro-turf.com	11810 Bullfrog Creek Rd	Gibsonton	FL	33534	Sodding	205501762	SLBE	Hispanic American
8	Always Green Landscaping Inc.	813-516-0823		alwaysgreengreenlandscapinginc@gmail.com	6501 Sawyer Court	Tampa	FL	33634	Sodding	820580963	SLBE	Hispanic American
8	Baron's Landscaping Services, Inc.	813-404-1509	813-443-4919	baronslawncare@aol.com	2415 East Slight Avenue	Tampa	FL	33610	Sodding	850837654	SLBE	Hispanic American
8	BENEMON & BENEMON ENTERPRISES, LLC	813-952-0432		jamessbenemont69@gmail.com	510 HICKORY LAKE DR	BRANDON	FL	33511	Sodding	844660830	SLBE	African American
8	BUN Construction Co., Inc.	813-931-8270	813-931-9185	bunconstruction@tamapabay.rr.com	4135 E. Hillsborough Avenue	Tampa	FL	33610	Sodding	8933626663	SLBE	African American
8	Cut-Ups Lawn Service	813-361-8871	813-238-2397	cutupslawnservice@yahoo.com	3217 East Powhatan Ave.	Tampa	FL	33610	Sodding	811412916	SLBE	African American
8	D & J LAWN SERVICES OF LAKEAND LLC	863-859-3525		DANDJLAWNSERVICES@HOTMAIL.COM	575 Old Polk City Road	Lakeland	FL	33809	Sodding	273279070	SLBE	Hispanic American
8	Fresh Start Development, Inc.	813-758-5345	813-333-5949	freshstartdevelop@yahoo.com	5508 N 50th St	Tampa	FL	33610	Sodding	203857845	SLBE	African American
8	Johnson's Excavation & Services, Inc.	813-752-7097	813-719-9052	sales@jescontracting.com	1706 East Trappnell Road	Plant City	FL	33566	Sodding	893031174	SLBE	Caucasian
8	JTCM Inc	813-935-7724		office@lawnsculptures.net	817 S MacDill Ave	Tampa	FL	33609	Sodding	862418914	SLBE	Caucasian
8	Nelson's Tree Farm and Nursery, Inc.	813-462-4663	813-350-9139	kimberly.martinez33@gmail.com	5027 N Lois Ave	Tampa	FL	33614	Sodding	893404710	SLBE	Hispanic American
8	Sunbelt Sod & Grading Company	813-641-9855	813-434-9038	lesley@sunbeltsod.com	819 - 9th St. N.E.	Ruskin	FL	33570	Sodding	834250933	SLBE	Caucasian
8	T.C.C Enterprise Inc	813-606-9148	813-237-0396	tcc_inc@live.com	3902 E POWHATAN AVE	TAMPA	FL	33579	Sodding	863236445	SLBE	African American
8	Tampa Bay Construction & Engineering, Inc.	813-984-9898		tampabayconstructioninc@gmail.com	10503 Palm Cove Ave	Tampa	FL	33647	Sodding	893713572	SLBE	Caucasian
8	Trimen Precision Lawn Care, LLC	813-863-9328		account@trimenlandscap.com	450 S Taylor Rd	Seffner	FL	33534	Sodding	874625126	SLBE	African American
8	Walkers landscape and lawncare services	813-553-0549		bwalker11c@gmail.com	9821 e fowler ave	Thonotosassa	FL	33634	Sodding	843912131	SLBE	African American
8	WC Boxes, Inc.	813-478-1102	813-864-4386	wcindustries2003@gmail.com	17620 Lake Key Drive	Odessa	FL	33610	Sodding	872682190	SLBE	African American
8	Williams Landscape Management Co., Inc.	813-628-8048	813-628-8041	tonywilliams@wmlslandscap.com	5710 N 50th St	Tampa	FL	33511	Sodding	893516370	SLBE	African American
8	Works of Nature, LLC	813-531-2324		Tj@workofnature.info	1016 E 33rd Ave.	Tampa	FL	33610	Sodding	814965789	SLBE	African American

**Citywide Roadway Improvements and Street Resurfacing FY 22
Project #22-C-00022 Non-UWMBE/SLBE Availability Contact List**

This Certified Contact List is the minimum contacts available and may require further searches for certified firms to meet Good Faith Efforts.

#	Business Name	Phone	Fax	Email	Address 1	City	State	Zip	Business Description	FEIN	Cert. Type	Ethnicity
1	Beato Group, Inc.	813-252-0196		Info@BeatoGroup.com	8961 Turnstone Haven Place	Tampa	FL	33619	Maintenance of Traffic	854003966	MBE	Hispanic American
1	Bussey Construction Services, Inc.	813-857-3844		kbussey@busseyconstruction.com	32234 Summerglade Dr	Wesley Chapel	FL	33545	Maintenance of Traffic	864643333	WBE	Caucasian
1	TRAFFIC CONTROL PRODUCTS OF FLORIDA INC	813-621-8484	813-621-4611	kw@trafficontrolproducts.org	5514 CARMACK RD	TAMPA	FL	33610	Maintenance of Traffic	992582822	WBE	Caucasian
1	USA Protek LLC	863-944-1422		dstengel@usaprotek.com	2404 Crews Lake Hills Lp N	Lakeland	FL	33813	Maintenance of Traffic	872299161	WBE	Caucasian
2	ABSOLUTE EROSION CONTROL LLC	407-729-5881		KORTIZ@ABSOLUTEEROSION.COM	270 ARBOR DRIVE WEST	PALM HARBOR	FL	84683	Erosion Control	204394426	MBE	Hispanic American
2	Blacktip Services, Inc.	954-324-5300	321-285-2995	blacktipemail@yahoo.com	52 RILEY RD STE 422	CELEBRATION	FL	84747	Erosion Control	2744431832	WBE	Caucasian
2	Koncept Carma, Inc.	888-346-7779	888-346-7153	kathryn@kcinow.com	4445 Edgewater Dr	Orlando	FL	32804	Erosion Control	871222102	WBE	Caucasian
3	Blacktip Services, Inc.	954-324-5300	321-285-2995	blacktipemail@yahoo.com	52 RILEY RD STE 422	CELEBRATION	FL	84747	Pavement Marking & Signing	2744431832	WBE	Caucasian
3	Bussey Construction Services, Inc.	813-857-3844		kbussey@busseyconstruction.com	32234 Summerglade Dr	Wesley Chapel	FL	33545	Pavement Marking & Signing	864643333	WBE	Caucasian
3	Cornerstone Construction Services, Inc.	407-299-3299	407-299-3294	astone@ccsorlando.com	4205 Edgewater Drive Suite A	Orlando	FL	32804	Pavement Marking & Signing	992864526	MBE	Hispanic American
3	Green Earth Commercial Contracting Company	813-323-3406		info@gec-3.com	3903 Northdale Blvd., Suite 130W	Tampa	FL	33634	Pavement Marking & Signing	850914893	MBE	Hispanic American
3	S. A Selgas Enterprises inc	813-299-5536		Sergioaselgas@yahoo.com	6005 Wilshire Dr	Tampa	FL	33615	Pavement Marking & Signing	800896811	MBE	Hispanic American
4	Carl Hankins, Inc.	813-977-7270	813-977-5419	terrih@chisesinc.com	14512 N. Nebraska Ave.	Tampa	FL	33613	Stormwater Improvements	891400178	WBE	Caucasian
4	F. R. Aleman & Associates, Inc.	305-591-8777	305-599-8749	marketing@fr-aleman.com	8000 S. Orange Avenue	Orlando	FL	32809	Stormwater Improvements	992751524	MBE	Hispanic American
4	Flave A. Williams III Dozer Service, Inc.	727-856-3765	727-856-6298	nwilliams@flavewilliamsdozerservice.com	14717 Hays Road	Spring Hill	FL	84610	Stormwater Improvements	993225884	WBE	Caucasian
4	H.B. Underground Inc	813-455-5815		hugo726b@gmail.com	11500 N Dale Mabry Hwy	Tampa	FL	33618	Stormwater Improvements	842208449	MBE	Hispanic American
4	Integrity Underground Incorporated	786-777-9265		Kgriffith@integrityundergroundinc.com	1770 Iroquois Drive	APOPKA	FL	82703	Stormwater Improvements	832652194	WBE	Caucasian
4	L & S Diversified, LLC	407-681-3836		luz@lssurveyor.com	489 FL-436	Casselberry	FL	82730	Stormwater Improvements	272336599	MBE	Asian American
4	Sunrise Utility Construction, Inc.	813-949-3749	813-949-0408	LMNBOSS@AOL.COM	P.O. Box 272293	Tampa	FL	33688	Stormwater Improvements	993034012	WBE	Caucasian
4	UIT LLC	786-519-4534		uitllc@aol.com	10675 SW 190th St	Miami	FL	33157	Stormwater Improvements	272127262	MBE	Hispanic American
5	AIO ENTERPRISE, LLC	407-466-3689	813-436-5640	luz@aioenterprise.com	13011 Perdue PL	Temple Terrace	FL	33617	Sidewalks	264346308	MBE	Hispanic American
5	Beato Group, Inc.	813-252-0196		Info@BeatoGroup.com	8961 Turnstone Haven Place	Tampa	FL	33619	Sidewalks	854003966	MBE	Hispanic American
5	Blacktip Services, Inc.	954-324-5300	321-285-2995	blacktipemail@yahoo.com	52 RILEY RD STE 422	CELEBRATION	FL	84747	Sidewalks	2744431832	WBE	Caucasian
5	CARIA CONSTRUCTION, INC	813-304-7158		Carly@puleosconcrete.com	2010 Chickwood Ct.	tampa	FL	33618	Sidewalks	863665283	WBE	Caucasian
5	Central Florida Contractors Inc	727-596-0708		sidewalks@aol.com	13345 Pine Bark Ct	Largo	FL	83774	Sidewalks	993119568	MBE	Hispanic American

**Citywide Roadway Improvements and Street Resurfacing FY 22
Project #22-C-00022 Non-UWMBE/SLBE Availability Contact List**

#	Business Name	Phone	Fax	Email	Address 1	City	State	Zip	Business Description	FEIN	Cert. Type	Ethnicity
5	Construction Supply of Southwest Florida, Inc.	941-366-2322	941-366-7435	laura@mytucco.com	2223 12TH STREET	SARASOTA	FL	34237	Sidewalks	260001316	WBE	Caucasian
5	Diamant Development LLC	352-551-3194		diamantdevelopmentllc@gmail.com	905 Spring Valley Rd	Altamonte Springs	FL	32714	Sidewalks	813746486	WBE	Caucasian
5	H.B. Underground Inc	813-455-5815		hugo726b@gmail.com	11500 N Dale Mabry Hwy	Tampa	FL	33618	Sidewalks	842208449	MBE	Hispanic American
5	KAT Materials Inc.	727-834-8655	727-834-8670	orders@katinc.us	6541 Industrial Ave	Port Richey	FL	34668	Sidewalks	831019704	WBE	Caucasian
5	Liberty Concrete Structures, LLC	407-864-2325	407-378-4250	Bforillo@libertyconcretestructures.com	13650 W Colonial Dr	Winter Garden	FL	34787	Sidewalks	825399301	WBE	Caucasian
5	Professional Concrete, Inc.	941-921-3660	941-921-5371	david@professionalconcrete.com	5220 McIntosh Road, Suite 1	Sarasota	FL	34233	Sidewalks	650715612	MBE	Hispanic American
5	Quick Construction Solutions, LLC	813-377-9997	813-374-5849	quickcs@outlook.com	4501 N. Saint Vincent St.	Tampa	FL	33614	Sidewalks	900972890	MBE	Hispanic American
5	Sunrise Utility Construction, Inc.	813-949-3749	813-949-0408	LMNBROSS@AOL.COM	P.O. Box 272293	Tampa	FL	33688	Sidewalks	993034012	WBE	Caucasian
6	CARBA CONSTRUCTION, INC	813-304-7158		Carly@puleosconcrete.com	2010 Chickwood ct.	tampa	FL	33618	Curbing	863665283	WBE	Caucasian
6	Central Florida Contractors Inc	727-596-0708		sidewalks@aol.com	13345 Pine Bark Ct	Largo	FL	33774	Curbing	993119568	MBE	Hispanic American
6	Diamant Development LLC	352-551-3194		diamantdevelopmentllc@gmail.com	905 Spring Valley Rd	Altamonte Springs	FL	32714	Curbing	813746486	WBE	Caucasian
6	H.B. Underground Inc	813-455-5815		hugo726b@gmail.com	11500 N Dale Mabry Hwy	Tampa	FL	33618	Curbing	842208449	MBE	Hispanic American
6	Liberty Concrete Structures, LLC	407-864-2325	407-378-4250	Bforillo@libertyconcretestructures.com	13650 W Colonial Dr	Winter Garden	FL	34787	Curbing	825399301	WBE	Caucasian
6	Professional Concrete, Inc.	941-921-3660	941-921-5371	david@professionalconcrete.com	5220 McIntosh Road, Suite 1	Sarasota	FL	34233	Curbing	650715612	MBE	Hispanic American
7	Greenturf Services, Inc.	813-933-2647	813-348-4204	greenturfs@aol.com	4619 N. Hesperdies St	Tampa	FL	33614	Tree Services	992988557	MBE	Hispanic American
7	Paynes Environmental Services, LLC	813-677-6822	866-467-9029	paynestrees@cs.com	5617 Causeway Blvd	Tampa	FL	33619	Tree Services	271037046	MBE	Hispanic American
8	AGRO-TURF CORP.	813-741-9253		beatriz@agro-turf.com	11810 Bullfrog Creek Rd	Gibsonton	FL	33534	Sodding	205501762	MBE	Hispanic American
8	Always Green Landscaping Inc.	813-516-0823		alwaysgreengreenturf@gmail.com	6501 Sawyer Court	Tampa	FL	33634	Sodding	820580963	MBE	Hispanic American
8	Baron's Landscaping Services, Inc.	813-404-1509	813-443-4919	baronslawncare@aol.com	2415 East Sligh Avenue	Tampa	FL	33610	Sodding	650837654	MBE	Hispanic American
8	Bay to Bay Environmental LLC	813-343-3803	813-343-3803	cielobaytobayenvironmental.com	9605 N. Harfts Dr.	Tampa	FL	33617	Sodding	993798117	MBE	Hispanic American
8	D & J LAWN SERVICES OF LAKE LAND LLC	863-859-3525		DANDJLAWNSERVICES@HOTMAIL.COM	575 Old Polk City Road	Lakeland	FL	33809	Sodding	273279070	MBE	Hispanic American
8	Diamant Development LLC	352-551-3194		diamantdevelopmentllc@gmail.com	905 Spring Valley Rd	Altamonte Springs	FL	32714	Sodding	813746486	WBE	Caucasian
8	Florida Natives Nursery, Inc.	813-754-1900	813-754-4001	office@floridatnativesnursery.com	4115 NATIVE GARDEN DR	PLANT CITY	FL	33565	Sodding	993561539	WBE	Caucasian
8	Fresh Start Development, Inc.	813-758-5345	813-333-5949	freshstartdevelop@yahoo.com	5508 N 50th St	Tampa	FL	33610	Sodding	203857845	MBE	African American
8	JTCM Inc	813-935-7724		office@jawnsculptures.net	817 S MacDill Ave	Tampa	FL	33609	Sodding	962418914	WBE	Caucasian
8	Landscap Maintenance Professionals, Inc.	813-757-6500	813-757-6501	kellywickers@lmppro.com	13050 E US Highway 92	Dover	FL	33527	Sodding	993613665	MBE	Hispanic American
8	Nelson's Tree Farm and Nursery, Inc.	813-842-4663	813-350-9139	kimberly.martinez33@gmail.com	5027 N Lois Ave	Tampa	FL	33614	Sodding	993404710	MBE	Hispanic American
8	Pine Lake Nursery & Landscape, Inc.	813-948-4736	813-948-4914	Janet@pinelakenurseryinc.com	2122 Henley Rd	Lutz	FL	33558	Sodding	993499734	MBE	Hispanic American
8	Sunbelt Sod & Grading Company	813-641-9855	813-434-9038	lesley@sunbeltsod.com	819 - 9th St. N.E.	Ruskin	FL	33570	Sodding	184250933	WBE	Caucasian

Instructions Regarding Use of the WMBE/SLBE Availability Contact List

Bidders must solicit a subcontracting bid from ALL of the firms listed on the WMBE/SLBEs list provided within the Specifications, and provide documentation of emails, faxes, phone calls, letters, or other communication with the firms as a first step in demonstrating Good-Faith Efforts to achieve the goal set for WMBE/SLBE participation on this contract.

The list is formatted to facilitate e-mailing of a solicitation to the listed firms by copying and pasting the email addresses.

The WMBE/SLBE participation Goal is based upon the availability of the certified firms indicated on the contact list. The Goal and Requirements of the City's Equal Business Opportunity Program are stated in the Bid/Contract Document, Specifications.

Contract 22-C-00022; Citywide Roadway Improvements and Street Resurfacing

PROPOSAL

To the Mayor and City Council of the City of Tampa, Florida:

Legal Name of Bidder: _____

Bidder's Fictitious Name, if applicable: _____

Bidder is a/an: Individual Partnership* Joint Venture* LLC Corp. Other:

Bidder is organized under the laws of: State of Florida Other:

Bidder Mailing Address: _____

Bidder's Federal Employee Identification No. (FEI/EIN): _____

Bidder's License No.: _____ Bidder's FDOS (SUNBIZ) Doc. No.: _____
(See Ch. 489. FS; use entity's, individual's only if applicable)

Bidder Contact Name**: _____ Email: _____ Phone: (____) _____

Bidder's own initial application for employment has criminal history screening practices similar in nature to the practices contained in Chapter 12, Article VI, City of Tampa Code (*Responses, whether "Yes" or "No", are for informational purposes only and will not be used as a basis of award or denial, nor as a basis for any protest*): Yes No

The below named person, appearing before the undersigned authority and after being first duly sworn, for him/herself and on behalf of the entity submitting this Proposal does hereby affirm and declare as follows:

- (1) He/She is of lawful age and is authorized to act on behalf of Bidder (the individual, partnership, corporation, entity, etc. submitting this Proposal) and that all statements made in this document are true and correct to the best of my knowledge.
- (2) If Bidder is operating under a fictitious name, Bidder has currently complied with any and all laws and procedures governing the operation of businesses under fictitious names in the State of Florida
- (3) No person or entity other than Bidder has any interest in this Proposal or in the Contract proposed to be entered into.
- (4) This Proposal is made without any understanding, agreement, or connection with any person or entity making Proposal for the same purposes, and is in all respects fair and without collusion or fraud.
- (5) Bidder is not in arrears to the City of Tampa, upon debt or contract, and is not a defaulter, as surety or otherwise, upon any obligation to the City of Tampa.
- (6) That no officer or employee or person whose salary is payable in whole or in part from the City Treasury is, shall be or become interested, directly or indirectly, as a contracting party, partner, stockholder, surety or otherwise, in this Proposal, or in the performance of the Contract, or in the supplies, materials, or equipment and work or labor to which it relates, or in any portion of the profits thereof.
- (7) Bidder has carefully examined and fully understands the Solicitation and has full knowledge of the scope, nature, and quality of the work to be performed; furthermore, Bidder has carefully examined the site of the work and that, from his own investigations, he has satisfied himself as to the nature and location of the work, the character, quality, and quantity of materials and the kinds and extent of equipment and other facilities needed for the performance of the work, the general and local conditions and all difficulties to be encountered, and all other items which may, in any way, affect the work or its performance.
- (8) Bidder (including its principals) has | has NOT been debarred or suspended from contracting with a public entity.
- (9) Bidder has | has NOT implemented a drug-free workplace program that meets the requirements of Section 287.087, Florida Statutes.
- (10) Bidder has carefully examined and fully understands all the component parts of the Contract Documents and agrees Bidder will execute the Contract, provide the required Public Construction Bond, and will fully perform the work in strict accordance with the terms of the Contract and Contract Documents therein referred to for the following prices, to wit:

* If a Partnership or Joint Venture, attach Partnership or Joint Venture Agreement.

** Someone the City may contact with questions/correspondence regarding this Solicitation and/or permits.

**Citywide Roadway Improvements and Street Resurfacing
Contract: 22-C-00022**

Item No.	Description	Unit	Approx.	Unit Price in Words	Unit Price	Total Computed Price
104-10-3	Sediment Barrier	L.F.	170			
104-18	Inlet Protection System	EA	34			
107-1	Litter Removal	AC	0.1			
107-2	Mowing	AC	0.08			
110-1-1	Cleaning and Grubbing	AC	2			
110-4-10	Removal Of Existing Concrete Pavement	S.Y.	2875			
110-21	Tree Protection Barrier	L.F.	160			
120-1	Regular Excavation	C.Y.	46			
SP-120-1	Special Excavation Root Pruning	EA	10			
120-6	Embankment	C.Y.	34			
160-4	Type B Stabilization	S.Y.	225			
285-703	Optional Bas. Base Group 03	S.Y.	105			
285-704	Optional Base. Base Group 04	S.Y.	500			
285-706	Optional Base. Base Group 06	S.Y.	10500			
285-712	Optional Base. Base Group 12	S.Y.	200			
327-70-1	Milling Exist Asph Pavt. 1" Avd Depth	S.Y.	140000			
327-70-3	Milling Exist Asph Pavt. 4 1/2" Avg Depth	S.Y.	2300			
327-70-6	Milling Exist Asph Pavt. 1 1/2" Avg Depth	S.Y.	55350			
334-1-12	Superpave Asphaltic Concrete Traffic B	TN	350			
334-1-13	Superpave Asphaltic Concrete Traffic C	TN	3020			
337-7-80	Asphalt Concrete Friction Course, Traffic B, FC-9.5, PG 76-22	TN	1575			
337-7-82	Asphalt Concrete Friction Course, Traffic C, FC-9.5, PG 76-22	TN	5500			
425-4	Adjust Inlet	EA	12			
425-5	Manhole, Adjust	EA	30			
425-6	Valve Boxes, Adjust	EA	25			
430-174-115	Pipe Culvert, Optional Material, Round, 15'S/CD	L.F.	160			
430-174-124	Pipe Culvert, Optional Material, Round, 24'S/CD	L.F.	120			
430-175-118	Pipe Culvert, Optional Material, Round, 18'S/CD	L.F.	400			
436-1-1	Trench Drain, Standard	L.F.	30			
436-1-2	Trench Drain, Special	L.F.	40			
520-1-7	Concrete Curb & Gutter, Type E	L.F.	2375			
520-1-10	Concrete Curb & Gutter, Type F	L.F.	5700			
520-2-4	Concrete Curb, Type D	L.F.	7350			
520-7-2	Granite Curb, Reset	L.F.	16000			
522-1	Concrete Sidewalk (4" Thick)	S.Y.	2900			
522-2	Concrete Sidewalk (6")	S.Y.	2000			
520-2-1	Concrete Curb and Gutter, Type A	L.F.	1600			
520-3	Concrete Curb and Gutter, Valley	L.F.	2200			
520-5	Traffic Separator, Concrete, Variable Width	S.Y.	450			
523-1	Patterned Pavement, Vehicular Areas	S.Y.	145			
523-1-3	Patterned Pavement, Vehicular Areas- Green Bike Lane	S.Y.	1030			
527-2	Delelabel Warnings	S.F.	880			
570-1-2	Performance Turf, Sod	S.Y.	1200			
654-2-21	Rectangular Rapid Flashing Beacon, F&I, Solar, Complete Sign Assembly, Single Direction	EA	10			
654-2-22	Rectangular Rapid Flashing Beacon, F&I, Solar, Complete Sign Assembly, Back to Back	EA	5			
660-2-101	Loop Assembly, F&I, Type A	AS	16			
660-2-106	Loop Assembly, F&I, Type F	AS	16			
700-1-11	Single Post Sign, F&I Ground Mount, Up To 12 SF	AS	26			
700-1-12	Single Post Sign, F&I Ground Mount, 12-20 SF	AS	23			
700-1-40	Install Single Post Sign	AS	23			
700-1-50	Relocate Existing single post Sign	AS	23			
700-1-60	Single Sign, Post, Remove	AS	23			

Citywide Roadway Improvements and Street Resurfacing Contract: 22-C-00022

Item No.	Description	Unit		Approx.	Unit Price in Words	Unit Price	Total Computed Price	
		EA	EA					
700-3-402	Sign Panel, Install, 12-20 SF			12				
705-11-1	Delinicator Flexible Tubular			160				
706-3	Retro-Reflective Pavement Markers			1780				
710-17	Remove Existing Marking Painted Pavement marking			625				
710-11-101	Painted Pavement Markings, Standard, White, Solid, 6"			13600				
710-11-102	Painted Pavement Markings, Standard, White, Solid, 8"			180				
710-11-123	Painted Pavement Markings, Standard, White, Solid, 12"			600				
710-11-124	Painted Pavement Markings, Standard, White, Solid, 18"			600				
710-11-125	Painted Pavement Markings, Standard, White, Solid, 24"			360				
710-11-131	Painted Pavement Markings, Standard, White, Skip, 6"			13600				
710-11-133	Painted Pavement Markings, Standard, White, Skip, 12"			60				
710-11-160	Painted Pavement Markings, Standard, White, Message or Symbol			23				
710-11-170	Painted Pavement Markings, Standard, White, Arrows			23				
710-11-201	Painted Pavement Markings, Standard, Yellow, Solid, 6"			13600				
710-11-224	Painted Pavement Markings, Standard, Yellow, Solid for Diagonal or Chevron, 18"			120				
710-11-231	Painted Pavement Markings, Standard, Yellow, Skip, 6"			8900				
710-11-290	Painted Pavement Markings, Standard, Yellow, Island Nose			170				
711-11-102	Thermoplastic, Standard, White, Solid 8"			180				
711-11-124	Thermoplastic, Standard, White, Solid, 18"			1380				
711-11-141	Thermoplastic, Standard, White, 2-4 Dotted Guideline 6-10 GAP Extension, 6"			450				
711-11-160	Pavement Messages, Thermoplastic			14				
711-11-170	Directional Arrows, Thermoplastic			18				
711-11-180	Thermoplastic, Standard, White, Yield Line			20				
711-11-224	Thermoplastic, Standard, Yellow, Solid, 18"			1520				
711-11-241	Thermoplastic, Standard, Yellow, 2-4 Dotted Guideline 6-10 Dotted Ext Line, 6"			450				
711-14-123	Thermoplastic, Preformed, White, Solid, 12" for Crosswalk			144				
711-14-125	Thermoplastic, Preformed, White, Solid, 24" for Crosswalk			190				
711-14-141	Thermoplastic, Preformed, White, 2-4 Dotted Guideline on Concrete Surfaces			640				
711-14-160	Thermoplastic, Preformed, White, Message (Bike, SLM, etc.)			68				
711-14-170	Thermoplastic, Preformed, White, Arrow (Bike, etc.)			120				
711-15-101	Thermoplastic, Standard-Open Graded Asphalt Surfaces White, Solid, 6"			15820				
711-16-101	Thermoplastic, Standard-Other Surfaces, White, Solid, 6"			21200				
711-16-102	Thermoplastic, Standard-Other Surfaces, White, Solid, 8"			210				
711-11-124	Thermoplastic, standard, white, solid, 18" for diagonal or chevron			93				
711-16-131	Thermoplastic, Standard-Other Surfaces, White, SKIP, 6" 10-30 SKIP			13600				
711-16-201	Thermoplastic, Standard-Other Surfaces, Yellow, Solid, 6"			24600				
711-16-202	Thermoplastic, Standard-Other Surfaces, Yellow, Solid, 8"			1740				
711-16-231	Thermoplastic, Standard-Other Surfaces, Yellow, SKIP, 6"			8900				
711-17	Thermoplastic Removal, Surface to Remain			250				
SPT-10.02.1	Tree Removal 4 to 12"			3				
SPT-10.02.2	Tree Removal >12 to 18"			3				
SPT-10.02.3	Tree Removal >18 to 24"			2				
SPT-10.02.4	Tree Removal >24" to 36"			1				
SP-8.06.1	Inlet, COT, Curb, Type 1			1				
SP-8.06.2	Inlet, COT, Curb, Type 2			1				
SPT-8.06.4	Inlet, COT, Grate, Type T			1				
SP-8.06.5	Inlet, COT, Grate, Type E			1				
Sub Total								
101-1	Mobilization			1				
102-1	Maintenance of Traffic			1				
SP-11.16	Contingency Allowance			1	seven hundred fifty thousand dollars	\$	750,000.00	
TOTAL								\$750,000.00

Computed Total Price in Words: _____
 _____ dollars and _____ cents.

Computed Total Price in Figures: \$ _____

Bidder acknowledges that the following addenda have been received and that the changes covered by the addendum(s) have been taken into account in this proposal: #1 ____ #2 ____ #3 ____ #4 ____ #5 ____ #6 ____ #7 ____ #8 ____.

Bidder acknowledges the requirements of the City of Tampa's Equal Business Opportunity Program.

Bidder acknowledges that it is aware of Florida's Trench Safety Act (Sections 553.60-553.64, Florida Statutes), and agrees that Bidder together with any involved subcontractors will comply with all applicable trench safety standards. Bidder further acknowledges that included in the various items of this Proposal and the total bid price (as applicable) are costs for complying with the Trench Safety Act. Bidder further identifies the costs and methods summarized below:

	Trench Safety Measure (Description)	Unit of Measure (LF, SY)	Unit Quantity	Unit Cost	Extended Cost
A.	_____	_____	_____	_____	_____
B.	_____	_____	_____	_____	_____
C.	_____	_____	_____	_____	_____
Total Cost: \$				_____	

Accompanying this Proposal is a certified check, cashier's check or Tampa Bid Bond (form included herein must be used) for at least five percent (5%) of the total amount of the Proposal which check shall become the property of the City, or which bond shall become forthwith due and payable to the City, if this Proposal shall be accepted by the City and the Bidder shall fail to enter into a legally binding contract with and to furnish the required Public Construction Bond to the City within twenty (20) days after the date of its receipt of written Notice of Award by the City so to do.

FAILURE TO COMPLETE THE ABOVE MAY RESULT IN THE PROPOSAL BEING DECLARED NON-RESPONSIVE.

[SEAL] Name of Bidder: _____
 Authorized Signature: _____
 Signer's Printed Name: _____
 Signer's Title: _____

STATE OF _____
 COUNTY OF _____

For an entity: The forgoing instrument was Sworn to (or affirmed) and subscribed before me by means of physical presence or online notarization, this _____ day of _____, 20____, by _____ as _____ of _____, a/n Partnership Joint Venture LLC Corp Other: _____, on behalf of such entity. Such individual is Personally Known OR Produced Identification. Type of Identification Produced: _____

For an individual: The forgoing instrument was Sworn to (or affirmed) and subscribed before me by means of physical presence or online notarization, this _____ day of _____, 20____, By _____, Such individual is Personally Known OR Produced Identification. Type of Identification Produced: _____.

[NOTARY SEAL] _____
 Notary Public, State of _____
 Notary Printed Name: _____
 Commission No.: _____
 My Commission Expires: _____



Good Faith Effort Compliance Plan Guidelines

for Women/Minority Business Enterprise/Small Local Business Enterprise Participation
City of Tampa - Equal Business Opportunity Program
(MBD Form 50 – detailed instructions on page 2 of 2)

Contract Name _____ Bid Date _____

Bidder/Proposer _____

Signature _____ Date _____

Name _____ Title _____

The Compliance Plan with attachments is a true account of Good Faith Efforts (GFE) made to achieve the participation goals as specified for Women/Minority Business Enterprises/Small Local Business Enterprises (WMBE/SLBE) on the referenced contract:

The WMBE/SLBE participation **Goal is Met or Exceeded**. See DMI Forms 10 and 20 which accurately report all subcontractors solicited and all subcontractors to-be-utilized.

The WMBE/SLBE participation Goal is **Not Achieved**. The following list is an overview of the baseline GFE action steps already performed. Furthermore, it is understood that these GFE requirements are weighted in the compliance evaluation based on the veracity and demonstrable degree of documentation provided with the bid/proposal:

(Check applicable boxes below. Must enclose supporting documents accordingly with remarks)

- (1) Solicited through reasonable and available means the interest of WMBE/SLBEs that have the capability to perform the work of the contract. The Bidder or Proposer must solicit this interest within sufficient time to allow the WMBE/SLBEs to respond. The Bidder or Proposer must take appropriate steps to follow up initial solicitations with interested WMBE/SLBEs. See DMI report forms for subcontractors solicited. See enclosed supplemental data on solicitation efforts. Qualifying Remarks:
- (2) Provided interested WMBE/SLBEs with adequate, specific scope information about the plans, specifications, and requirements of the contract, including addenda, in a timely manner to assist them in responding to the requested-scope identified by bidder/proposer for the solicitation. See enclosed actual solicitations used. Qualifying Remarks:
- (3) Negotiated in good faith with interested WMBE/SLBEs that have submitted bids (e.g. adjusted quantities or scale). Documentation of negotiation must include the names, addresses, and telephone numbers of WMBE/SLBEs that were solicited; the date of each such solicitation; a description of the information provided regarding the plans and specifications for the work selected for subcontracting; and evidence as to why agreements could not be reached with WMBE/SLBEs to perform the work. Additional costs involved in soliciting and using subcontractors is not a sufficient reason for a bidder/proposer's failure to meet goals or achieve participation, as long as such costs are reasonable. Bidders are not required to accept excessive quotes in order to meet the goal. DMI Utilized Forms for sub-(contractor/consultant) reflect genuine negotiations This project is an RFO/RFP in nature and negotiations are limited to clarifications of scope/specifications and qualifications. See enclosed documentation. Qualifying Remarks:
- (4) Not rejecting WMBE/SLBEs as being unqualified without justification based on a thorough investigation of their capabilities. The WMBE/SLBEs standing within its industry, membership in specific groups, organizations / associations and political or social affiliations are not legitimate causes for rejecting or not soliciting bids to meet the goals. Not applicable. See attached justification for rejection of a subcontractor's bid or proposal. Qualifying Remarks:
- (5) Made scope(s) of work available to WMBE/SLBE subcontractors and suppliers; and, segmented portions of the work or material consistent with the available WMBE/SLBE subcontractors and suppliers, so as to facilitate meeting the goal. Sub-Contractors were allowed to bid on their own choice of work or trade without restriction to a pre-determined portion. See enclosed comments. Qualifying Remarks:
- (6) Made good faith efforts, despite the ability or desire of Bidder/Proposer to perform the work of a contract with its own forces/organization. A Bidder/Proposer who desires to self-perform the work of a contract must demonstrate good faith efforts if the goal has not been met. Sub-Contractors were not prohibited from submitting bids/proposals and were solicited on work typically self-performed by the prime. Qualifying Remarks:
- (7) Segmented portions of the work to be performed by WMBE/SLBEs in order to increase the likelihood that the goals will be met. This includes, where appropriate, breaking out contract work items into economically feasible units (quantities/scale) to facilitate WMBE/SLBE participation, even when the Bidder/Proposer might otherwise prefer to perform these work items with its own forces. Sub-Contractors were allowed to bid on their own choice of work or trade without restriction to a pre-determined portion. Sub-Contractors were not prohibited from submitting bids/proposals and were solicited on work typically self-performed by the prime. See enclosed comments. Qualifying Remarks:
- (8) Made efforts to assist interested WMBE/SLBEs in obtaining bonding, lines of credit, or insurance as required by the city or contractor. See enclosed documentation on initiatives undertaken and methods to accomplish. Qualifying Remarks:
- (9) Made efforts to assist interested WMBE/SLBEs in obtaining necessary equipment, supplies, materials, or related assistance or services, including participation in an acceptable mentor-protégé program. See enclosed documentation of initiatives and/or agreements. Qualifying Remarks:
- (10) Effectively used the services of the City and other organizations that provide assistance in the recruitment and placement of WMBE/SLBEs. See enclosed documentation. The following services were used:

Note: Provide any unsolicited information that will support the Bid/RFP Compliance Evaluation. Named Documents Are:



Participation Plan: Guidance for Complying with Good Faith Efforts Outreach
(page 2 of 2)

1. All firms on the WMBE/SLBE Goal Setting List must be solicited and documentation provided for email, fax, letters, phone calls, and other methods of outreach/communication with the listed firms. The DMI Solicited and DMI-Utilized forms must be completed for all firms solicited or utilized. Other opportunities for subcontracting may be explored by consulting the City of Tampa MBD Office and/or researching the on-line Diversity Management Business System Directory for Tampa certified WMBE/SLBE firms.
2. Solicitation of WMBE/SLBEs, via written or electronic notification, should provide specific information on the services needed, where plans can be reviewed and assistance offered in obtaining these, if required. Solicitations should be sent a minimum of a week (i.e. 5 business days or more) before the bid/proposal date. Actual copies of the bidder's solicitation containing their scope specific instructions should be provided.
3. With any quotes received, a follow-up should be made when needed to confirm detail scope of work. For any WMBE/SLBE low quotes rejected, an explanation shall be provided detailing negotiation efforts.
4. If a low bid WMBE/SLBE is rejected or deemed unqualified the contractor must provide an explanation and supporting documentation for this decision.
5. Prime shall break down portions of work into economical feasible opportunities for subcontracting. The WMBE/SLBE directory may be useful in identifying additional subcontracting opportunities and firms not listed in the "WMBE/SLBE Goal Setting Firms List."
6. Contractor shall not preclude WMBE/SLBEs from bidding on any part of work, even if the Contractor may desire to self-perform the work.
7. Contractor shall avoid relying solely on subcontracting out work-scope where WMBE/SLBE availability is not sufficient to attain the pre-determined subcontract goal set for the Bid or when targeted sub-consultant participation is stated within the RFP/RFQ.
8. In its solicitations, the Bidder should offer assistance to WMBE/SLBEs in obtaining bonding, insurance, et cetera, if required of subcontractors by the City or Prime Contractor.
9. In its solicitation, the Bidder should offer assistance in obtaining equipment for a specific job to WMBE/SLBEs, if needed.
10. Contractor should use the services offered by such agencies as the City of Tampa Minority and Small Business Development Office, Hillsborough County Entrepreneur Collaborative Center, Hillsborough County Economic Development Department's MBE/SBE Program and the NAACP Empowerment Center to name a few for the recruitment and placement of WMBEs/SLBEs.



Failure to Complete, Sign and Submit Both Forms 10 & 20 SHALL render the Bid or Proposal Non-Responsive

**Page 1 of 4 – DMI Solicited/Utilized Schedules
 City of Tampa – Schedule of **All Solicited** Sub-(Contractors/Consultants/Suppliers)
 (FORM MBD-10)**

Contract No.: _____ Contract Name: _____
 Company Name: _____ Address: _____
 Federal ID: _____ Phone: _____ Fax: _____ Email: _____

Check applicable box(es). Detailed Instructions for completing this form are on page 2 of 4.

- No Firms were contacted or solicited for this contract.
- No Firms were contacted because: _____
- See attached list of additional Firms solicited and all supplemental information (List must comply to this form)
Note: Form MBD-10 must list ALL subcontractors solicited including Non-minority/small businesses

NIGP Code Categories: Buildings = 909, General = 912, Heavy = 913, Trades = 914, Architects = 906, Engineers & Surveyors = 925, Supplier = 912-77

S = SLBE W=WMBE O = Neither	Company Name Address Phone, Fax, Email	Type of Ownership (F=Female M=Male) BF BM = African Am. HF HM = Hispanic AF AM = Asian Am. NF NM = Native Am. CF CM = Caucasian	Trade or Services NIGP Code (listed above)	Contact Method L=Letter F=Fax E=Email P=Phone	Quote or Response Received Y/N

Failure to Complete, Sign and Submit
 this form with your Bid or Proposal
 Shall render the Bid N -

It is hereby certified that the information provided is an accurate and true account of contacts and solicitations for sub-contracting opportunities on this contract.

Signed: _____ Name/Title: _____ Date: _____

**Failure to Complete, Sign and Submit Both Forms 10 & 20 SHALL render the Bid or Proposal Non-Responsive
 Forms must be included with Bid / Proposal**



Instructions for completing The Sub-(Contractors/Consultants/ Suppliers) Solicited Form (Form MBD-10)

This form must be submitted with all bids or proposals. All subcontractors (regardless of ownership or size) solicited and subcontractors from whom unsolicited quotations were received must be included on this form. The instructions that follow correspond to the headings on the form required to be completed. Note: Ability or desire to self-perform all work shall not exempt the prime from Good Faith Efforts to achieve participation.

- **Contract No.** This is the number assigned by the City of Tampa for the bid or proposal.
- **Contract Name.** This is the name of the contract assigned by the City of Tampa for the bid or proposal.
- **Contractor Name.** The name of your business and/or doing business as (dba) if applicable.
- **Address.** The physical address of your business.
- **Federal ID. FIN.** A number assigned to your business for tax reporting purposes.
- **Phone.** Telephone number to contact business.
- **Fax.** Fax number for business.
- **Email.** Provide email address for electronic correspondence.
- **No Firms were contacted or solicited for this contract.** Checking the box indicates that a pre-determined Subcontract Goal or Participation Plan Requirement was not set by the City resulting in your business not using subcontractors and will self-perform all work. If during the performance of the contract you employ subcontractors, the City must pre-approve subcontractors. Use of the “Sub-(Contractors/Consultants/Suppliers) Payments” form (MBD Form-30) must be submitted with every pay application and invoice. Note: Certified **SLBE or WMBE firms** bidding as Primes **are not exempt** from outreach and solicitation of subcontractors.
- **No Firms were contacted because.** Provide brief explanation why no firms were contacted or solicited.
- **See attached documents.** Check box, if after you have completed the DMI Form in its entirety, you need more space to list additional firms and/or if you have supplemental information/documentation relating to the form. All DMI data not submitted on the MBD Form-10 must be in the same format and have all requested data from MBD Form-10 included.

The following instructions are for information of any and all subcontractors solicited.

- **“S” = SLBE, “W” = WMBE.** Enter “S” for firms Certified by the City as Small Local Business Enterprises and/or “W” for firms Certified by the City as either Women/Minority Business Enterprise; **“O” = Non-certified others.**
- **Federal ID. FIN.** A number assigned to a business for tax reporting purposes. This information is critical in proper identification and payment of the contractor/subcontractor.
- **Company Name, Address, Phone & Fax.** Provide company information for verification of payments.
- **Type of Ownership.** Indicate the Ethnicity and Gender of the owner of the subcontracting business.
- **Trade, Services, or Materials** indicate the trade, service, or materials provided by the subcontractor. NIGP codes aka “National Institute of Governmental Purchasing” are listed at top section of document.
- **Contact Method L=letter, F=fax, E=Email, P=Phone.** Indicate with letter the method(s) of soliciting for bid.
- **Quote or Resp. (response) Rec’d (received) Y/N.** Indicate “Y” Yes if you received a quotation or if you received a response to your solicitation. Indicate “N” No if you received no response to your solicitation from the subcontractor. Must keep records: log, ledger, documentation, etc. that can validate/verify.

If additional information is required or you have questions, please contact the Equal Business Opportunity Program - Minority and Small Business Development Office at (813) 274-5522.



Failure to Complete, Sign and Submit Both Forms 10 & 20 SHALL render the Bid or Proposal Non-Responsive

Page 3 of 4 – DMI Solicited/Utilized Schedules
City of Tampa – Schedule of All To-Be-Utilized Sub-(Contractors/Consultants/Suppliers)
(FORM MBD-20)

Contract No.: _____ Contract Name: _____
Company Name: _____ Address: _____
Federal ID: _____ Phone: _____ Fax: _____ Email: _____

Check applicable box(es). Detailed Instructions for completing this form are on page 4 of 4.

See attached list of additional Firms Utilized and all supplemental information (List must comply to this form)

Note: Form MBD-20 must list ALL subcontractors To-Be-Utilized including Non-minority/small businesses

No Subcontracting/consulting (of any kind) will be performed on this contract.

No Firms are listed to be utilized because: _____

NIGP Code General Categories: Buildings = 909, General = 912, Heavy = 913, Trades = 914, Architects = 906, Engineers & Surveyors = 925, Supplier = 912-77

Enter "S" for firms Certified as Small Local Business Enterprises, "W" for firms Certified as Women/Minority Business Enterprise, "O" for Other Non-Certified

S = SLBE W=WMBE O =Neither	Company Name Address Phone, Fax, Email	Type of Ownership (F=Female M=Male) BF BM = African Am. HF HM = Hispanic Am. AF AM = Asian Am. NF NM = Native Am. CF CM = Caucasian	Trade, Services, or Materials NIGP Code Listed above	\$ Amount of Quote. Letter of Intent (LOI) if available	Percent of Scope or Contract %

Failure to Complete, Sign and Submit
this form with your Bid or Proposal
Shall render the Bid Non-Responsive

Total ALL Subcontract / Supplier Utilization \$ _____
Total SLBE Utilization \$ _____
Total WMBE Utilization \$ _____
Percent SLBE Utilization of Total Bid/Proposal Amt. _____% Percent WMBE Utilization of Total Bid/Proposal Amt. _____%

It is hereby certified that the following information is a true and accurate account of utilization for sub-contracting opportunities on this Contract.

Signed: _____ Name/Title: _____ Date: _____

Failure to Complete, Sign and Submit Both Forms 10 & 20 SHALL render the Bid or Proposal Non-Responsive
Forms must be included with Bid / Proposal



Page 4 of 4 DMI – Solicited/**Utilized**

Instructions for completing **The Sub-(Contractors/Consultants/ Suppliers) to be Utilized Form (Form MBD-20)**

This form must be submitted with all bids or proposals. All subcontractors (regardless of ownership or size) projected to be utilized must be included on this form. Note: Ability or desire to self-perform all work shall not exempt the prime from Good Faith Efforts to achieve participation.

Contract No. This is the number assigned by the City of Tampa for the bid or proposal.

- **Contract Name.** This is the name of the contract assigned by the City of Tampa for the bid or proposal.
- **Contractor Name.** The name of your business and/or doing business as (dba) if applicable.
- **Address.** The physical address of your business.
- **Federal ID.** FIN. A number assigned to your business for tax reporting purposes.
- **Phone.** Telephone number to contact business.
- **Fax.** Fax number for business.
- **Email.** Provide email address for electronic correspondence.
- **No Subcontracting/consulting (of any kind) will be performed on this contract.** Checking box indicates your business will not use subcontractors when no Subcontract Goal or Participation Plan Requirement was set by the City, but will self-perform all work. When subcontractors are utilized during the performance of the contract, the “Sub-(Contractors/Consultants/Suppliers) Payments” form (MBD Form-30) must be submitted with every pay application and invoice. Note: certified **SLBE or WMBE firms** bidding as Primes **are not exempt** from outreach and solicitation of subcontractors, including completion and submitting Form-10 and Form-20.
- **No Firms listed To-Be-Utilized.** Check box; provide brief explanation why no firms were retained when a goal or participation plan requirement was set on the contract. Note: mandatory compliance with Good Faith Effort outreach (GFECF) requirements applies (MBD Form-50) and supporting documentation must accompany the bid.
- **See attached documents.** Check box, if after completing the DMI Form in its entirety, you need more space to list additional firms and/or if you have supplemental information/documentation relating to the scope/value/percent utilization of subcontractors. Reproduce copies of MBD-20 and attach. All data not submitted on duplicate forms must be in the same format and content as specified in these instructions.

The following instructions are for information of Any and All subcontractors To Be Utilized.

- **Federal ID.** FIN. A number assigned to a business for tax reporting purposes. This information is critical in proper identification of the subcontractor.
- **“S” = SLBE, “W” = WMBE.** Enter “S” for firms Certified by the City as Small Local Business Enterprises and/or “W” for firms Certified by the City as Women/Minority Business Enterprise; **“O” = Non-certified others.**
- **Company Name, Address, Phone & Fax.** Provide company information for verification of payments.
- **Type of Ownership.** Indicate the Ethnicity and Gender of the owner of the subcontracting business.
- **Trade, Services, or Materials (NIGP code if Known)** Indicate the trade, service, or material provided by the subcontractor. Abbreviated list of NIGP is available at <http://www.tampagov.net/mbd> “Information Resources”.
- **Amount of Quote, Letters of Intent** (required for both SLBEs and WMBEs).
- **Percent of Work/Contract.** Indicate the percent of the total contract price the subcontract(s) represent. For CCNA only (i.e. Consultant A/E Services) you must indicate subcontracts as percent of total scope/contract.
- **Total Subcontract/Supplier Utilization.** – Provide total dollar amount of all subcontractors/suppliers projected to be used for the contract. (Dollar amounts may be optional in CCNA depending on solicitation format).
- **Total SLBE Utilization.** Provide total dollar amount for all projected SLBE subcontractors/Suppliers used for this contract. (Dollar amounts may be optional in CCNA proposals depending on the solicitation format).
- **Total WMBE Utilization.** Provide total dollar amount for all projected WMBE subcontractors/Suppliers used for this contract. (Dollar amounts may be optional in CCNA proposals depending on the solicitation format).
- **Percent SLBE Utilization.** Total amount allocated to SLBEs divided by the total bid/proposal amount.
- **Percent WMBE Utilization.** Total amount allocated to WMBEs divided by the total bid/proposal amount.

If additional information is required or you have questions, please contact the Equal Business Opportunity Program - Minority and Small Business Development Office at (813) 274-5522.

TAMPA BID BOND
Contract 22-C-00022; Citywide Roadway Improvements and Street Resurfacing

KNOW ALL MEN BY THESE PRESENTS, that we, _____

(hereinafter called the Principal) and _____

(hereinafter called the Surety) a Corporation chartered and existing under the laws of the State of _____, with its principal offices in the City of _____, and authorized to do business in the State of Florida, are held and firmly bound unto the City of Tampa, a Municipal Corporation of Hillsborough County, Florida, in the full and just sum of 5% of the amount of the (Bid) (Proposal) good and lawful money of the United States of America, to be paid upon demand of the City of Tampa, Florida, to which payment will and truly to be made we bind ourselves, our heirs, executors, administrators, successors, and assigns, jointly and severally and firmly these presents.

WHEREAS, the Principal is about to submit, or has submitted to the City of Tampa, Florida, a Proposal for the construction of certain facilities for the City designated Contract 22-C-00022, Citywide Roadway Improvements and Street Resurfacing.

WHEREAS, the Principal desires to file this Bond in accordance with law, in lieu of a certified Bidder's check otherwise required to accompany this Proposal.

NOW, THEREFORE: The conditions of this obligation are such that if the Proposal be accepted, the Principal shall, within twenty (20) days after the date of receipt of written Notice of Award, execute a contract in accordance with the Proposal and upon the terms, conditions and price set forth therein, in the form and manner required by the City of Tampa, Florida and execute a sufficient and satisfactory Public Construction Bond payable to the City of Tampa, Florida in an amount of one hundred percent (100%) of the total contract price, in form and with security satisfactory to said City, then this Bid Bond obligation is to be void; otherwise to be and remain in full force and virtue in law, and the Surety shall, upon failure of the Principal to comply with any or all of the foregoing requirements within the time specified above, immediately pay to the aforesaid City, upon demand, the amount thereof, in good and lawful money of the United States of America, not as a penalty, but as liquidated damages.

IN TESTIMONY THEREOF, the Principal and Surety have caused these presents to be duly signed and sealed this _____ day of _____, 20____.

Principal

BY _____

TITLE _____

BY _____

TITLE _____

(SEAL)

Producing Agent

Producing Agent's Address

Name of Agency

The addition of such phrases as "not to exceed" or like import shall render the (Bid) (Proposal) non-responsive.

AGREEMENT

For furnishing all labor, materials and equipment, together with all work incidental thereto, necessary and required for the performance of the work for the construction of Contract 22-C-00022 in accordance with your Proposal dated _____, amounting to a total of \$ _____ as completed in accordance with subsections I-2.09 and I-2.10 of the Instruction to Bidders.

This AGREEMENT, made and entered into in triplicate, between the City of Tampa, Florida, hereinafter called the City, and _____ hereinafter called the Contractor, as of the _____ day of _____, 20__ when the City Council of the City of Tampa, Florida adopted a Resolution authorizing, among other things, the Mayor's execution of this Agreement.

WITNESSETH that, in consideration of the mutual stipulations, agreements, and covenants herein contained, the parties hereto have agreed and hereby agree with each other, the Party of the First Part for itself, its successors and assigns, and the Party of the Second Part for itself, or himself, or themselves, and its successors and assigns, or his or their executors, administrators and assigns, as follows:

Contract 22-C-00022; Citywide Roadway Improvements and Street Resurfacing, shall include, but not be limited to, construction of various intersection and roadway-related improvements including the installation of traffic signals, roadway widening, drainage improvements with all associated work required for a complete project in accordance with the Contract Documents.

Contract Documents referred to in Article 1.01 of this Agreement also includes this volume, applicable standard drawings, the plans and any provisions referred to whether actually attached or not.

TAMPA AGREEMENT

SECTION 1 GENERAL

ARTICLE 1.01 THE CONTRACT

Except for titles, subtitles, headings, running headlines, and tables of contents (all of which are printed herein merely for convenience), the following, except for such portions thereof as may be specifically excluded, constitute the Contract:

The Notice to Bidders;
The Instructions to Bidders, including Special Instructions and General Instructions;
The Proposal;
The Bid Bond;
The Certification of Nonsegregated Facilities;
The Notice of Award;
The Agreement;
The Performance Bond;
The Notice To Proceed;
The Specifications, including the General Provisions, the Workmanship and Materials, the Specific Provisions or the Contract Items
The Plans;
All Supplementary Drawings Issued after award of the Contract;
All Addenda issued by the City prior to the receipt of proposals;
All provisions required by law to be inserted in this Contract, whether actually inserted or not.

ARTICLE 1.02 DEFINITIONS

The following words and terms, or pronouns used in their stead, shall, wherever they appear in this Contract, be construed as follows, unless different meaning is clear from the context:

(a)"City" shall mean the City of Tampa, Florida, represented by its Mayor and City Council, Party of the First Part, or such other City official as shall be duly empowered to act for the City on matters relating to this Contract.

(b)"Contractor" shall mean the Party of the Second Part hereto, whether corporation, firm or individual, or any combination thereof, and its, their, or his successors, personal representatives, executors, administrators, and assigns, and any person, firm or corporation who or which shall at any time be substituted in the place of the Party of the Second Part under this Contract.

(c)"Engineer" shall mean the Director of the Department or his duly authorized representative.

(d)"Consultant" shall mean the engineering or architectural firm or individual employed by the City to consult with and advise the City in the construction of the project.

(e)"Surety" shall mean any person, firm or corporation that has executed as Surety the Contractor's Performance Bond securing the performance of this Contract.

(f)"The Work" shall mean everything expressly or implied required to be furnished and done by the Contractor under the Contract, and shall include both Contract Work

and Extra Work.

(g)"Contract Work" shall mean everything expressly or implied required to be furnished and done by the Contractor by any one or more of the Contract parts referred to in Article 1.01 hereof, except Extra Work, as hereinafter defined; it being understood that, in case of any inconsistency in or between any part or parts of this Contract, the Engineer shall determine which shall prevail.

(h)"Contract" or "Contract Documents" shall mean each of the various part of the Contract referred to in Article 1.01 hereof, both as a whole and severally.

(i)"Extra Work" shall mean work other than that required either expressly or implied by the contract in its present form.

(j)"Plans" shall mean only those drawings specifically referred to as such in these documents, or in any Addendum. Drawings issued after the execution of the Contract to explain further, or to illustrate, or to show changes in the work, will be known as "Supplementary Drawings" and shall be binding upon the Contractor with the same force as the Plans.

(k)"Specifications" shall mean all of the directions, requirements, and standards of performance applying to the work, as hereinafter detailed and designated as such, or which may be issued in an addendum.

(l)"Addendum or Addenda" shall mean the additional contract provisions issued in writing prior to the receipt of bids.

(m)"Notice" shall mean written notice. Notice shall be served upon the Contractor, either personally or by leaving the said notice at his residence or with any employee found on the work, or addressed to the Contractor at the residence or place of business given in his proposal and deposited in a postpaid wrapper in any post office box regularly maintained by the United States Post Office.

(n)"Project" shall mean the entire improvement package or related work. The "project" may consist of several different, but related, contracts.

(o)"Site" shall mean, and be limited to, the area upon or in which the Contractor's operations are carried on and such other appropriate areas as may be designed as such by the Engineer.

(p)"Subcontractor" shall mean any person, firm, or corporation, other than employees of the Contractor, who or which contracts with the Contractor to furnish, or actually furnishes labor, or labor and materials, or labor and equipment or labor, materials, and equipment at the site.

(q)Whenever in the Contract the words "directed", "required", "permitted", "ordered", "designated", "prescribed", and words of like import are used, they shall imply the direction, requirement, permission, order, designation, or prescription of the Engineer; and "approved", "acceptable", "satisfactory", "in the judgement of", and words of like import shall mean approved by, or acceptable to, or satisfactory to, or in the judgment of the Engineer.

(r)Whenever in the Contract the word "day" is used, it shall mean calendar day.

(s)"Final Acceptance" shall mean acceptance of the

work as evidenced by an official resolution of the City. Such acceptance shall be deemed to have taken place only if and when an approving resolution has been adopted by the City Council. The final acceptance shall be signed only after the City has assured itself by tests, inspection, or otherwise, that all of the provisions of the Contract have been carried out to its satisfaction.

(t)"Eastern Standard Time" shall be construed as the time being observed in the City on the day proposals are received or other documents issued or signed.

SECTION 2 POWERS OF THE CITY'S REPRESENTATIVES

ARTICLE 2.01 THE ENGINEER

It is covenanted and agreed that the Engineer, in addition to those matters elsewhere herein expressly made subject to his determination, direction, or approval, shall have the power, subject to such express provisions and limitations herein contained as are not in conflict herewith, and subject to review by the Mayor and City Council:

(a)To monitor the performance of the work.

(b)To determine the amount, kind, quality, sequence, and location of the work to be paid for hereunder and, when completed, to measure such work for payment.

(c)To determine all questions of an engineering character in relation to the work, to interpret the Plans, Specifications and Addenda.

(d)To determine how the work of this Contract shall be coordinated with the work of other contractors engaged simultaneously on this project.

(e)To make minor changes in the work as he deems necessary, provided such changes do not result in a net increase in the cost to the City or to the Contractor of the work to be done under the Contract.

(f)To amplify the Plans, add explanatory information and furnish additional Specifications and Drawings consistent with the intent of the Contract Documents.

The power of the Engineer shall not be limited to the foregoing enumeration, for it is the intent of this Contract that all of the work shall be subject to his determinations and approval, except where the determination or approval of someone other than the Engineer is expressly called for herein and except as subject to review by the Mayor and City Council. All orders of the Engineer requiring the Contractor to perform work as Contract work shall be promptly obeyed by the Contractor.

The Engineer shall not, however, have the power to issue an extra work order, and the performance of such work on the order of the Engineer without previously obtaining written confirmation thereof from the Mayor in accordance with Article 7.02 hereof may constitute a waiver of any right to extra compensation therefor. The Contractor is warned that the Engineer has no power to change the terms and provisions of this Contract, except minor changes where such change results in no net increase in the Contract Price.

ARTICLE 2.02 DIRECTOR

The Director of the Department in addition to those matters

expressly made subject to his determination, direction or approval in his capacity as "Engineer", shall also have the power:

(a)To review any and all questions in relation to this Contract and its performance, except as herein otherwise specifically provided, and his determination upon such review shall be final and conclusive upon the Contractor.

(b)With the approval of the Mayor and City Council to authorize modifications or changes in the Contract so as to require: (1) the performance of extra work, or (2) the omission of Contract work whenever he deems it in the interest of the City to do so, or both.

(c)To suspend the whole or any part of the work whenever, in his judgment, such suspension is required: (1) in the interest of the City generally, or (2) to coordinate the work of the various Contractors engaged on this project, or (3) to expedite the completion of the entire project, even though the completion of this particular Contract may be thereby delayed, without compensation to the Contractor for such suspension other than extending the time for the completion of the work, as much as it may have been, in the opinion of the City, delayed by such a suspension.

(d)If, before the final acceptance of all the work contemplated herein, it shall be deemed necessary to take over, use, occupy, or operate any part of the completed or partly completed work, the Engineer shall have the right to do so and the Contractor will not, in any way, interfere with or object to the use, occupation, or operation of such work by the City after receipt of notice in writing from the Engineer that such work or part thereof will be used by the City on and after the date specified in such notice. Such taking over, use, occupancy or operation of any part of the completed or partially completed work shall not constitute final acceptance or approval of any such part of the work.

ARTICLE 2.03 NO ESTOPPEL

The City shall not, nor shall any department, officer, agent, or employee thereof, be bound, precluded, or estopped by any determination, decision, acceptance, return, certificate, or payment made or given under or in connection with this Contract by any officer, agent or employee of the City at any time either before or after final completion and acceptance of the work and payment therefor: (a) from showing the true and correct classification, amount, quality, or character of the work done, or that any determination, decision, acceptance, return certificate or payment is untrue, incorrect or improperly made in any particular, or that the work or any part thereof does not in fact conform to the requirements of the Contract Documents, and (b) from demanding and recovering from the Contractor any overpayments made to him or such damages as it may sustain by reason his failure to comply with the requirements of the Contract of Documents, or both.

ARTICLE 2.04 NO WAIVER OF RIGHTS

Neither the inspection, nor any order, measurements or certificate of the City or its employees, officers, or agents, nor by any order of the City for payment of money, nor any money, nor payments for or acceptance of the whole or any part of the work by the City, nor any extension of time, nor any changes in the Contract, Specifications or Plans, nor any possession by the City or its employees shall operate as a

waiver of any provisions of this Contract, nor any power herein provided nor shall any waiver of any breach of this Contract be held as a waiver of any other subsequent breach.

Any remedy provided in this Contract shall be taken and construed as cumulative, namely, in addition to each and every other suit, action, or legal proceeding. The City shall be entitled as of right to an injunction against any breach of the provisions of this Contract.

SECTION 3 PERFORMANCE OF WORK

ARTICLE 3.01 CONTRACTOR'S RESPONSIBILITY

The Contractor shall do all the work and furnish, at his own cost and expense, all labor, materials, equipment, and other facilities, except as herein otherwise provided, as may be necessary and proper for performing and completing the work under this Contract. The Contractor shall be responsible for the entire work until completed and finally accepted by the City.

The work shall be performed in accordance with the true intent and meaning of the Contract Documents. Unless otherwise expressly provided, the work must be performed in accordance with the best modern practice, with materials as specified and workmanship of the highest quality, all as determined by and entirely to the satisfaction of the Engineer.

Unless otherwise expressly provided, the means and methods of construction shall be such as the Contractor may choose, subject, however, to the approval of the Engineer. Only adequate and safe procedure, methods, structures and equipment shall be used. The Engineer's approval or the Engineer's failure to exercise his right thereon shall not relieve the Contractor of obligations to accomplish the result intended by the Contract, nor shall such create a cause of action for damages.

ARTICLE 3.02 COMPLIANCE WITH LAWS

The Contractor must comply with all local, State and Federal laws, rules, ordinances and regulations applicable to this Contract and to the work done hereunder, and must obtain, at his own expense, all permits, licenses or other authorization necessary for the prosecution of the work.

No work shall be performed under this Contract on Sundays, legal holidays or after regular working hours without the express permission of the Engineer. Where such permission is granted, the Engineer may require that such work be performed without additional expense to the City.

ARTICLE 3.03 INSPECTION

During the progress of the work and up to the date of final acceptance, the Contractor shall, at all times, afford the representatives of the City, the Florida Department of Environmental Regulation, and if applicable, the Federal Environmental Protection Agency and the Federal Department of Labor every reasonable, safe and proper facility for inspecting the work done or being done at the

site. The inspection of any work shall not relieve the Contractor of any of his obligations to perform proper and satisfactory work as herein specified. Finished or unfinished work found not to be in strict accordance with the Contract shall be replaced as directed by the Engineer, even though such work may have been previously approved and payment made therefor.

The City shall have the right to reject materials and workmanship which are defective or require their correction. Rejected work and materials must be promptly removed from the site, which must at all times be kept in a reasonably clean and neat condition.

Failure or neglect on the part of the City to condemn or reject bad or inferior work or materials shall not be construed to imply an acceptance of such work or materials, if it becomes evident at any time prior to the final acceptance of the work by the City. Neither shall it be construed as barring the City at any subsequent time from the recovery of damages of such a sum of money as may be needed to build anew all portions of the work in which inferior work or improper materials were used, wherever found.

Should it be considered necessary or advisable by the City at any time before final acceptance of the entire work to make examinations of work already completed, by removing or tearing out all or portions of such work, the Contractor shall, on request, promptly furnish all necessary facilities, labor, and material for that purpose. If such work is found to be defective in any material respect, due to the fault of the Contractor or his subcontractors, he shall defray all expenses of such examination and of satisfactory reconstruction. If, however, such work is found to meet the requirements of the Contract, the cost of examination and restoration of the work shall be considered an item of extra work to be paid for in accordance with the provisions of Article 7.02 hereof.

ARTICLE 3.04 PROTECTION

During performance and until final acceptance, the Contractor shall be under an absolute obligation to protect the finished and unfinished work against any damage, loss, or injury. The Contractor shall take proper precaution to protect the finished work from loss or damage, pending completion and the final acceptance of all the work included in the entire Contract, provided that such precaution shall not relieve the Contractor from any and all liability and responsibility for loss or damage to the work occurring before final acceptance by the City. Such loss or damage shall be at the risk of and borne by the Contractor, whether arising from acts or omissions of the Contractor or others. In the event of any such loss or damage, the Contractor shall forthwith repair, replace, and make good the work without extension of time therefor, except as may be otherwise provided herein.

The provisions of this Article shall not be deemed to create any new right of action in favor of third parties against the Contractor or the City.

ARTICLE 3.05 PRESERVATION OF PROPERTY

The Contractor shall preserve from damage all property along the line of the work, or which is in the vicinity of or is in anywise affected by the work, the removal or destruction of which is not called for by the Plans. This applies, but is not limited, to the public utilities, trees, lawn areas, building monuments, fences, pipe and underground structures, public streets (except natural wear and tear of streets resulting from legitimate use thereof by the Contractor), and wherever such property is damaged due to the activities of the Contractor, it shall be immediately restored to its original condition by the Contractor and at his own expense.

In case of failure on the part of the Contractor to restore such property, or make good such damage or injury, the City may, upon forty-eight (48) hour written notice, proceed to repair, rebuild, or otherwise restore such property as may be deemed necessary, and the cost thereof will be deducted from any monies due or which may become due the Contractor under this Contract. Nothing in this clause shall prevent the Contractor from receiving proper compensation for the removal, damage, or replacement of any public or private property not shown on the Plans, when this is made necessary by alteration of grade or alignment authorized by the Engineer, provided that such property has not been damaged through fault of the Contractor, his employees or agents.

ARTICLE 3.06 BOUNDARIES

The Contractor shall confine his equipment, apparatus, the storage of materials, supplies and apparatus of his workmen to the limits indicated on the plans, by law, ordinances, permits or direction of the Engineer.

ARTICLE 3.07 SAFETY AND HEALTH REGULATIONS

The Contractor shall comply with the Department of Labor Safety and Health Regulations for construction promulgated under the Occupational Safety and Health Act of 1970 (PL 91- 596) and under Section 107 of the Contract Work Hours and Safety Standards Act (PL91-54).

ARTICLE 3.08 TAXES

All taxes of any kind and character payable on account of the work done and materials furnished under this Contract shall be paid by the Contractor and shall be deemed to have been included in his bid. The laws of the State of Florida provide that sales and use taxes are payable by the Contractor upon the tangible personal property incorporated in the work and such taxes shall be paid by the Contractor and shall be deemed to have been included in his bid.

ARTICLE 3.09 ENVIRONMENTAL CONSIDERATIONS

The Contractor, in the performance of the work under this Contract, shall comply with all Local, State and Federal laws, statutes, ordinances, rules and regulations applicable to protection of the environment; and, in the event he violates any of the provisions of same, he shall be answerable to the Local, State and Federal agencies designated by law to protect the environment. In the event the City receives, from any of the environmental agencies, a citation which is occasioned by an act or omission of the Contractor or his

subcontractor or any officers, employees or agents of either, it is understood and agreed that the Contractor shall automatically become a party-respondent under said citation; and the City immediately shall notify the Contractor and provide him with a copy of said citation.

The Contractor shall comply with the requirements of the citation and correct the offending condition(s) within the time stated in said citation and further shall be held fully responsible for all fines and/or penalties.

**SECTION 4
TIME PROVISIONS**

ARTICLE 4.01 TIME OF START AND COMPLETION

The Contractor must commence work within thirty (30) days subsequent to the date of the receipt of the "Notice to Proceed" by the City unless otherwise provided in the Specific Provisions and Special Instructions. Time being of the essence of this Contract, the Contractor shall thereafter prosecute the work diligently, using such means and methods of construction as well as secure its full completion in accordance with the requirements of the Contract Documents no later than the date specified therefor, or on the date to which the time for completion may be extended.

The Contractor must complete the work covered by this Contract in the number of consecutive calendar days set forth in the Instructions to Bidders, unless the date of completion is extended pursuant to the provisions of Article 4.05 hereof.

The period for performance shall start from the date of signing of this Agreement by the City.

The actual date of completion will be established after a final inspection as provided in Article 4.07 hereof.

ARTICLE 4.02 PROGRESS SCHEDULE

To enable the work to be laid out and prosecuted in an orderly and expeditious manner, the Contractor shall submit to the Engineer a proposed progress schedule within fifteen (15) days after the award of this Contract.

The schedule shall state the Contract starting date, time for completion and date of completion and shall show the anticipated time of starting and completion of each of the various operations to be performed under this Contract, together with all necessary and appropriate information regarding sequence and correlation of work and an estimated time required for the delivery of all materials and equipment required for the work. The proposed schedule shall be revised as directed by the Engineer until finally approved by him, and, after such approval, shall be strictly adhered to by the Contractor. The approved progress schedule may be changed only with the written permission of the Engineer.

If the Contractor shall fail to adhere to the approved progress schedule or the schedule as revised, he shall promptly adopt such other or additional means and methods of construction as will make up for the time lost, and will assure completion in accordance with the contract time.

ARTICLE 4.03 APPROVAL REQUESTS

From time to time, as the work progresses and in the sequence indicated by the approved schedule, the Contractor must submit to the Engineer a specific request, in writing, for each item of information or approval required of him by the Contract. These requests must be submitted sufficiently in advance of the date upon which the information or approval is actually required by the Contractor to allow for the time the Engineer may take to act upon such submissions or resubmissions. The Contractor shall not have any right to an extension of time on account of delays due to his failure to submit his requests for the required information or the required approval in accordance with these requirements.

ARTICLE 4.04 COORDINATION WITH OTHER CONTRACTORS

During progress of the work, other Contractors may be engaged in performing other work on this project or on other projects on the site. In that event, the Contractor shall coordinate the work to be done hereunder with the work of such other Contractors in such manner as the Engineer may direct.

ARTICLE 4.05 EXTENSION OF TIME

If such an application is made, the Contractor shall be entitled to an extension of time for delay in completion of the work should the Contractor be obstructed or delayed in the commencement, prosecution or completion of any part of said work by any act or delay of the City, or by acts or omissions of other Contractors on this project, or by a riot, insurrection, war, pestilence, acts of public authorities, fire, lightning, hurricanes, earthquakes, tornadoes, floods, extremely abnormal and excessive inclement weather as indicated by the records of the local weather bureau for a five-year period preceding the date of the Contract, or by strikes, or other causes, which causes of delay mentioned in this Article, in the opinion of the City, are entirely beyond the expectation and control of the Contractor.

The Contractor shall, however, be entitled to an extension of time for such causes only for the number of days of delay which the City may determine to be due solely to such causes and only to the extent that such occurrences actually delay the completion of the project and then only if the Contractor shall have strictly complied with all of the requirements of Articles 4.01, 4.02, 4.03 and 4.04 hereof. It is hereby understood that the determination by the Engineer as to the order and sequence of the work shall not in itself constitute a basis for extension of time.

The determination made by the City on an application for an extension of time shall be binding and conclusive on the Contractor.

Delays caused by failure of the Contractor's materialmen, manufacturers, and dealers to furnish approved working drawings, materials, fixtures, equipment, appliances, or other fittings on time or failure of subcontractors to perform their work shall not constitute a basis of extension of time.

The Contractor agrees to make no claim for damages for delay in the performance of this Contract occasioned by any

act or omission to act of the City or any of its representatives or because of any injunction which may be brought against the City or its representatives and agrees that any such claim shall be fully compensated for by an extension of time to complete performance of the work as provided herein.

ARTICLE 4.06 LIQUIDATED DAMAGES

It is mutually agreed between the parties that time is the essence of this Contract and that there will be on the part of the City considerable monetary damage in the event the Contractor should fail to complete the work within the time fixed for completion in the Contract or within the time to which such completion may have been extended.

The amount per day set forth in the Instructions to Bidders is hereby agreed upon as the liquidated damages for each and every calendar day that the time consumed in completing the work under this Contract exceeds the time allowed.

This amount shall, in no event, be considered as a penalty or otherwise than as the liquidated and adjusted damages to the City because of the delay and the Contractor and his Surety agree that the stated sum per day for each such day of delay shall be deducted and retained out of the monies which may become due hereunder and if not so deductible, the Contractor and his Surety shall be liable therefor.

ARTICLE 4.07 FINAL INSPECTION

When the work has been completed in accordance with the requirements of the Contract and final cleaning up performed, a date for final inspection of the work by the Engineer shall be set by the Contractor in a written request therefor, which date shall be not less than ten (10) days after the date of such request. The work will be deemed complete as of the date so set by the Contractor if, upon such inspection, the Engineer determines that no further work remains to be done at the site.

If such inspection reveals interms of work still to be performed, however, the Contractor shall promptly perform them and then request a reinspection. If, upon such inspection, the Engineer determines that the work is complete, the date of final completion shall be deemed to be the last day of such reinspection.

**SECTION 5
SUBCONTRACTS AND ASSIGNMENTS**

ARTICLE 5.01 LIMITATIONS AND CONSENT

The Contractor shall not assign, transfer, convey, sublet or otherwise dispose of this Contract or of his right, title, or interest therein, or his power to execute such Contract, or to assign any monies due or to become due thereunder to any other person, firm or corporation unless the previous written consent of the City shall first be obtained thereto and the giving of any such consent to a particular subcontract or assignment shall not dispense with the necessity of such consent to any further or other assignment.

Before making any subcontract, the Contractor must submit a

written statement to the Engineer, giving the name and address of the proposed contractor, the portion of the work and materials which he is to perform and furnish and any other information tending to prove that the proposed subcontractor has the necessary facilities, skill, integrity, past experience and financial resources to perform the work in accordance with the terms and conditions of this Contract.

If the City finds that the proposed subcontractor is qualified, the Contractor will be notified in writing. The City may revoke approval of any subcontractor when such subcontractor evidences an unwillingness or inability to perform his work in strict accordance with these Contract Documents. Notice of such revocation of approval will be given in writing to the Contractor.

The Contractor will promptly, upon request, file with the City a conformed copy of the subcontract. The Contractor shall cause appropriate provisions to be inserted in all subcontracts relative to the work to bind subcontractors to the Contractor by the terms of these Contract Documents, insofar as applicable to the work of subcontractors, and to give the Contractor the same power as regards terminating any subcontracts that the City may exercise over the Contractor under provisions of these Contract Documents.

The Contractor shall be required to perform with his own forces at least twenty-five (25) percent of the work, unless written consent to subcontract a greater percentage of the work is first obtained from the City.

ARTICLE 5.02 RESPONSIBILITY

The approval by the City of a subcontractor shall not relieve the Contractor of any of his responsibilities, duties, and liabilities hereunder. The Contractor shall be solely responsible to the City for the acts or defaults or omissions of his subcontractor and of such subcontractor's officers, agents, and employees, each of whom shall for all purposes be deemed to be the agent or employee of the Contractor. Nothing contained in the Contract Documents shall create any contractual relationship between any subcontractor and the City.

SECTION 6 SECURITY AND GUARANTY

ARTICLE 6.01 CONTRACT SECURITY

The Contractor shall execute and deliver to the City a Performance Bond on the form as provided herein, in an amount at least equal to one hundred (100) percent of the full Contract price, such Bond to be executed by a surety company acceptable to the City. The surety on such Performance Bond shall be a surety company duly authorized to do business in the State of Florida, and the Bond shall be issued or countersigned by a local resident producing agent of such surety company who is a resident of the State of Florida, regularly commissioned and licensed in said State, and satisfactory evidence of the authority of the person or persons executing such Bond shall be submitted with the Bond. The Performance Bond shall serve as security for the faithful performance of this Contract, including

maintenance and guaranty provisions, and for the payment of all persons performing labor and furnishing materials in connection with the Contract. The premiums on the Performance Bond shall be paid by the Contractor.

If, at any time, the City shall become dissatisfied with any surety or sureties then upon the Performance Bond, or if for any other reason such bond shall cease to be adequate security for the City, the Contractor shall, within five days after notice so to do, substitute an acceptable Bond in such form and sum and signed by such other sureties as may be satisfactory to the City. The premiums on such Bond shall be paid by the Contractor. No further partial payments shall be deemed due or shall be made until the new sureties have qualified.

ARTICLE 6.02 CONTRACTORS INSURANCE

Insurance required shall be as indicated on Special Instructions pages beginning with "INS-1"

ARTICLE 6.03 AGAINST CLAIMS AND LIENS

The City may withhold from the Contractor as much as any approved payments to him as may, in the opinion of the City, be necessary to secure (a) just claims of any persons supplying labor or materials to the Contractor or any of his subcontractors for the work then due and unpaid; (b) loss due to defective work not remedied, or (c) liability, damage, or loss due to injury to persons or damages to the work or property of other contractors, subcontractors, or others, caused by the act or neglect of the Contractor or of any of his subcontractors. The City shall have the right, as agent for the Contractor, to apply any such amounts so withheld in such manner as the City may deem proper to satisfy such claims or to secure such protection. Such application of such money shall be deemed payments for the account of the Contractor.

ARTICLE 6.04 MAINTENANCE AND GUARANTY

The Contractor hereby guarantees all the work furnished under this Contract against any defects in workmanship and materials for a period of one year following the date of final acceptance of the work by the City. Under this guarantee, the Contractor hereby agrees to make good, without delay, at his own expense, any failure of any part of the work due to faulty materials or manufacture, construction, or installation, or the failure of any equipment to perform satisfactorily all the work put upon it within the limits of the Contract Documents, and further, shall make good any damage to any part of the work caused by such failure. It is hereby agreed that the Performance Bond shall fully cover all guarantees contained in this Article.

It is also agreed that all warranties, expressed or implied, inure to the benefit of the City and are enforceable by the City.

SECTION 7 CHANGES

ARTICLE 7.01 MINOR CHANGES

The City reserves the right to make such additions, deductions, or changes to this Contract from time to time as

it deems necessary and in a manner not materially affecting the substance thereof or materially changing the price to be paid in order to carry out and complete more fully and perfectly the work herein agreed to be done and performed. This Contract shall in no way be invalidated by any such additions, deductions, or changes, and no claim by the Contractor shall be made for any loss of anticipated profits thereby.

Construction conditions may require that minor changes be made in the location and installation of the work and equipment to be furnished and other work to be performed hereunder, and the Contractor when ordered by the Engineer, shall make such adjustments and changes in said locations and work as may be necessary, without additional cost to the City, provided such adjustments and changes do not alter the character, quantity or cost of the work as a whole, and provided further that Plans and Specifications showing such adjustments and changes are furnished to the Contractor by the City within a reasonable time before any work involving such adjustment and changes is begun. The Engineer shall be the sole judge of what constitutes a minor change for which no additional compensation shall be allowed.

ARTICLE 7.02 EXTRA WORK

The City may at any time by a written order and without notice to the sureties require the performance of such extra work as it may find necessary or desirable. An order for extra work shall be valid only if issued in writing and signed by the Mayor and the work so ordered must be performed by the Contractor.

The amount of compensation to be paid to the Contractor for any extra work as so ordered shall be determined as follows:

(a) By such applicable unit prices, if any, as are set forth in the Proposal; or

(b) If no such unit prices are set forth then by a lump sum or other unit prices mutually agreed upon by the City and the Contractor; or

(c) If no such unit prices are set forth in the Proposal and if the parties cannot agree upon a lump sum or other unit prices then by the actual net cost in money to the Contractor of the extra work performed, which cost shall be determined as follows:

(1) For all labor and foreman in direct charge of the authorized operations, the Contractor shall receive the current local rate of wages to be agreed upon, in writing, before starting such work for each hour that said labor and foremen are actually engaged thereon, to which shall be added an amount equal to 25 percent of the sum thereof which shall be considered and accepted as full compensation for general supervision, FICA taxes, contributions under the Florida Unemployment Compensation Act, insurance, bond, subcontractor's profit and overhead, the furnishing of small tools and miscellaneous equipment used, such as picks, shovels, hand pumps, and similar items.

(2) For all materials used, the Contractor shall receive the actual cost of such materials delivered at the site or previously approved delivery point as established by original receipted bills. No percentage shall be added to this cost.

(3) For special equipment and machinery such as power-driven pumps, concrete mixers, trucks, and tractors, or other equipment, required for the economical performance of the authorized work, the Contractor shall receive payment based on the average local area rental price for each item of equipment and the actual time of its use on the work. No percentage shall be added to this sum.

(4) Records of extra work done under this procedure shall be reviewed at the end of each day by the Contractor or his representative and the Engineer. Duplicate copies of accepted records shall be made and signed by both Contractor or his representative and the Engineer, and one copy retained by each.

Request for payment for approved and duly authorized extra work shall be submitted in the same form as Contract work or in the case of work performed under paragraph (c) (1) above upon a certified statement supported by receipted bills. Such statement shall be submitted for the current Contract payment for the month in which the work was done.

ARTICLE 7.03 DISPUTED WORK

If the Contractor is of the opinion that any work required, necessitated, or ordered violates the terms and provisions of this Contract, he must promptly notify the Engineer, in writing, of his contentions with respect thereto and request a final determination thereof. If the Engineer determines that the work in question is Contract work and not extra work or that the order complained of is proper, he will direct the Contractor to proceed and the Contractor shall promptly comply. In order, however, to reserve his right to claim compensation for such work or damages resulting from such compliance, the Contractor must, within five (5) days after receiving notice of the Engineer's determination and direction, notify the City in writing that the work is being performed or that the determination and direction is being complied with under protest. Failure of the Contractor to notify shall be deemed as a waiver of claim for extra compensation or damages therefor.

Before final acceptance by the City, all matters of dispute must be adjusted to the mutual satisfaction of the parties thereto. Final determinations and decisions, in case any questions shall arise, shall constitute a condition precedent to the right of the Contractor to receive the money therefor until the matter in question has been adjusted.

ARTICLE 7.04 OMITTED WORK

The City may at any time by a written order and without notice to the sureties require the omission of such Contract work as it may find necessary or desirable.

An order for omission of work shall be valid only if signed by the Mayor and the work so ordered must be omitted by the Contractor. The amount by which the Contract price shall be reduced shall be determined as follows:

(a) By such applicable unit prices, if any, as are set forth in the Contract; or

(b) By the appropriate lump sum price set forth in the Contract; or

(c) By the fair and reasonable estimated cost to the City

of such omitted work as determined by the Engineer and approved by the City.

SECTION 8 CONTRACTOR'S EMPLOYEES

ARTICLE 8.01 CHARACTER AND COMPETENCY

The Contractor and his subcontractors shall employ upon all parts of the work herein contracted for only competent, skillful, and trustworthy workers. Should the Engineer at any time give notice, in writing, to the Contractor or his duly authorized representative on the work that any employee in his opinion is incompetent, unfaithful, disorderly, careless, unobservant of instructions, or in any way a detriment to the satisfactory progress of the work, such employee shall immediately be dismissed and not again allowed upon the site.

ARTICLE 8.02 SUPERINTENDENCE

The Contractor shall give his personal supervision to the faithful prosecution of the work and in case of his absence shall have a competent, experienced, and reliable supervisor or superintendent, acceptable to the Engineer on the site who shall follow without delay all instructions of the Engineer in the prosecution and completion of the work and every part thereof, in full authority to supply workers, material, and equipment immediately. He shall keep on hand at all times copies of the Contract Documents.

ARTICLE 8.03 EMPLOYMENT OPPORTUNITIES

The Contractor shall, in the performance of the work required to be done under this Contract, employ all workers without discrimination regarding race, creed, color, sex or national origin and must not maintain or provide facilities that are segregated on the basis of race, color, creed or national origin.

ARTICLE 8.04 RATES OF WAGES

On federally assisted projects, the rates of wages to be paid under this Contract shall not be less than the rates of wages set forth in Section 12 of this Agreement.

On other projects, no wage rate determination is included. Florida's Prevailing Wage Law (Section 215.19, Florida Statutes) was repealed effective April 25, 1979.

ARTICLE 8.05 PAYROLL REPORTS

The Contractor and each subcontractor shall, if requested to do so, furnish to the Engineer a duly certified copy of his payroll and also any other information required by the Engineer to satisfy him that the provisions of the law as to the hours of employment and rate of wages are being observed.

Payrolls shall be prepared in accordance with instructions furnished by the City and on approved forms. The Contractor shall not carry on his payroll any persons not employed by him. Subcontractor's employees shall be carried only on the payrolls of the employing subcontractor.

SECTION 9 CONTRACTOR'S DEFAULT

ARTICLE 9.01 CITY'S RIGHT AND NOTICE

It is mutually agreed that: (a) if the Contractor fails to begin work when required to do so, or (b) if at any time during the progress of the work it shall appear to the Engineer that the Contractor is not prosecuting the work with reasonable speed, or is delaying the work unreasonably and unnecessarily, or (c) if the force of workmen or quality or quantity of material furnished are not sufficient to insure completion of the work within the specified time and in accordance with the Specifications hereto attached, or (d) if the Contractor shall fail to make prompt payments for materials or labor or to subcontractors for work performed under the Contract, or (e) if legal proceedings have been instituted by others than the City in such manner as to interfere with the progress of the work and may subject the City to peril of litigation or outside claims of (f) if the Contractor shall be adjudged a bankrupt or make an assignment for the benefit of creditors, or (g) if in any proceeding instituted by or against the Contractor an order shall be made or entered granting an extension of time of payment, composition, adjustment, modification, settlement or satisfaction of his debts or liabilities, or (h) if a receiver or trustee shall be appointed for the Contractor or the Contractor's property, or (i) if the Contract or any part thereof shall be sublet without the consent of the City being first obtained in writing, or (j) if this Contract or any right, monies, or claim thereunder shall be assigned by the Contractor, otherwise than as herein specified, or (k) if the Contractor shall fail in any manner of substance to observe the provisions of this Contract, or (l) if any of the work, machinery, or equipment shall be defective, and shall not be replaced as herein provided, or (m) if the work to be done under this Contract shall be abandoned, then such fact or conditions shall be certified by the Engineer and thereupon the City without prejudice to any other rights or remedies of the City, shall have the right to declare the Contractor in default and so notify the Contractor by a written notice, setting forth the ground or grounds upon which such default is declared and the Contractor must discontinue the work, either as a portion of the work or the whole thereof, as directed.

ARTICLE 9.02 CONTRACTOR'S DUTY UPON DEFAULT

Upon receipt of notice that his Contract is in default, the Contractor shall immediately discontinue all further operations on the work or such part thereof, and shall immediately quit the site or such part thereof, leaving untouched all plant, materials, equipment, tools, and supplies.

ARTICLE 9.03 COMPLETION OF DEFAULTED WORK

The City, after declaring the Contractor in default, may then have the work completed or the defective equipment or machinery replaced or anything else done to complete the work in strict accordance with the Contract Documents by such means and in such manner, by Contract with or without public letting, or otherwise, as it may deem advisable,

utilizing for such purpose without additional cost to the City such of the Contractor's plant, materials, equipment, tools, and supplies remaining on the site, and also such subcontractors as it may deem advisable.

The City shall reimburse all parties, including itself, for the expense of such completion, including liquidated damages, if any, and the cost of reletting. The City shall deduct this expense from monies due or to become due to the Contractor under this Contract, or any part thereof, and in case such expense is more than the sum remaining unpaid of the original contract price, the Contractor and his sureties shall pay the amount of such deficiency to the City.

ARTICLE 9.04 PARTIAL DEFAULT

In case the City shall declare the Contractor in default as to a part of the work only, the Contractor shall discontinue such part, shall continue performing the remainder of the work in strict conformity with the terms of the Contract, and shall in no way hinder or interfere with any other contractor or person whom the City may engage to complete the work as to which the Contractor was declared in default.

SECTION 10 PAYMENTS

ARTICLE 10.01 PRICES

For the Contractor's complete performance of the work, the City will pay and the Contractor agrees to accept, subject to the terms and conditions hereof, the lump sum prices or unit prices in the Contractor's Proposal and the award made therein, plus the amount required to be paid for any extra work ordered under Article 7.02 hereof, less credit for any work omitted pursuant to Article 7.04 hereof. Under unit price items, the number of units actually required to complete the work under the Contract may be more than stated in the Proposal. The Contractor agrees that no claim will be made for any damages or for loss of profits because of a difference between the quantities of the various classes of work assumed and stated in the Proposal Form as a basis for comparing Proposals and the quantities of work actually performed.

The sum as awarded for any lump sum Contract or lump sum Contract Item shall represent payment in full for all of the various classes of work, including materials, equipment, and labor necessary or required to complete, in conformity with the Contract Document, the entire work shown, indicated or specified under the lump sum Contract or lump sum Contract Item.

The amount as awarded as a unit price for any unit price Contract Item shall represent payment in full for all the materials, equipment, and labor necessary to complete, in conformity with the Contract Documents, each unit of work shown, specified, or required under the said unit price Contract Item.

No payment other than the amount as awarded will be made for any class of work included in a lump sum Contract Item or a unit price Contract Item, unless specific provision is

made therefor in the Contract Documents.

ARTICLE 10.02 SUBMISSION OF BID BREAKDOWN

Within fifteen (15) days after the execution of this Contract, the Contractor must submit to the Engineer in duplicate an acceptable breakdown of the lump sums and unit prices bid for items of the Contract, showing the various operations to be performed under the Contract, as described in the progress schedule required under Article 4.02 hereof, and the value of each of such operations, the total of such items to equal the total price bid. The Contractor shall also submit such other information relating to the bid prices as may be required and shall revise the bid breakdown as directed. Thereafter, the breakdown may be used for checking the Contractor's applications for partial payments hereunder but shall not be binding upon the City or the Engineer for any purpose whatsoever.

ARTICLE 10.03 REPORTS, RECORDS AND DATA

The Contractor shall furnish to the Engineer such schedules of quantities and costs, progress schedules, reports, invoices, delivery tickets, estimates, records, and other data as the Engineer may request concerning work performed or to be performed and the materials furnished under the Contract.

ARTICLE 10.04 PAYMENTS BY CONTRACTOR

The Contractor shall pay (a) for all transportation and utility services not later than the 20th day of the calendar month following that in which such services are rendered, (b) for all materials, tools, and equipment delivered at the site of the project, and the balance of the cost thereof not later than the 30th day following the completion of that part of the work in or on which such materials, tools, and equipment are incorporated or used, and (c) to each of his subcontractors, not later than the 5th day following each payment to the Contractor, the respective amounts allowed the Contractor on account of the work performed by his subcontractors, to the extent of each subcontractor's interest therein; and proof of such payments or releases therefor shall be submitted to the Engineer upon request.

ARTICLE 10.05 PARTIAL PAYMENTS

On or about the first of each month, the Contractor shall make and certify an estimate, on forms prescribed by the City, of the amount and fair value of the work done, and may apply for partial payment therefor. The Contractor shall revise the estimate as the Engineer may direct. When satisfactory progress has been made, and shows that the value of the work completed since the last payment exceeds one percent (1%) of the total Contract price in amount, the Engineer will issue a certificate that such work has been completed and the value thereof. The City will then issue a voucher to the Contractor in accordance with the following schedule:

FOR CONTRACT AMOUNTS UNDER \$250,000

(A) In the amount of ninety percent (90%) of the value of the work completed as certified until construction is one hundred percent (100%) complete (operational or beneficial occupancy), the withheld amount may be reduced below ten percent (10%), at the Engineer's option, to only that amount necessary to assure completion.

FOR CONTRACT AMOUNTS OVER \$250,000

(A) In the amount of ninety percent (90%) of the value of the work completed as certified until construction is fifty percent (50%) complete.

(B) When the dollar value, as determined by the Engineer, of satisfactorily completed work in place is greater than fifty percent (50%) of the original contract price, vouchers for partial payment will be issued by the City to the Contractor in the amount of one hundred percent (100%) of the value of the work, above 50%, completed as certified for that payment period.

(C) If the Contractor has performed satisfactorily and the work is substantially complete (operational or beneficial occupancy) the withheld amount may be reduced, at the Engineer's option, to only that amount necessary to assure completion.

In addition to the Conditions set forth in (A), (B), and (C) above, payments will always be less any sums that may be retained or deducted by the City under the terms of any of the contract documents and less any sums that may be retained to cover monetary guarantees for equipment, materials or progress performance.

Payment on estimates made on or about the first of the month may be expected on or about the 20th of the month.

Unless specified otherwise in the Contract Items, the delivered cost of equipment and nonperishable materials suitably stored at the site of the work and tested for adequacy may be included in the Contractor's application for partial payment provided, however, that the Contractor shall furnish evidence satisfactory to the City that the Contractor is the unconditional owner and in possession of such materials or equipment. The amount to be paid will be 90 percent of the invoice cost to the Contractor which cost shall be supported by receipted bills within 30 days of the date of payment by the City to the Contractor. Such payment shall not relieve the Contractor from full responsibility for completion of the work and for protection of such materials and equipment until incorporated in the work in a permanent manner as required by the Contract Documents.

Before any payment will be made under this Contract, the Contractor and every subcontractor, if required, shall deliver to the Engineer a written, verified statement, in satisfactory form, showing in detail all amounts then due and unpaid by such Contractor or subcontractor to all laborers, workmen, and mechanics, employed by him under the Contract for the performance of the work at the site thereof, for daily or weekly wages, or to other persons for materials, equipment, or supplies delivered at the site of the work during the period covered by the payment under consideration.

ARTICLE 10.06 FINAL PAYMENT

Under determination of satisfactory completion of the work under this Contract as provided in Article 4.07 hereof, the Engineer will prepare the final estimate showing the value of the completed work. This estimate will be prepared within 30 days after the date of completion or as soon thereafter as the necessary measurements and computations can be made.

All prior certificates and estimates, being approximate only, are subject to correction in the final estimate and payment.

When the final estimate has been prepared and certified by Engineer, he will submit to the Mayor and City Council the final certificate stating that the work has been completed and the amount based on the final estimate remaining due to the Contractor. The City will then accept the work as fully completed and will, not later than 30 days after the final acceptance, as defined in Article 1.02, of the work done under this Contract, pay the Contractor the entire amount so found due thereunder after deduction of all previous payments and all percentages and amounts to be kept and retained under provisions of this Contract; provided, however, and it is understood and agreed that, as a precedent to receiving final payment, the Contractor shall submit to the City a sworn affidavit that all bills for labor, service, materials, and subcontractors have been paid and that there are no suits pending in connection with this work. The City, at its option, may permit the Contractor to execute a separate surety bond in a form satisfactory to the City. The surety bond shall be in the full amount of the suit or suits.

Neither the final payment nor any part of the retained percentage shall be paid until the Contractor, if required, shall furnish the City with a complete release from any should remain unsatisfied after all payments are made, the Contractor shall refund to the City all monies which the City may be compelled to pay in discharging such claim, including incidental costs and attorney's fees.

ARTICLE 10.07 ACCEPTANCE OF FINAL PAYMENT

The acceptance by the Contractor, or by anyone claiming by or through him, of the final payment shall operate as and shall be a release to the City and every officer and agent thereof from any and all claims and liability to the Contractor for anything done or furnished in connection with the work or project and for any act or neglect of the Contractor or of any others relating to or affecting the work. No payment, however, final or otherwise, shall operate to release the Contractor or his sureties from any obligations under this Contract or the Performance Bond.

SECTION 11 MISCELLANEOUS PROVISIONS

ARTICLE 11.01 CONTRACTOR'S WARRANTIES

In consideration of, and to induce the award of this contract to him, the Contractor represents and warrants:

- (a) That he is not in arrears to the City upon debt or contract, and he is not a defaulter, as surety, contractor, or otherwise.
- (b) That he is financially solvent and sufficiently experienced and competent to perform the work.
- (c) That the work can be performed as called for by the Contract Documents.
- (d) That the facts stated in his proposal and the information given by him are true and correct in all respects.
- (e) That he is fully informed regarding all the conditions affecting the work to be done and labor and materials to be

furnished for the completion of this Contract, and that his information was secured by personal investigation and research.

ARTICLE 11.02 PATENTED DEVICES, MATERIAL AND PROCESSES

It is mutually understood and agreed that Contract prices include all royalties and costs arising from patents, trademarks, and copyrights in any way involved in the work. Whenever the Contractor is required or desires to use any design, device, material, or process covered by letters of patent or copyright, the Contractor shall indemnify and save harmless the City, its officers, agents and employees from any and all claims for infringement by reason of the use of any such patented design, device, tool, material, equipment, or process, to be performed under the Contract, and shall indemnify the said City, its officers, agents, and employees for any costs, expenses, and damages which may be incurred by reason of such infringement at any time during the prosecution or after completion of the work.

ARTICLE 11.03 SUITS AT LAW

In case any action at law or suit in equity may or shall be brought against the City or any of its officers, agents, or employees for or on account of the failure, omission, or neglect of the Contractor or his subcontractors, employees, or agents, to do or perform any of the covenants, acts, matters, or things by this Contract undertaken to be done or performed by the Contractor or his subcontractors, employees, or agents, or from any injuries done to property or persons and caused by the negligence or alleged negligence of the Contractor or his subcontractors, employees, or agents, or in any other manner arising out of the performance of this Contract, then the Contractor shall immediately assume and take charge of the defense of such actions or suits in like manner and to all intents and purposes as if said actions or suits have been brought directly against the Contractor, and the Contractor shall also indemnify and save harmless the City, its officers, agents, and employees from any and all loss, cost or damage whatever arising out of such actions or suits, in like manner and to all intents and purposes as if said actions or suits have been brought directly against the Contractor.

The Contractor shall and does hereby assume all liability for and agrees to indemnify the City or its Engineer against any or all loss, costs, damages, and liability for any or by reason of any lien, claims or demands, either for materials purchased or for work performed by laborers, mechanics, and others and from any damages, costs, actions, or causes of action and judgement arising from injuries sustained by mechanics, laborers, or other persons by reason of accidents or otherwise, whether caused by the carelessness or inefficiency or neglect of said Contractor, his subcontractors, agents, employees, workmen or otherwise.

ARTICLE 11.04 CLAIMS FOR DAMAGES

If the Contractor shall claim compensation for any damage sustained, other than for extra or disputed work covered by Article 7.02 and 7.03 hereof, by reason of any act or omission of the City, its agents, or any persons, he shall, within five days after sustaining such damage, make and

deliver to the Engineer a written statement of the nature of the damage sustained and of the basis of the claim against the City. On or before the 15th of the month succeeding that in which any damage shall have been sustained, the Contractor shall make and deliver to the Engineer an itemized statement of the details and amounts of such damage, duly verified by the Contractor. Unless such statements shall be made delivered within the times aforesaid, it is stipulated that and all claims for such compensation shall be forfeited and invalidated, and the Contractor shall not be entitled to payment on account of such claims.

ARTICLE 11.05 NO CLAIMS AGAINST INDIVIDUALS

No claim whatsoever shall be made by the Contractor against any officer, agent, employee of the City for, or on account of, anything done or omitted to be done in connection with this Contract.

ARTICLE 11.06 LIABILITY UNAFFECTED

Nothing herein contained shall in any manner create any liability against the City on behalf of any claim for labor, services, or materials, or of subcontractors, and nothing herein contained shall affect the liability of the Contractor or his sureties to the City or to any workmen or materialsmen upon bond given in connection with this Contract.

ARTICLE 11.07 INDEMNIFICATION PROVISIONS

Whenever there appears in this Agreement, or in the other Contract Documents made a part hereof, an indemnification provision within the purview of Chapter 725.06, Laws of Florida, the monetary limitation on the extent of the indemnification under each such provision shall be One Million Dollars or a sum equal to the total Contract price, whichever shall be the greater.

ARTICLE 11.08 UNLAWFUL PROVISIONS DEEMED STRICKEN

If this contract contains any unlawful provisions not an essential part of the Contract and which shall not appear to have a controlling or material inducement to the making thereof, such provisions shall be deemed of no effect and shall, upon notice by either party, be deemed stricken from the Contract without affecting the binding force of the remainder.

ARTICLE 11.09 LEGAL PROVISIONS DEEMED INCLUDED

Each and every provision of any law and clause required by law to be inserted in this Contract shall be deemed to be inserted herein, and the Contract shall be read and enforced as though it were included herein and if, through mistake or otherwise, any such provision is not inserted or is not correctly inserted, then upon application of either party the Contract shall forthwith be physically amended to make such insertion.

ARTICLE 11.10 DEATH OR INCOMPETENCY OF CONTRACTOR

In the event of death or legal incompetency of a Contractor who shall be an individual or surviving member of a contracting firm, such death or adjudication of incompetency

shall not terminate the Contract, but shall act as default hereunder to the effect provided in Article 9.01 hereof and the estate of the Contractor and his surety shall remain liable hereunder to the same extent as though the Contractor had lived. Notice of default, as provided in Article 9.01 hereof, shall not be required to be given in the event of such death or adjudication of incompetency.

ARTICLE 11.11 NUMBER AND GENDER OF WORDS

Whenever the context so admits or requires, all references herein in one number shall be deemed extended to and including the other number, whether singular or plural, and the use of any gender shall be applicable to all genders.

ARTICLE 11.12 ACCESS TO RECORDS

Representatives of Federal Agencies, if applicable, and the State of Florida shall have access to the work whenever it is in preparation of progress. On federally assisted projects the Federal Agency, the Comptroller General of the United States, or any authorized representative shall have access to any books, documents, papers, and records of the Contractor which are pertinent to the project for the purpose of making audit, examination, excerpts, and transcription thereof.

**SECTION 12
LABOR STANDARDS**

ARTICLE 12.01 LABOR STANDARDS

The Contractor shall comply with all of the regulations set forth in "Labor Standards Provisions for Federally Assisted Construction Contracts", which may be attached, and any applicable Florida Statutes.

ARTICLE 12.02 NOTICE TO LABOR UNIONS

If required, the Contractor shall provide Labor Unions and other organizations of workers, and shall post, in a conspicuous place available to employees or applicants for employment, a completed copy of the form entitled "Notice to Labor Unions or Other Organizations of Workers" attached to and made a part of this Agreement.

ARTICLE 12.03 SAFETY AND HEALTH REGULATIONS

The Contractor shall comply with the Department of Labor Safety and Health Regulations for construction promulgated under the Occupational Safety and Health Act of 1970 (PL 91- 596) and under Section 107 of the Contract Work Hours and Safety Standards Act (PL 91-54). Nothing in these Acts shall be construed to supersede or in any manner affect any worker's compensation law or statutory rights, duties, or liabilities of employers and employees under any law with respect to injuries, diseases, or death of employees arising out of, or in the course of, employment.

ARTICLE 12.04 EEO AFFIRMATIVE ACTION REQUIREMENTS

The Contractor understands and agrees to be bound by the equal opportunity requirements of Federal regulations which shall be applicable throughout the performance of work under this Contract. The Contractor also agrees to similarly

bind contractually each subcontractor. In policies, the Contractor agrees to engage in Affirmative Action directed at promoting and ensuring equal employment opportunity in the work force used under the Contract (and the Contractor agrees to require contractually the same effort of all subcontractors whose subcontractors exceed \$100,000). The Contractor understands and agrees that "Affirmative Action" as used herein shall constitute a good faith effort to achieve and maintain minority employment in each trade in the on-site work force used on the Contract.

ARTICLE 12.05 PREVAILING RATES OF WAGES

Florida's prevailing wage law was repealed effective April 25, 1979.

For Federally assisted projects, appropriate prevailing wage rate determinations are indicated on pages beginning with WR-1.

* * * * *

IN WITNESS THEREOF, the parties have hereunto set their hands and seals, and such of them as are corporation have caused these present to be signed by their duly authorized officers.

CITY OF TAMPA, FLORIDA

Jane Castor, Mayor
(SEAL)

ATTEST:

City Clerk

Approved as to Form:
The execution of this document was authorized
by Resolution No. _____

e/s
Marcella T. Hamilton, Assistant City Attorney

Contractor

By: _____
(SEAL)

Title:

ATTEST:

Witness

TAMPA AGREEMENT (ACKNOWLEDGMENT OF PRINCIPAL)

STATE OF _____)
) SS:
COUNTY OF _____)

For a Corporation:

STATE OF _____
COUNTY OF _____

The forgoing instrument was Sworn to (or affirmed) and subscribed before me by means of physical presence or online notarization, this _____ day of _____, 20____, by _____ as _____ of _____, a/n

Partnership Joint Venture LLC Corp Other: _____, on behalf of such entity. Such individual is Personally Known OR Produced Identification. Type of Identification Produced _____.

[NOTARY SEAL]

Notary Public, State of _____
Notary Printed Name: _____
Commission No.: _____
My Commission Expires: _____

For a Firm:

STATE OF _____
COUNTY OF _____

The forgoing instrument was Sworn to (or affirmed) and subscribed before me by means of physical presence or online notarization, this _____ day of _____, 20____, by _____ as _____ of _____, a/n

Partnership Joint Venture LLC Corp Other: _____, on behalf of such entity. Such individual is Personally Known OR Produced Identification. Type of Identification Produced _____.

[NOTARY SEAL]

Notary Public, State of _____
Notary Printed Name: _____
Commission No.: _____
My Commission Expires: _____

PUBLIC CONSTRUCTION BOND

Bond No. (enter bond number) _____

Name of Contractor: _____

Principal Business Address of Contractor: _____

Telephone Number of Contractor: _____

Name of Surety (if more than one list each): _____

Principal Business Address of Surety: _____

Telephone Number of Surety: _____

Owner is The City of Tampa, Florida

Principal Business Address of Owner: _____ 306 E Jackson St, Tampa, FL 33602

_____ Contract Administration Department (280A4N)

Telephone Number of Owner: _____ 813/274-8456

Contract Number Assigned by City to contract which is the subject of this bond: _____

Legal Description or Address of Property Improved or Contract Number is: _____

General Description of Work and Services: _____

KNOW ALL MEN BY THESE PRESENTS That we, _____

(Name of Contractor)

as Principal, hereinafter called CONTRACTOR, of the State of _____, and

(Name of Surety)

a corporation organized and existing under and by virtue of the laws of the State of _____, and regularly authorized to do business in the State of Florida, as SURETY, are held and firmly bound unto the City of Tampa, a municipal corporation organized and existing under the laws of the State of Florida, hereinafter called Owner, in the penal sum of _____ Dollars and _____ Cents (\$ _____), lawful money of the United States of America, for the payment whereof well and truly to be made, we bind ourselves, our heirs, executors, and administrators, successors and assigns, jointly and severally, firmly by these presents.

THE CONDITION OF THIS BOND is that if Principal:

1. Performs the contract dated _____, _____, 20____, between Principal and Owner for construction of _____, the contract being made a part of this bond by reference, in the time and in the manner prescribed in the contract; and
2. Promptly makes payments to all claimants, as defined in Section 255.05(1) (Section 713.01), Florida Statutes, supplying Principal with labor, materials, or supplies, used directly or indirectly by Principal in the prosecution of the work provided for in the contract; and
3. Pays Owner all losses, damages, expenses, costs, and attorney's fees, including appellate proceedings, that Owner sustains because of a default by Principal under the contract; and
4. Performs the guarantee of all work and materials furnished under the contract for the time specified in the contract, then this bond is void; otherwise it remains in full force.
5. Contractor and Surety acknowledge that the Work for which this bond has been issued may be one of several such contract documents for a group of projects. This bond does not secure covenants to pay for or to perform design services survey or program management services. The Owner/Obligee is expected to reasonably account for damages that are caused to Owner with respect to Principal's (Contractor's) default in performance of the scope of the Work incorporated by reference into the bond, and notwithstanding any contractual or common law remedy permitted to Owner as against Contractor, the obligation of Surety for any damages under this bond shall be determined by the cost of completion of the Work less the contract balance unpaid upon default of Contractor for the Work plus liquidated damages at the rate of \$500.00 per day for delays by the Contractor and/or Surety in reaching substantial completion.
6. The notice requirements for claimants and conditions for entitlement to payment set forth in Section 255.05, Fla. Stat. and the limitations period to actions upon Section 255.05, Fla. Stat. bonds apply to claimants seeking payment from surety under this bond. Any action instituted by a claimant under this bond for payment must be in accordance with the notice and time limitation provisions in Section 255.05, Florida Statutes.
7. The Surety, for value received, hereby stipulates and agrees that no changes, extensions of time, alterations or additions to the terms of the contract documents or other Work to be performed hereunder, or the specifications referred to therein shall in any way affect its obligations under this bond, and it does hereby waive notice of any such changes, extensions of time, alterations or additions to the terms of the Contract or to Work or to the specifications.

8. The above SURETY states that it has read all of the Contract Documents made by the CONTRACTOR with the CITY, hereto attached, and the terms and conditions of the contract and work, and is familiar therewith and in particular those portions of the Agreement concerning the guaranty of such CONTRACTOR for a period of one year following the date of the final acceptance of the completed work under the Contract by the CITY, all of which this BOND includes.

DATED ON _____, 20__

(Name of Principal)

(Name of Surety)

(Principal Business Address)

(Surety Address)

By _____

By _____
(As Attorney in Fact)*

Title _____

Telephone Number of Surety

Telephone Number of Principal

Approved as to legal sufficiency:

Countersignature:

By _____ e/s
Marcella T. Hamilton, Assistant City Attorney

(Name of Local Agency)

(Address of Resident Agent)

By _____

Title _____

Telephone Number of Local Agency

*(As Attorney in Fact) attach Power of Attorney and Current Certificate with Original Signature

SPECIFICATIONS GENERAL PROVISIONS

SECTION 1 SCOPE AND INTENT

G-1.01 DESCRIPTION

The work to be done consists of the furnishing of all labor, materials and equipment, and the performance of all work included in this Contract.

G-1.02 WORK INCLUDED

The Contractor shall furnish all labor, superintendence, materials, plant, power, light, heat, fuel, water, tools, appliances, equipment, supplies, and other means of construction necessary or proper for performing and completing the work. He shall obtain and pay for all required permits. He shall perform and complete the work in the manner best calculated to promote rapid construction consistent with safety of life and property and to the satisfaction of the Engineer, and in strict accordance with the Contract Documents. The Contractor shall clean up the work and maintain it during and after construction, until accepted, and shall do all work and pay all costs incidental thereto. He shall repair or restore all structures and property that may be damaged or disturbed during performance of the work.

The cost of incidental work described in these General Provisions, for which there are no specific Contract Items, shall be considered as part of the overhead cost of doing the work and shall be included in the prices for the various Contract Items. No additional payment will be made therefor.

The Contractor shall provide and maintain such modern plant, tools, and equipment as may be necessary, in the opinion of the Engineer, to perform in a satisfactory and acceptable manner all the work required by this Contract. Only equipment of established reputation and proven efficiency shall be used. The Contractor shall be solely responsible for the adequacy of his plant and equipment, prior approval of the Engineer notwithstanding.

G-1.03 PUBLIC UTILITY INSTALLATIONS AND STRUCTURES

Public utility installations and structures shall be understood to include all poles, tracks, pipes, wires, conduits, house service connections, vaults, manholes, and all other appurtenances and facilities pertaining thereto whether owned or controlled by the City, other governmental bodies or privately owned by individuals, firms, or corporations, and used to serve the public with transportation, traffic control, gas, electricity, telephone, sewerage, drainage, water or other public or private property which may be affected by the work.

The Contract Documents contain data relative to existing public utility installations and structures above and below the ground surface. These data are not guaranteed as to their completeness or accuracy and it is the responsibility of the Contractor to make his own investigations to inform himself

fully of the character, condition and extent of all such installations and structures as may be encountered and as may affect the construction operations.

The Contractor shall protect all public utility installations and structures from damage during the work. Access across any buried public utility installation or structure shall be made only in such locations and by means approved by the Engineer. The Contractor shall so arrange his operations as to avoid any damage to these facilities. All required protective devices and construction shall be provided by the Contractor at his expense. All existing public utilities damaged by the Contractor which are shown on the Plans or have been located in the field by the utility shall be repaired by the Contractor, at his expense, as directed by the Engineer. No separate payment shall be made for such protection or repairs to public utility installations or structures.

Public utility installations or structures owned or controlled by the City or other governmental body which are shown on the Plans to be removed, relocated, replaced or rebuilt by the Contractor shall be considered as a part of the general cost of doing the work and shall be included in the prices bid for the various Contract Items. No separate payment shall be made therefor.

Where public utility installations or structures owned or controlled by the City or other governmental body are encountered during the course of the work, and are not indicated on the Plans or in the Specifications, and when, in the opinion of the Engineer, removal, relocation, replacement or rebuilding is necessary to complete the work under this Contract, such work shall be accomplished by the utility having jurisdiction or such work may be ordered, in writing by the Engineer, for the Contractor to accomplish. If such work is accomplished by the utility having jurisdiction it will be carried out expeditiously and the Contractor shall give full cooperation to permit the utility to complete the removal, relocation, replacement or rebuilding as required. If such work is accomplished by the Contractor, it will be paid for as extra work as provided for in Article 7.02 of the Agreement.

The Contractor shall, at all times in performance of the work, employ approved methods and exercise reasonable care and skill so as to avoid unnecessary delay, injury, damage or destruction of public utility installations and structures; and shall, at all times in the performance of the work, avoid unnecessary interference with, or interruption of, public utility services, and shall cooperate fully with the owners thereof to that end.

All City and other governmental utility departments and other owners of public utilities, which may be affected by the work, will be informed in writing by the Engineer within two weeks after the execution of the Contract or Contracts covering the work. Such notice will set out, in general, and direct attention to, the responsibilities of the City and other governmental

utility departments and other owners of public utilities for such installations and structures as may be affected by the work and will be accompanied by one set of Plans and Specifications covering the work under such Contract or Contracts.

In addition to the general notice given by the Engineer, the Contractor shall give written notice to all City and other governmental utility departments and other owners of public utilities of the location of his proposed construction operations, at least forty-eight (48) hours in advance of breaking ground in any area or on any unit of the work. This can be accomplished by making the appropriate contact with the "Underground Utility Notification Center for Excavators (Call Candy)".

The maintenance, repair, removal, relocation, or rebuilding of public utility installations and structures, when accomplished by the Contractor as herein provided, shall be done by methods approved by the Engineer.

SECTION 2 PLANS AND SPECIFICATIONS

G-2.01 PLANS

The Plans referred to in the Contract Documents bear the general project name and number as shown in the Notice To Bidders.

When obtaining data and information from the Plans, figures shall be used in preference to scaled dimensions, and large scale drawings in preference to small scale drawings.

G-2.02 COPIES FURNISHED TO CONTRACTOR

After the Contract has been executed, the Contractor will be furnished with five sets of paper prints, the same size as the original drawings, of each sheet of the Plans and five copies of the Specifications. Additional copies of the Plans and Specifications, when requested, may be furnished to the Contractor at cost of reproduction.

The Contractor shall furnish each of the subcontractors, manufacturers, and material suppliers such copies of the Contract Documents as may be required for his work.

G-2.03 SUPPLEMENTARY DRAWINGS

When, in the opinion of the Engineer, it becomes necessary to explain more fully the work to be done or to illustrate the work further or to show any changes which may be required, drawings known as Supplementary Drawings, with specifications pertaining thereto, will be prepared by the Engineer and five paper prints thereof will be given to the Contractor.

The Supplementary Drawings shall be binding upon the Contractor with the same force as the Plans. Where such Supplementary Drawings require either less or more than the estimated quantities of work, credit to the City or compensation therefor to the Contractor shall be subject to the terms of the Agreement.

G-2.04 CONTRACTOR TO CHECK PLANS AND DATA

The Contractor shall verify all dimensions, quantities, and details shown on the Plans, Supplementary Drawings, Schedules, Specifications, or other data received from the Engineer, and shall notify him of all errors, omissions, conflicts, and discrepancies found therein. Failure to discover or correct errors, conflicts or discrepancies shall not relieve the Contractor of full responsibility for unsatisfactory work, faulty construction or improper operation resulting therefrom nor from rectifying such conditions at his own expense. He will not be allowed to take advantage of any errors or omissions as full instructions will be furnished by the Engineer, should such errors or omissions be discovered. All schedules are given for the convenience of the Engineer and the Contractor and are not guaranteed to be complete. The Contractor shall assume all responsibility for the making of estimates of the size, kind, and quality of materials and equipment included in work to be done under the Contract.

G-2.05 SPECIFICATIONS

The specifications consist of four parts, the General Provisions, the Technical Specifications, the Special Provisions and the Contract Items. The General Provisions and Technical Specifications contain general requirements which govern the work. The Special Provisions and the Contract Items modify and supplement these by detailed requirements for the work and shall always govern, whenever there appears to be conflict.

G-2.06 INTENT

All work called for in the Specifications applicable to this Contract, but not shown on the Plans in their present form, or vice versa, shall be of like effect as if shown or mentioned in both. Work not specified in either the Plans or in the Specifications, but involved in carrying out their intent or in the complete and proper execution of the work, is required and shall be performed by the Contractor as though it were specifically delineated or described.

The apparent silence of the Specifications as to any detail, or the apparent omission from them of a detailed description concerning any work to be done and materials to be furnished, shall be regarded as meaning that only the best general practice is to prevail and that only material and workmanship of the best quality is to be used, and interpretation of these Specifications shall be made upon that basis.

SECTION 3 WORKING DRAWINGS

G-3.01 SCOPE

The Contractor shall promptly prepare and submit layout, detail and shop drawings to insure proper construction, assembly, and installation of the work using those materials and methods as hereafter specified under the Technical Specifications, Special Provisions and Contract Items.

These drawings shall accurately and distinctly present the following:

- a. All working and erection dimensions.
- b. Arrangements and sectional views.
- c. Necessary details, including complete information for making connections between work under this Contract and work under other Contracts.
- d. Kinds of materials and finishes.
- e. Parts listed and description thereof.

Drawings for mechanical equipment shall present, where applicable, such data as dimensions, weight and performance characteristics. These data shall show conformance with the performance characteristics and other criteria incorporated in the Plans and Specifications.

Each drawing shall be dated and shall contain the name of the project, Division number and description, the technical specifications section number, names of equipment or materials and the location at which the equipment or materials are to be installed. Location shall mean both physical location and location relative to other connected or attached material. The Engineer will return unchecked any submittal which does not contain complete data on the work and full information on related matters.

Stock or standard drawings will not be accepted for review unless full identification and supplementary information is shown thereon in ink or typewritten form.

The Contractor shall review all working drawing submittals before transmitting them to the Engineer to determine that they comply with requirements of the Specifications. Drawings which are incomplete or are not in compliance with the Contract Documents shall not be submitted for processing by the Engineer. The Contractor shall place his stamp of approval on all working drawings submitted to the Engineer to indicate compliance with the above.

G-3.02 APPROVAL

If the working drawings show departures from the Contract requirements, the Contractor shall make specific mention thereof in his letter of submittal; otherwise approval of such submittals shall not constitute approval of the departure. Approval of the drawings shall constitute approval of the subject matter thereof only and not of any structure, material, equipment, or apparatus shown or indicated.

The approval of drawings will be general and shall not relieve the Contractor of responsibility for the accuracy of such drawings, nor for the proper fitting and construction of the work, nor for the furnishing of materials or work required by the Contract and not indicated on the drawings. No work called for by working drawings shall be done until such drawings have been approved by the Engineer.

The procedure in seeking approval of the working drawings shall be as follows:

1. The Contractor shall submit four complete sets of drawings

and other descriptive data together with one copy of a letter of transmittal to the Engineer for approval. The letter of transmittal shall contain the name of the project, contract number, technical specifications section number, the name of the Contractor, a list of drawings with numbers and titles, and any other pertinent information.

2. Drawings or descriptive data will be stamped "Approved", "Approved Subject to Corrections Marked", or "Examined and Returned for Correction" and one copy with a letter of transmittal will be returned to the Contractor.

3. If a drawing or other data is stamped "Approved", the Contractor shall insert the date of approval on five additional copies of the document and transmit the five copies to the Engineer together with one copy of a letter of transmittal containing substantially the same information as described in Instruction 1. above.

4. If a drawing or other data is stamped "Approved Subject to Corrections Marked", the Contractor shall make the corrections indicated and proceed as in Instruction 3., above.

5. If a drawing or data is stamped "Examined and Returned for Correction", the Contractor shall make the necessary corrections and resubmit the documents as set forth in Instruction 1., above. The letter of transmittal shall indicate that this is a resubmittal.

The Contractor shall revise and resubmit the working drawings as required by the Engineer, until approval thereof is obtained.

SECTION 4 MATERIALS AND EQUIPMENT

G-4.01 GENERAL REQUIREMENTS

All materials, appliances, and types or methods of construction shall be in accordance with the Specifications and shall, in no event, be less than that necessary to conform to the requirements of any applicable laws, ordinances, and codes.

All materials and equipment shall be new, unused, and correctly designed. They shall be of standard first grade quality, produced by expert personnel, and intended for the use for which they are offered. Materials or equipment which, in the opinion of the Engineer, are inferior or of a lower grade than indicated, specified, or required will not be accepted.

The quality of Workmanship and Materials entering into the work under this Contract shall conform to the requirements of the pertinent sections, clauses, paragraphs, and sentences, both directly and indirectly applicable thereto, of that part of the Technical Specifications, whether or not direct reference to such occurs in the Contract Items.

Equipment and appurtenances shall be designed in conformity with ANSI, ASME, IEEE, NEMA and other

generally accepted standards and shall be of rugged construction and of sufficient strength to withstand all stresses which may occur during fabrication, testing, transportation, installation, and all conditions of operation. All bearings and moving parts shall be adequately protected against wear by bushings or other approved means and shall be fully lubricated by readily accessible devices. Details shall be designed for appearance as well as utility. Protruding members, joints, corners, gear covers, and the like, shall be finished in appearance. All exposed welds shall be ground smooth and the corners of structural shapes shall be mitered.

Equipment shall be of the approximate dimensions as indicated on the Plans or as specified, shall fit the spaces shown on the Plans with adequate clearances, and shall be capable of being handled through openings provided in the structure for this purpose. The equipment shall be of such design that piping and electrical connections, ductwork, and auxiliary equipment can be assembled and installed without causing major revisions to the location or arrangement of any of the facilities.

Machinery parts shall conform exactly to the dimensions shown on the working drawings. There shall be no more fitting or adjusting in setting up a machine than is necessary in assembling high grade apparatus of standard design. The equivalent parts of identical machines shall be made interchangeable. All grease lubricating fittings on equipment shall be of a uniform type. All machinery and equipment shall be safeguarded in accordance with the safety codes of the ANSI and applicable state and local codes.

G-4.02 MANUFACTURER

The names of proposed manufacturers, suppliers, material, and dealers who are to furnish materials, fixtures, equipment, appliances or other fittings shall be submitted to the Engineer for approval, as early as possible, to afford proper investigation and checking. Such approval must be obtained before shop drawings will be checked. No manufacturer will be approved for any materials to be furnished under this Contract unless he shall be of good reputation and have a plant of ample capacity. He shall, upon the request of the Engineer, be required to submit evidence that he has manufactured a similar product to the one specified and that it has been previously used for a like purpose for a sufficient length of time to demonstrate its satisfactory performance.

All transactions with the manufacturers or subcontractors shall be through the Contractor, unless the Contractor shall request, in writing to the Engineer, that the manufacturer or subcontractor deal directly with the Engineer. Any such transactions shall not in any way release the Contractor from his full responsibility under this Contract.

Any two or more pieces of material or equipment of the same kind, type or classification, and being used for identical types of service, shall be made by the same manufacturer.

G-4.03 REFERENCE TO STANDARDS

Whenever reference is made to the furnishing of materials or

testing thereof to conform to the standards of any technical society, organization or body, it shall be construed to mean the latest standard, code, specification or tentative specification adopted and published at the date of advertisement for proposals, even though reference has been made to an earlier standard, and such standards are made a part hereof to the extent which is indicated or intended.

Reference to a technical society, organization or body may be made in the Specifications by abbreviations, in accordance with the following list:

AASHTO for American Association of State Highway and Transportation Officials (formerly AASHO)
ACI for American Concrete Institute
AGMA for American Gear Manufacturer's Association
AFBMA for Anti-Friction Bearing Manufacturer's Association
AISC for American Institute of Steel Construction
AISI for American Iron and Steel Institute
ANSI for American National Standards Institute
ASCE for American Society of Civil Engineers
ASTM for American Society for Testing and Materials
ASME for American Society of Mechanical Engineers
AWS for American Welding Society
AWWA for American Water Works Association
AWPA for American Wood Preservers Association
CEMA for Conveyor Equipment Manufacturers Association
CIPRA for Cast Iron Pipe Research Association
IEEE for Institute of Electrical and Electronic Engineers
IPCEA for Insulated Power Cable Engineers Association
NEC for National Electrical Code
NEMA for National Electrical Manufacturers Association
SAE for Society of Automotive Engineers
SHBI for Steel Heating Boiler Institute
Fed.Spec. for Federal Specifications
Navy Spec. for Navy Department Specifications
U.L.,Inc. for Underwriters' Laboratories, Inc.

When no reference is made to a code, standard or specification, the Standard Specifications of the ANSI, the ASME, the ASTM, the IEEE, or the NEMA shall govern.

G-4.04 SAMPLES

The Contractor shall, when required, submit to the Engineer for approval typical samples of materials and equipment. The samples shall be properly identified by tags and shall be submitted sufficiently in advance of the time when they are to be incorporated into the work, so that rejections thereof will not cause delay. A letter of transmittal, in duplicate, from the Contractor requesting approval must accompany all such samples.

G-4.05 EQUIVALENT QUALITY

Whenever, in the Contract Documents, an article, material, apparatus, equipment, or process is called for by trade name or by the name of a patentee, manufacturer, or dealer or by reference to catalogs of a manufacturer or dealer, it shall be understood as intending to mean and specify the article, material, apparatus, equipment or process designated, or any

equal thereto in quality, finish, design, efficiency, and durability and equally serviceable for the purposes for which it is intended.

Whenever material or equipment is submitted for approval as being equal to that specified, the decision as to whether or not such material or equipment is equal to that specified shall be made by the Engineer.

Upon rejection of any material or equipment submitted as the equivalent of that specifically named in the Contract, the Contractor shall immediately proceed to furnish the designated material or equipment.

Neither the approval by the Engineer of alternate material or equipment as being equivalent to that specified nor the furnishing of the material or equipment specified, shall in any way relieve the Contractor of responsibility for failure of the material or equipment, due to faulty design, material, or workmanship, to perform the functions required of them by the Specifications.

G-4.06 DELIVERY

The Contractor shall deliver materials in ample quantities to insure the most speedy and uninterrupted progress of the work so as to complete the work within the allotted time. The Contractor shall also coordinate deliveries in order to avoid a delay in, or impediment of, the progress of the work of any related Contractor.

G-4.07 CARE AND PROTECTION

The Contractor shall be solely responsible for properly storing and protecting all materials, equipment, and work furnished under the Contract from the time such materials and equipment are delivered at the site of the work until final acceptance thereof. He shall, at all times, take necessary precautions to prevent injury or damage by water, freezing, or by inclemencies of the weather to such materials, equipment and work. All injury or damage to materials, equipment, or work resulting from any cause whatsoever shall be made good by the Contractor.

The Engineer shall, in all cases, determine the portion of the site to be used by the Contractor for storage, plant or for other purposes. If, however, it becomes necessary to remove and restack materials to avoid impeding the progress of any part of the work or interference with the work to be done by any other Contractor, the Contractor shall remove and restack such materials at his own expense.

G-4.08 TOOLS AND ACCESSORIES

The Contractor shall, unless otherwise stated in the Contract Documents, furnish with each type, kind or size of equipment, one complete set of suitably marked high grade special tools and appliances which may be needed to adjust, operate, maintain, or repair the equipment. Such tools and appliances shall be furnished in approved painted steel cases, properly labeled and equipped with good grade cylinder locks and duplicate keys.

Spare parts shall be furnished as specified.

Each piece of equipment shall be provided with a substantial nameplate, securely fastened in place and clearly inscribed with the manufacturer's name, year of manufacture, serial number, weight and principal rating data.

G-4.09 INSTALLATION OF EQUIPMENT

The Contractor shall have on hand sufficient proper equipment and machinery of ample capacity to facilitate the work and to handle all emergencies normally encountered in work of this character.

Equipment shall be erected in a neat and workmanlike manner on the foundations at the locations and elevations shown on the Plans, unless directed otherwise by the Engineer during installation. All equipment shall be correctly aligned, leveled and adjusted for satisfactory operation and shall be installed so that proper and necessary connections can be made readily between the various units.

The Contractor shall furnish, install and protect all necessary anchor and attachment bolts and all other appurtenances needed for the installation of the devices included in the equipment specified. Anchor bolts shall be as approved by the Engineer and made of ample size and strength for the purpose intended. Substantial templates and working drawings for installation shall be furnished.

The Contractor shall, at his own expense, furnish all materials and labor for, and shall properly bed in non-shrink grout, each piece of equipment on its supporting base that rests on masonry foundations. Grout shall completely fill the space between the equipment base and the foundation.

G-4.10 OPERATING INSTRUCTIONS

The Contractor, through qualified individuals, shall adequately instruct designated employees of the City in the operation and care of all equipment installed hereunder, except for equipment that may be furnished by the City.

The Contractor shall also furnish and deliver to the Engineer three complete sets for permanent files, identified in accordance with Subsection G-3.01 hereof, of instructions, technical bulletins and any other printed matter, such as diagrams, prints or drawings, containing full information required for the proper operation, maintenance, and repair, of the equipment installed and the ordering of spare parts, except for equipment that may be furnished by the City.

In addition to the above three copies, the Contractor shall furnish any additional copies that may be required for use during construction and start-up operations.

G-4.11 SERVICE OF MANUFACTURER'S ENGINEER

The Contract prices for equipment shall include the cost of furnishing a competent and experienced engineer or superintendent who shall represent the manufacturer and shall assist the Contractor, when required, to install, adjust, test and place in operation the equipment in conformity with the Contract Documents. After the equipment is placed in

permanent operation by the City, such engineer or superintendent shall make all adjustments and tests required by the Engineer to provide that such equipment is in proper and satisfactory operating condition, and shall instruct such personnel as may be designated by the City in the proper operation and maintenance of such equipment.

SECTION 5 INSPECTION AND TESTING

G-5.01 GENERAL

The Contractor's attention is hereby directed to Article 3.03 of the Agreement.

Inspection and testing of materials will be performed by the City unless otherwise specified.

For tests specified to be made by the Contractor, the testing personnel shall make the necessary inspections and tests and the reports thereof shall be in such form as will facilitate checking to determine compliance with the Contract Documents. Five copies of the reports shall be submitted and authoritative certification thereof must be furnished to the Engineer as a prerequisite for the acceptance of any material or equipment.

If, in the making of any test of any material or equipment, it is ascertained by the Engineer that the material or equipment does not comply with the Contract, the Contractor will be notified thereof and he will be directed to refrain from delivering said material and equipment, or to remove it promptly from the site or from the work and replace it with acceptable material, without cost to the City.

Tests of electrical and mechanical equipment and appliances shall be conducted in accordance with recognized test codes of the ANSI, ASME, or the IEEE, except as may otherwise be stated herein.

The Contractor shall be fully responsible for the proper operation of equipment during tests and instruction periods and shall neither have nor make any claim for damage which may occur to equipment prior to the time when the City formally takes over the operation thereof.

G-5.02 COSTS

All inspection and testing of materials furnished under this Contract will be performed by the City or duly authorized inspection engineers or inspection bureaus without cost to the Contractor, unless otherwise expressly specified.

The cost of shop and field tests of equipment and of certain other tests specifically called for in the Contract Documents shall be borne by the Contractor and such costs shall be deemed to be included in the contract price.

Materials and equipment submitted by the Contractor as the equivalent to those specifically named in the Contract may be tested by the City for compliance. The Contractor shall reimburse the City for the expenditures incurred in making

such tests on materials and equipment which are rejected for noncompliance.

G-5.03 INSPECTIONS OF MATERIALS

The Contractor shall give notice, in writing to the Engineer, sufficiently in advance of his intention to commence the manufacture or preparation of materials especially manufactured or prepared for use in or as part of the permanent construction. Such notice shall contain a request for inspection, the date of commencement and the expected date of completion of the manufacture or preparation of materials. Upon receipt of such notice the Engineer will arrange to have a representative present at such times during the manufacture as may be necessary to inspect the materials or he will notify the Contractor that inspection will be made at a point other than the point of manufacture, or he will notify the Contractor that inspection will be waived. The Contractor must comply with these provisions before shipping any material. Such inspection shall not release the Contractor from the responsibility for furnishing materials meeting the requirements of the Contract Documents.

G-5.04 CERTIFICATE OF MANUFACTURE

When inspection is waived or when the Engineer so requires, the Contractor shall furnish to him authoritative evidence in the form of Certificates of Manufacture that the materials to be used in the work have been manufactured and tested in conformity with the Contract Documents. These certificates shall be notarized and shall include copies of the results of physical tests and chemical analyses, where necessary, that have been made directly on the product or on similar products of the manufacturer.

G-5.05 SHOP TESTS OF OPERATING EQUIPMENT

Each piece of equipment for which pressure, duty, capacity, rating, efficiency, performance, function, or special requirements are specified shall be tested in the shop of the maker in a manner which shall conclusively prove that its characteristics comply fully with the requirements of the Contract Documents. No such equipment shall be shipped to the work until the Engineer notifies the Contractor, in writing, that the results of such tests are acceptable.

Five copies of the manufacturer's actual test data and interpreted results thereof, accompanied by a certificate of authenticity sworn to by a responsible official of the manufacturing company, shall be forwarded to the Engineer for approval.

The cost of the shop tests and of furnishing manufacturer's preliminary and shop test data of operating equipment shall be borne by the Contractor.

G-5.06 PRELIMINARY FIELD TESTS

As soon as conditions permit, the Contractor shall furnish all labor, materials, and instruments and shall make preliminary field tests of equipment. If the preliminary field tests disclose any equipment furnished under this Contract which does not comply with the requirements of the Contract Documents, the Contractor shall, prior to the acceptance tests, make all changes, adjustments, and replacements required.

TEMPORARY STRUCTURES

G-5.07 FINAL FIELD TESTS

Upon completion of the work and prior to final payment, all equipment and appliances installed under this Contract shall be subjected to acceptance tests as specified or required to prove compliance with the Contract Documents.

The Contractor shall furnish labor, fuel, energy, water and all other materials, equipment, and instruments necessary for all acceptance tests, at no additional cost to the City.

G-5.08 FAILURE OF TESTS

Any defects in the materials and equipment or their failure to meet the tests, guarantees or requirements of the Contract Documents shall be promptly corrected by the Contractor by replacements or otherwise. The decision of the Engineer as to whether or not the Contractor has fulfilled his obligations under the Contract shall be final and conclusive. If the Contractor fails to make those corrections or if the improved materials and equipment, when tested, shall again fail to meet the guarantees or specified requirements, the City, notwithstanding its partial payment for work, and materials and equipment, may reject the materials and equipment and may order the Contractor to remove them from the site at his own expense.

In case the City rejects any materials and equipment, then the Contractor shall replace the rejected materials and equipment within a reasonable time. If he fails to do so, the City may, after the expiration of a period of thirty calendar days after giving him notice in writing, proceed to replace such rejected materials and equipment, and the cost thereof shall be deducted from any compensation due or which may become due the Contractor under this Contract.

The City agrees to obtain other equipment within a reasonable time and the Contractor agrees that the City may use the equipment furnished by him without rental or other charges until the new equipment is obtained.

Materials or work in place that fails to pass acceptability tests shall be retested at the direction of the construction engineer all such retests shall be at the Contractor's expense. The rates charged shall be in accordance with the Department of Public Works current annual inspection contract which is available for inspection at the offices of the Department of Public Works.

G-5.09 FINAL INSPECTION

The procedures for final inspection shall be in accordance with the provisions of Article 4.07 of the Agreement. During such final inspections, the work shall be clean and free from water. In no case will the final estimate be prepared until the Contractor has complied with all the requirements set forth and the Engineer has made his final inspection of the entire work and is satisfied that the entire work is properly and satisfactorily constructed in accordance with the requirements of the Contract Documents.

SECTION 6

G-6.01 GENERAL

All false work, scaffolding, ladders, hoistways, braces, pumping plants, shields, trestles, roadways, sheeting, centering forms, barricades, drains, flumes, and the like, any of which may be needed in the construction of any part of the work and which are not herein described or specified in detail, must be furnished, maintained and removed by the Contractor, and he shall be responsible for the safety and efficiency of such works and for any damages that may result from their failure or from their improper construction, maintenance, or operation.

G-6.02 PUBLIC ACCESS

At all points in the work where public access to any building, house, place of business, public road, or sidewalk would be obstructed by any action of the Contractor in executing the work required by this Contract, the Contractor shall provide such temporary structure, bridges or roadway as may be necessary to maintain public access at all times. At least one lane for vehicular traffic shall be maintained in streets in which the Contractor is working. Street closure permits are required from the Department of Public Works.

The Contractor shall provide suitable temporary bridges, as directed by the Engineer, at street intersections when necessary for the maintenance of vehicular and pedestrian traffic.

Prior to temporarily cutting of access to driveways and garages, the Contractor shall give twelve (12) hours notice to affected property owners. Interruptions to use of private driveways shall be kept to a minimum.

G-6.03 CONTRACTOR'S FIELD OFFICE

The Contractor shall erect, furnish and maintain a field office with a telephone at the site during the entire period of construction. He or an authorized agent shall be present at this office at all times while his work is in progress. Readily accessible copies of both the Contract Documents and the latest approved working drawings shall be kept at this field office.

G-6.04 TEMPORARY FENCE

If, during the course of the work, it is necessary to remove or disturb any fence or part thereof, the Contractor shall, at his own expense, if so ordered by the Engineer, provide a suitable temporary fence which shall be maintained until the permanent fence is replaced. The Engineer shall be solely responsible for the determination of the necessity for providing a temporary fence and the type of temporary fence to be used.

G-6.05 RESPONSIBILITY FOR TEMPORARY STRUCTURES

In accepting the Contract, the Contractor assumes full responsibility for the sufficiency and safety of all temporary structures or work and for any damage which may result from their failure or their improper construction, maintenance, or operation and will indemnify and save harmless the City from

all claims, suits or actions and damages or costs of every description arising by reason of failure to comply with the above provisions.

SECTION 7 TEMPORARY SERVICES

G-7.01 WATER

The Contractor shall provide the necessary water supply at his own expense. He shall, if necessary, provide and lay necessary waterlines from existing mains to the place of using, shall secure all necessary permits and pay for all taps to water mains or hydrants and for all water used at the established rates.

G-7.02 LIGHT AND POWER

The Contractor shall provide, at his own expense, temporary lighting and power facilities required for the proper prosecution and inspection of the work. If, in the opinion of the Engineer, these facilities are inadequate, the Contractor will not be permitted to proceed with any portion of the work affected thereby.

G-7.03 SANITARY REGULATIONS

The Contractor shall prohibit and prevent the committing of nuisances on the site of the work or on adjoining property and shall discharge any employee who violates this rule.

Ample washrooms and toilet facilities and a drinking water supply shall be furnished and maintained in strict conformity with the law by the Contractor for use by his employees.

G-7.04 ACCIDENT PREVENTION

Precautions shall be exercised at all times for the protection of persons and property. The safety provisions of applicable laws, building and construction codes shall be observed. The Contractor shall comply with the U. S. Department of Labor Safety and Health Regulations for construction promulgated under the Occupational Safety and Health Act of 1970 (PL 91-596), and under Section 107 of the Contract Work. Hours and Safety Standards Act (PL 91-54), except where state and local safety standards exceed the federal requirements and except where state safety standards have been approved by the Secretary of Labor in accordance with provisions of the Occupational Safety and Health Act.

G-7.05 FIRST AID

The Contractor shall keep upon the site, at each location where work is in progress, a completely equipped first aid kit and shall provide ready access thereto at all times when men are employed on the work.

G-7.06 HEATING

The Contractor shall provide temporary heat, at his own expense, whenever required on account of work being carried on during cold weather and to prevent freezing of water pipes and other damage to the work.

SECTION 8

LINES AND GRADES

G-8.01 GENERAL

All work done under this Contract shall be constructed in accordance with the lines and grades shown on the Plans, or as given by the Engineer. The full responsibility for keeping alignment and grade shall rest upon the Contractor.

The Engineer will establish bench marks and base line controlling points. Reference remarks for lines and grades as the work progresses will be located to cause as little inconvenience to the prosecution of the work as possible. The Contractor shall so place excavation and other materials as to cause no inconvenience in the use of the reference marks provided. He shall remove any obstructions placed by him contrary to this provision.

G-8.02 SURVEYS

The Contractor shall furnish and maintain, at his own expense, stakes and other such materials, and give such assistance, including qualified helpers, as may be required by the Engineer for setting reference marks. The Contractor shall check such reference marks by such means as he may deem necessary and, before using them, shall call the Engineer's attention to any inaccuracies. The Contractor shall, at his own expense, establish all working or construction lines and grades as required from the reference marks set by the Engineer, and shall be solely responsible for the accuracy thereof. He shall, however, be subject to the check and review of the Engineer.

The Contractor shall keep the Engineer informed a reasonable time in advance as to his need for line and grade reference marks, in order that they may be furnished and all necessary measurements made for record and payment with the minimum of inconvenience to the Engineer or of delay to the Contractor.

It is the intention not to delay the work for the establishment of reference marks but, when necessary, working operations shall be suspended for such reasonable time as the Engineer may require for this purpose.

G-8.03 SAFEGUARDING MARKS

The Contractor shall safeguard all points, stakes, grade marks, monuments and bench marks made or established on the work, bear the cost of reestablishing them if disturbed, and bear the entire expense of rectifying work improperly installed due to not maintaining or protecting or to removing without authorization such established points, stakes and marks.

The Contractor shall safeguard all existing and known property corners, monuments and marks adjacent to but not related to the work and, if required, shall bear the cost of reestablishing them if disturbed or destroyed.

G-8.04 DATUM PLANE

All elevations indicated or specified refer to the Mean Sea Level Datum of the U.S.C. & G.S. (N.O.S.) which is 0.80 feet above the Mean Low Water Datum of the U. S. Army

Corps of Engineers.

SECTION 9 ADJACENT STRUCTURES AND LANDSCAPING

G-9.01 RESPONSIBILITY

The responsibility for removal, replacement, relocation, repair, rebuilding or protection of all public utility installations, including poles, tracks, pipes, wires, conduits, house service connections, vaults, manholes, sewers, traffic control and fire alarm signal circuit installations and other appurtenances and facilities shall be in accordance with G-1.02 and G-1.03.

The Contractor shall also be entirely responsible and liable for all damage or injury as a result of his operations to all other adjacent public and private property, structures of any kind and appurtenances thereto met with during the progress of the work. The cost of protection, replacement in their original locations and conditions or payment of damages for injuries to such adjacent public and private property and structures affected by the work, whether or not shown on the Plans, and the removal, relocation, and reconstruction of such items called for on the Plans or specified shall be included in the various Contract Items and no separate payment will be made therefor. Where such public and private property, structures of any kind and appurtenances thereto are not shown on the Plans and when, in the opinion of the Engineer, removal or relocation and reconstruction is necessary to avoid interference with the work, payment therefor will be made as provided for extra work in Article 7.02 of the Agreement.

G-9.02 PROTECTION OF TREES

All trees and shrubs shall be adequately protected by the Contractor with boxes or otherwise and, within the City of Tampa, in accordance with ordinances governing the protection of trees. No excavated materials shall be placed so as to injure such trees or shrubs. Trees or shrubs destroyed by negligence of the Contractor or his employees shall be replaced by him with new stock of similar size and age, at the proper season, and at the sole expense of the Contractor.

Beneath trees or other surface structures, where possible, pipelines may be built in short tunnels, backfilled with excavated materials, except as otherwise specified, or the trees or structures carefully supported and protected from damage.

The City may order the Contractor, for the convenience of the City, to remove trees along the line of trench excavation. If so ordered, the City will obtain any permits required for removal of trees. Such tree removal ordered shall be paid for under the appropriate Contract Items.

G-9.03 LAWN AREAS

Lawn areas shall be left in as good condition as before the starting of the work. Where sod is to be removed, it shall be carefully removed and later replaced, or the area where sod has been removed shall be restored with new sod in the

manner described in the Technical Specifications section.

G-9.04 RESTORATION OF FENCES

Any fence, or part thereof, that is damaged or removed during the course of the work shall be replaced or repaired by the Contractor and shall be left in as good a condition as before the starting of the work. The manner in which the fence is repaired or replaced and the materials used in such work shall be subject to the approval of the Engineer. The cost of all labor, materials, equipment, and work for the replacement or repair of any fence shall be deemed included in the appropriate Contract Item or Items, or if no specific Item is provided therefor, as part of the overhead cost of the work, and no additional payment will be made therefor.

SECTION 10 PROTECTION OF WORK AND PUBLIC

G-10.01 TRAFFIC REGULATIONS

The Contractor shall arrange his work to comply with Article G-6.02. The work shall be done with the least possible inconvenience to the public and to that end the work may be confined by the Engineer to one block at a time.

G-10.02 BARRIERS AND LIGHTS

During the prosecution of the work, the Contractor shall put up and maintain at all times such barriers, and lights, as will effectually prevent accidents. The Contractor shall provide suitable barricades, red lights, "danger" or "caution" or "street closed" signs and watchmen at all places where the work causes obstructions to the normal traffic or constitutes in any way a hazard to the public. Such barriers and signs shall be constructed to State of Florida Department of Transportation standards and placed as recommended by the Traffic Division of the City's Department of Public Works.

No open fires will be permitted.

G-10.03 SMOKE PREVENTIONS

The Contractor shall use hard coal, coke, oil or gas as fuel for equipment generating steam. A strict compliance with ordinances regulating the production and emission of smoke will be required.

G-10.04 NOISE

The Contractor shall eliminate noise to as great an extent as practicable at all times. Air compressing plants shall be equipped with silencers and the exhaust of all gasoline motors or other power equipment shall be provided with mufflers. In the vicinity of hospitals and schools, special care shall be used to avoid noise or other nuisances. The Contractor shall strictly observe all local regulations and ordinances covering noise control.

Except in the event of an emergency, no work shall be done between the hours of 7:00 p.m. and 7:00 a.m., or on Sundays.

If the proper and efficient prosecution of the work requires operations during the night, the written permission of the Engineer shall be obtained before starting such items of the work.

**SECTION 13
CLEANING**

G-10.05 ACCESS TO PUBLIC SERVICES

Neither the materials excavated nor the materials or plant used in the construction of the work shall be so placed as to prevent free access to all fire hydrants, valves or manholes.

G-10.06 DUST PREVENTION

The Contractor shall prevent dust nuisance from his operations or from traffic by keeping the streets sprinkled with water at all times.

G-10.07 PRIVATE PROPERTY

The Contractor shall so conduct the work that no equipment, material, or debris will be placed or allowed to fall upon private property in the vicinity of the work unless he shall have obtained the owner's written consent thereto and shall have shown this consent to the Engineer.

**SECTION 11
SLEEVES AND INSERTS**

G-11.01 COORDINATION

When the Contract requires the placing of conduits, saddles, boxes, cabinets, sleeves, inserts, foundation bolts, anchors, and other like work in floors, roofs, or walls of buildings and structures, they shall be promptly installed in conformity with the construction program. The Contractor who erects the floors, roofs, and walls shall facilitate such work by fully cooperating with the Contractors responsible for installing such appurtenances. The Contractor responsible for installing such appurtenances shall arrange the work in strict conformity with the construction schedule and avoid interference with the work of other contractors.

G-11.02 OPENINGS TO BE PROVIDED

In the event timely delivery of sleeves and other materials cannot be made and to avoid delay, the affected Contractor may arrange to have boxes or other forms set at the locations where the appurtenances are to pass through or into the floors, roofs, walls, or other work. Upon the subsequent installation of these appurtenances, the Contractor erecting the structure shall fill around them with materials as required by the Contract. The necessary expenditures incurred for the boxing out and filling in shall be borne by the Contractor or Contractors required to furnish the sleeves and inserts. Formed openings and later installation of sleeves will not be permitted at locations subject to hydrostatic pressure.

**SECTION 12
CUTTING AND PATCHING**

G-12.01 GENERAL

The Contractor shall do all cutting, fitting, or patching of his portion of the work that may be required to make the several parts thereof join and coordinate in a manner satisfactory to the Engineer and in accordance with the Plans and Specifications. The work must be done by competent workmen skilled in the trade required by the restoration.

G-13.01 DURING CONSTRUCTION

During construction of the work, the Contractor shall, at all times, keep the site of the work and adjacent premises as free from material, debris, and rubbish as is practicable and shall remove the same from any portion of the site if, in the opinion of the Engineer, such material, debris, or rubbish constitutes a nuisance or is objectionable.

The Contractor shall remove from the site all of his surplus materials and temporary structures when no further need therefor develops.

G-13.02 FINAL CLEANING

At the conclusion of the work, all erection plant, tools, temporary structures and materials belonging to the Contractor shall be promptly taken away, and he shall remove and promptly dispose of all water, dirt, rubbish or any other foreign substances.

The Contractor shall thoroughly clean all equipment and materials installed by him and shall deliver such materials and equipment undamaged in a bright, clean, polished, and new appearing condition.

**SECTION 14
MISCELLANEOUS**

G-14.01 PROTECTION AGAINST SILTATION AND BANK EROSION

The Contractor shall arrange his operations to minimize siltation and bank erosion on construction sites and on existing or proposed watercourses and drainage ditches.

G-14.02 EXISTING FACILITIES

The work shall be so conducted to maintain existing facilities in operation insofar as is possible. Work shall be scheduled to minimize bypassing during construction. Requirements and schedules of operations for maintaining existing facilities in service during construction shall be as described in the Special Provisions.

G-14.03 USE OF CHEMICALS

All chemicals used during project construction or furnished for project operation, whether herbicide, pesticide, disinfectant, polymer, reactant or of other classification, must show approval of either EPA or USDA. Use of all such chemicals and disposal of residues shall be in strict conformance with instructions.

SPECIFIC PROVISIONS

SPT-1.01 MOBILITY DEPARTMENT TRANSPORTATION DIVISION (TSS) TECHNICAL SPECIFICATIONS:

Division II & III of the Florida Department of Transportation Standard Specifications, July 2022 Edition, with revisions provided in the Technical Specification Special Provisions.

The following hierarchy of the contract documents shall apply:

The TSS Technical Specifications shall govern, except as noted herein.

In the case of apparent conflict with the project plans, the Specific Provisions shall govern.

SPT-2.01 BID ITEMS:

It is the intent of these Contract Documents that any items of work and all costs for which compensation is not directly provided by a bid item but are incidental to various project items of work, shall be prorated and included in the bid item for which they are required. Failure of the Contractor to follow this procedure shall be basis for rejection of its bid.

SPT-2.02 WORK DIRECTIVE CHANGE:

A Work Directive Change is a written directive to the Contractor, issued on or after the date of the execution of the Agreement, and signed by the Engineer on behalf of the City, ordering an addition, deletion or revision in the work, or responding to an emergency. A Work Directive Change will not change the contract price or the time for completion, but is evidence that the parties expect that the change directed or documented by a Work Directive Change will be incorporated in a subsequently issued Change Order following negotiations by the parties as to its effect, if any, on the contract price or the time of completion.

Without invalidating the Agreement, certain additions, deletions or revisions in the work may, at any time or from time to time, be authorized by a Change Order or a Work Directive Change. Upon receipt of any such document, the Contractor shall promptly proceed with the work involved.

SPT-2.03 LINES AND GRADES:

The General Provisions Section G-8.01 and G-8.02 are revised to read as follows:

G-8.01 General:

All work done under this contract shall be constructed in accordance with the lines and grades as shown on the plans or as directed by the Engineer. The full responsibility for keeping alignment and grade shall rest upon the Contractor.

The Engineer will establish Bench Marks and baseline controlling points only.

G-8.02 Surveys:

The Contractor shall furnish and maintain, with no additional payment, stakes and other such material as may be required for setting reference marks; and shall, with no additional payment, establish all working or construction lines and grades as required from the reference marks set by a Florida Registered Professional Surveyor and Mapper hired and/or employed by the Engineer, and shall be solely responsible for the accuracy thereof. The Contractor shall, however, be subject to the check and review of a Florida Registered Professional Surveyor and Mapper hired and/or employed by the Engineer the Engineer.

Pay items requiring survey information, such as embankment or excavation, shall be documented by of a Florida Registered Professional Surveyor and Mapper. In addition, plotted cross sections and quantity computations must be supplied and certified. All surveys shall be performed using electronic data collection for data acquisition. All drawings shall be submitted in the most current version of AutoCad being used by the COT department requiring the survey. All surveys must meet the Minimum Technical Standards set forth by the Florida Board of Professional Surveyors and Mappers in Chapter 5J-17, Florida Administrative Code, pursuant to Section 472.027, Florida Statutes. All surveys must also meet any standards or specifications which may be included as part of the scope of contract.

SPT-2.04 REQUIREMENTS FOR CONTROL OF THE WORK:

Prior to the start of the work included in this contract, a Preconstruction Conference will be held by the Engineer to be attended by the Contractor and representatives of the various utilities and others for the purpose of establishing a schedule of operations which will coordinate the work to be done under this contract with all related work to be done by others within the limits of the project. The Contractor shall be prepared for this meeting and shall present a comprehensive construction schedule for all items of work to be accomplished, which will be used as the basis for the development of an overall operational schedule and a list of subcontractors and material suppliers to be used on this work.

All items of work in this contract shall be coordinated so that progress on each related work item will be continuous from week to week. The progress of the work will be reviewed by the Engineer at the end of each week, and if the progress on any item of work during that week is found to be unsatisfactory, the Contractor shall be required to adjust the rate of progress on that item or other items as directed by the Engineer.

The Contractor shall conduct operations in such a manner as will result in the minimum of inconvenience to occupants of adjacent homes and business establishments and shall provide temporary access as directed or as conditions in any particular location may require.

Access to adjacent residential, public and commercial properties shall be provided at all times during the contract period.

The Contractor shall restore to its previous condition as directed by the Engineer any private property, City property, or utilities damaged by its construction. No payment shall be made to the Contractor for any required restoration of private property, City property or utilities, unless otherwise noted.

SPT-2.05 REFERENCE STAKES:

Add the following paragraph to General Provision Section G-8.03:

The Contractor shall, with no additional payment, furnish and install reference stakes at all even and half-stations along the project survey baseline.

These stakes shall be maintained for the duration of construction for the purpose of the Engineer's reference.

SPT-2.06 CONTRACTOR'S WEEKLY SCHEDULE:

In order that the Contract Administration personnel may be advised of the work to be performed, the Contractor may be required to submit weekly to the Engineer of its designated representative a schedule indicating the proposed work plan for the forthcoming week. Such shall be delivered to DT&SS not later than Friday preceding the work plan week unless other arrangements have been made for this submittal.

SPT-2.07 MONTHLY CONSTRUCTION ESTIMATES AND RELEASE OF LIEN:

The Contractor shall prepare on or about the first day of each month an estimate of the work completed in the preceding month by the Contractor. Any disputed quantities shall be adjusted as directed by the Engineer prior to each partial payment, as provided for in Article 10.05 of the Agreement.

Certification that all subcontractors have been paid for the previous month's work shall be submitted with each partial payment request on forms provided by the Engineer.

An update of the overall project schedule shall be submitted with each partial payment request.

SPT-2.08 CONTRACTOR'S REPRESENTATIVE:

Add to Article 8.02 of the Agreement:

"The Contractor shall submit in writing to the Construction Engineer the name of its duly authorized representative who will be present on the job during all work activities and is authorized to make decisions for the Contractor. Any change in the contractor's representative shall require written notification to the Construction Engineer prior to such change".

SPT-2.09 NOTICE AND SERVICE THEREOF:

All notices, which shall include demands, instruction, requests, approvals, and claims, shall be in writing.

Any notice to or demand upon the Contractor shall be sufficiently given if delivered to the Contractor's representative at the construction site or to the office of the Contractor specified in the bid (or to such other offices as the Contractor may, from time to time, designate to the City in writing), or if deposited in the United States mail in a sealed, postage-prepaid envelope, or delivered, with charges prepaid, to any telegraph company for transmission, in each case addressed to such office.

All notices required to be delivered to the City shall, unless otherwise specified in writing to the Contractor, be delivered to the Engineer, 3806 E. 26th Avenue, Tampa, Florida 33605, and any notice to or demand upon the City shall be sufficiently in the United States mail in a sealed, postage-prepaid envelope, or delivered with charges prepaid to any telegraph company for transmission, in each case addressed to said Engineer or to such other representative of the City or to such other address as the City may subsequently specify in writing to the Contractor or to its representative at the construction site for such purposes.

Any such notice or demand shall be deemed to have been given or made as of the time of actual delivery or (in the case of mailing) when the same should have been received in due course of post or (in the case of telegram) at the time of actual receipt, as the case may be.

SPT-2.10 CONTRACTOR'S FIELD OFFICE:

The Contractor will not be required to provide a Contractor's field office.

The Contractor, however, shall have Contract Documents, the latest approved working drawings, standard drawings and a representative of the Contractor available at the site during regular working days.

SPT-2.11 ENGINEERING'S FIELD OFFICE:

An Engineering field office shall not be required for this project.

A functional, portable cellular telephone and separate lockable sanitary facilities shall be provided to the Engineer for use throughout the duration of the project.

All costs associated with the cellular telephone (local calls only) and sanitary facilities shall be borne by the Contractor. No separate payment shall be made for these services.

SPT-2.12 DAMAGE TO ADJACENT STREETS:

Any streets (including detour routes) consisting of travel lanes, curbs, gutters and shoulders, outside the project area (not designated for construction), which are determined by the Engineer to have been damaged due to negligent construction related operations and/or equipment, shall be restored by the Contractor to its original or better condition without any cost to the City and to the satisfaction of the Engineer.

SPT-2.13 PROJECT PHOTOGRAPHS:

The Contractor will not be required to furnish photographs of the project; however, the Engineer may or may not take photographs of the area immediately prior to and after completion of the construction for record and information. To assure that there will not be any conflict with this photography, the Contractor shall not perform clearing operations or actions which will disturb any street or area within the project until the Engineer has been advised thereof and has had adequate opportunity to perform the desired photography.

SPT-2.14 PRECONSTRUCTION VIDEO:

Prior to commencing work, the Contractor shall submit to the Engineer for approval, a DVD containing a continuous color video recording including complete coverage of pre-construction conditions of all surface features within the construction's zone of influence, (including detour routes) simultaneously produced audio commentary and electronic display of time and date. The video recording shall be sufficient to fulfill the technical and forensic requirements of the project and provide continuous unedited coverage, establishing locations and viewer orientation with clear, bright, steady and sharp video images with accurate colors free of distortion or other imperfections. The DVD must be accompanied by a detailed log of its contents including date, locations, video counter numbers and features. No work shall be allowed until the completed DVD and log are approved by the Engineer.

The costs associated with preparing the project's preconstruction video shall be included in the contract price for Mobilization.

SPT-2.15 PROJECT CLEAN-UP:

Clean-up on this project is extremely important and the Contractor will be responsible for keeping the construction site neat and clean with debris being removed regularly as the work progresses.

If project cleanliness and/or dust control reaches an unacceptable level in the opinion of the Engineer, the Engineer will notify the Contractor in writing. If the Contractor does not act to correct the situation within 4 hours in the case of dust control or within 24 hours in the case of general cleanliness, the Engineer may call upon outside forces to provide the appropriate services. Cost of all such activities shall be charged to the Contractor via contract change order.

SPT-2.16 CITY PERMITS:

The Contractor shall be responsible for obtaining all applicable City permits for this project. These can include but may not be limited to: Right-of-way permit(s), tree removal/site clearing permit(s), and drainage/earthwork permit(s). The Contractor shall supply any required plans or other information to the issuing department.

The time required to prepare, submit, review, and issue the permits shall be included in the contract time and no payment shall be made for any delay incurred by this process.

Cost for obtaining City permits shall be included in the lump sum cost for mobilization (Item No. 101-1), and no separate payment shall be made. Right-of-way permit fee shall be waived by the City.

All subcontractors working on the project shall obtain their own, separate permits as above.

SPT-2.17 AS-BUILT PLANS:

The Contractor shall provide the Engineer with "As-Built" plans, as follows:

1. All As-Built information shall be annotated by a Florida Registered Professional Surveyor and Mapper on a separate layer of each AutoCAD drawing file as provided on a disk by the City. Annotation of the new drawing files shall be in accordance with City of Tampa TSSdrafting standards, as well as the Minimum Technical Standards set forth by the Florida Board of Professional Surveyors and Mappers in Chapter 5J-17 of the Florida Administrative Code, pursuant to Section 472.027, Florida Statutes. Settings shall be as follows: Color: CYAN, Linetype: CONTINUOUS, Font: ROMANS, Layer Name: AS-BUILT, AutoCAD Menu Name: ACAD.MNU, and File Format: AUTOCAD latest version.
2. All surveys shall be completed and certified by a Florida Registered Professional Surveyor and Mapper hired and/or employed by the Contractor, and shall be in accordance with the standards of practice set forth by the Florida Board of Professional Surveyors and Mappers in Chapter 5J-17 of the Florida Administrative Code, pursuant to Section 472.027, Florida Statutes. Survey data shall be submitted as an electronic data file in AutoCad latest version. The Contractor shall also include as supporting data the ASCII files of digital raw survey data, closure reports, adjustment reports, and/or copies of any hand written field notes or sketches.
3. "As-Built", or "Record", surveys, as may be required by contract, or agreement, shall consist of survey data collected on all constructed improvements, so they may be compared to and contrasted with the design plans and/or construction drawings. The annotated disk shall delineate all changes and deviations to the planned improvements within the project limits, to include, but not be limited to, pavement, curb & gutter, sidewalk, driveways, inlets, manholes, all piping, inverts, ditches, ponds, valves, hydrants, water meters, signalization, hand holes, signing & pavement marking, landscaping, and irrigation. All changes and deviations shall be delineated by Station-Offset and vertical alignment values and shall be clearly shown on the drawing files.
3. The Contractor shall comply with the above requirements and shall submit one check print set of the plans at the same scale as the construction plans, and all the supporting survey data files, to the Engineer for review within three weeks of substantial completion of the project. Final payment for the project shall not be made until the As-Built information is received for review, any corrections are made, and approval granted by the Engineer. Upon approval, the Contractor shall provide the final As-Built drawings on the disk, at the same scale as the construction plans. These files shall be AutoCad Drawings or AutoCad Design Web Format and Adobe PDF

The cost for this work shall be included in the contract price for Mobilization and no separate payment shall be made for meeting the above As-Built requirements.

SPT-3.01 STREET CLOSURE AND MAINTENANCE OF TRAFFIC:

A City of Tampa permit for construction and maintenance operations within public Rights of Way will be required for every street, lane, or sidewalk closure within City of Tampa Rights of Way.

These permits will establish the minimum requirements for the closure related to number of lanes and/or time of day lanes or street may be closed above what is show in the plans. The Contractor shall adhere to the requirements as described in the permit(s).

The Contractor shall furnish and maintain all necessary signs, pavement markings, barricades, lights, and flagmen necessary to control all vehicular and pedestrian traffic and provide for safety of the public, all in compliance with the current Florida Department of Transportation Roadway and Traffic Design Standards and the FHWA Manual on Uniform Traffic Control Devices.

The Contractor shall observe traffic movements through the work site and inspect all traffic control devices on a regular basis to ensure that all devices are properly installed and functioning as intended.

In cases of closure for street, lane, or sidewalk on the City of Tampa Functionally Classified Network (collectors, minor arterials, and principal arterials), including all State Roads, the Contractor shall provide a maintenance of traffic plan to the City of Tampa, Transportation Division. This plan shall be provided at least seventy-two hours in advance of the closure (excluding weekends) and shall contain the following:

1. Proposed detour routes.
2. Signing of the complete construction area and detour routes.

Advance notice information signs advising the public of scheduled closure of major roadways and/or information signs advising the public of points of closure and detour routes may be required by the Engineer and will be installed at the Contractor's expense.

Payment shall be full compensation for all work, equipment, materials, tools, labor and any incidentals required to maintain safe traffic routes past the work site.

Payment shall be made under

Item No. 102-1 Maintenance of Traffic L.S.

SPT-3.02 TRAFFIC INFORMATION SIGNS:

The Contractor's attention is directed to Section 10 of the General Provisions, PROTECTION OF WORK AND PUBLIC, and to the consideration therein for providing informative signs indicating the street closures. It is the purpose of such requirements to adequately inform residents and the general public of the closure thereby creating better understanding and relations during the construction.

Street closure signs shall conform to the configuration and dimensions shown on page SIGN-2 which is hereby made part of these specifications.

SPT-3.03 PROJECT SIGN:

The Contractor shall furnish 2 project sign(s) which shall conform to the general configuration and dimensions as per page SIGN-1 which is made a part of these specifications. The sign(s) shall be maintained in good condition until the completion of the project, and shall be located as instructed by the Construction Engineer.

The cost of furnishing and maintaining the signs shall be included in the various contract items and no additional compensation shall be made.

SPT-3.04 TEMPORARY SIGNALIZATION:

The Contractor shall furnish all labor, materials and equipment required to provide and maintain operation of temporary signalization during all phases of construction until permanent signalization is installed and functioning properly. If a temporary communications interconnect is required, this will be stated on the signal plans.

The work includes all excavation, backfill, sheeting, shoring, bracing; installation of wood signal poles, guy wiring, signal heads and connecting hardware, span wire, messenger wire, signal cable, electrical service, wire and service attachment, controller and pole mounted cabinet; relocation of signal equipment during construction phasing; and all other work and hardware incidental to providing and maintaining the operation of temporary signalization.

SPT-3.05 NIGHT WORK:

If the Contractor wishes to perform night work, he shall notify the Engineer 72 hours in advance and all night work shall be performed in accordance with the following requirements:

During active nighttime operations, furnish, place and maintain lighting sufficient to permit proper workmanship and inspection. Use lighting with 5 ft-cd minimum intensity. Arrange the lighting to prevent interference with traffic or produce undue glare to property owners. Operate such lighting only during active nighttime construction activities. Provide a light meter to demonstrate that the minimum light intensity is being maintained.

Lighting may be accomplished by the use of portable floodlights, standard equipment lights, existing street lights, temporary street lights, or other lighting methods approved by the Engineer.

Submit a lighting plan at the Preconstruction Conference for review and acceptance by the Engineer. Submit the plan on standard size plan sheets (not larger than 24 by 36 inch), and on a scale of either 100 or 50 feet to 1 inch. Do not start night work prior to the Engineer's acceptance of the lighting plan.

During active nighttime operations, furnish, place and maintain variable message signs to alert approaching motorists of lighted construction zones ahead. Operate the variable message signs only during active construction activities. Include compensation for lighting for night work in the Contract prices for the various items of the Contract. Take ownership of all lighting equipment for night work.

No additional payment shall be made for night work required by the project plans or specifications.

SPT-3.06 TEMPORARY TRAFFIC STRIPING: Signalized intersections, school crossings, and four-way stop intersections shall receive special attention with temporary markings. Contractor shall be responsible for the striping plans during the project. Temporary traffic striping used by the Contractor on surfaces, which will remain exposed roadway (final resurfacing course or friction course), shall be painted per FDOT Standard Specifications for Road & Bridges, 2018 Edition, Section 710, unless an alternative is approved by the City.

All markings applied shall be in accordance with the Manual on Uniform Traffic Control Devices and in the final configuration as designed. The Engineer will provide a striping plan if new markings are to be installed to reconfigure the layout of the road. If no striping plan is available, the Contractor will re-install existing markings. Temporary reflective markers (RPM's) can be used if approved by the Engineer in writing. Paint striping shall attain an initial retro-reflectivity of at least 450 mcd/lx.m² and 350 mcd/lx.m² for both White and Yellow striping, respectively.

SPT-4.01 DENSITY REQUIREMENTS:

The subgrade, subbase and base densities shall be 98% of the Modified Proctor for all vehicular travel ways. The

density requirements for asphaltic concrete and soil cement shall be 96% of the Laboratory Standard Proctor. All other locations shall attain densities of 98% of the Modified Proctor.

SPT-4.02 STABILIZATION:

Type "C" stabilization, 12" thick shall obtain a minimum Florida Bearing Value (FBV) of 75 p.s.i.

SPT-4.03 SOIL BORING INFORMATION: - Not Applicable

SPT-4.04 TEMPORARY STOCKPILING:

For temporary stockpiling of the excavated material within project limits (and anywhere within City limits) the Contractor shall follow the following procedure.

Public Right of Way

- a. The Contractor will not be allowed to stockpile suitable, excavated material within right-of-way for a period in excess of 30 calendar days. Unsuitable excavated material shall not be stockpiled within public right-of-way for a period in excess of 7 calendar days.

Location other than Public Right-of-Way

- b. The Contractor shall:
 1. Obtain the permission (in writing) from the owner of the property where stockpiling is desired.
 2. At its own expense present the above letter and a contour plan of the site to the DT&SS Construction Engineer for approval of stockpiling site.
 3. At the conclusion of the stockpiling activity, the Contractor shall obtain a signed letter of release from the property owner that he/she is completely satisfied with the stockpiling operation and with the restoration of their property. A copy of the letter shall be furnished to the Engineer.

The time periods of stockpiling shall be specified by the Contractor in writing.

Upon removal of stockpiled material, the Contractor shall clean up and grade the site to its original contours and conditions.

The City of Tampa shall not be a party to any agreement between the Contractor and private property owner(s).

Regardless of the location of stockpiling, it shall be the Contractor's responsibility to make sure that stockpiling in no way constitutes a public hazard, nuisance and does not interfere with the natural surface runoff in the area.

SPT-4.05 DEWATERING:

Any dewatering related to this project will not be a separate bid item. The cost shall be included in the price of the facility being installed at that location and/or any related pay items.

SPT-4.06 COMPACTION OF SUITABLE CLAY FILL MATERIAL:

The Contractor shall have equipment available to properly compact any suitable clay fill material at no additional cost to the City.

SPT-5.01 UTILITY PROTECTION CONSIDERATIONS:

The Contractor shall protect all utilities and other facilities within and adjacent to the construction as covered in Section G- 1.03, unless a utility firm has conclusively indicated, or such is shown on the plans, that the certain adjustment, removal, reconstruction, or protection of the utility's facility will be performed by that respective utility.

The Contractor shall make every effort to protect all water mains. If the main is damaged or lost, the Contractor shall replace the affected line in strict accordance with the City of Tampa Water Department Specifications and Construction Standards, latest edition, at no extra cost to the City, and he shall assure that service is maintained at all times.

The Contractor shall make every effort to protect all sanitary sewer lines. If the main is damaged or lost, the Contractor shall replace the affected line in strict accordance with the City of Tampa Department of Sanitary Sewer Specifications and Construction Standards, latest edition, at no extra cost to the City.

It will be the Contractor's responsibility to preserve all existing sanitary sewer services without interruption during the construction of storm sewers or the repairs or reconstruction of sanitary sewers.

When the construction of storm sewers, repair or reconstruction of sanitary sewers has been completed, all temporary connections shall be removed. Sewers shall be cleaned of all settled solids.

The cost of handling sanitary sewers during construction, including cost of all labor, materials, and equipment or other items incidental to completing the job, shall be included in the contract price as bid for the contract items and no separate payment shall be made.

It will be the Contractors responsibility to preserve all existing ditches, swales, force main, gravity main, laterals, etc., and other stormwater appurtenances and facilities pertaining thereto whether owned or controlled by City, other governmental bodies or privately owned by individuals, firms or corporations.

Any temporary measures constructed shall first be approved by the Engineer. The cost of such temporary measures shall be included in the contract price bid for storm sewer items and no separate payment shall be made.

The Contractor shall furnish, install, and remove sheeting and shoring and other protective measures as may be necessary to satisfactorily accomplish the construction of this project. The cost of such sheeting and shoring and other protective measures shall be included in the unit prices as bid for the storm sewer items and no separate payment shall be made.

Compensation for steel sheeting and shoring furnished, installed and removed shall be paid for as extra work in accordance with Article 7.02, EXTRA WORK, on Page A-18 of the Tampa Agreement when approved for use by the Engineer. Such approval shall be for its use only, and the Contractor shall have full responsibility for the design, installation, and removal of the sheeting and shoring. The Contractor shall obtain the services of a registered Professional Engineer to design and certify the sheeting and shoring plans.

SPT-5.02 ADJUSTMENT OF UTILITIES AND PUBLIC SERVICE INSTALLATIONS:

Storm and sanitary sewer manhole covers, valve covers or boxes, water meter boxes, and vaults located within the limits of construction of the pavement or sidewalk area to be constructed, reconstructed or overlaid shall be relocated or adjusted by the Contractor to conform with the new pavement or sidewalk elevation as a part of the work of constructing or reconstructing the pavement or sidewalk and no separate payment will be provided therefor.

Appurtenances of other utilities will be relocated or adjusted by the utility company owning or having jurisdiction over the respective utility.

SPT-5.03 REMOVAL OR ADJUSTMENT OF PUBLIC UTILITIES:

The Contractor will make necessary arrangements with public utility owners, including the City of Tampa Water and Sanitary Sewers, for removal or adjustments of existing utilities, whether shown or not shown on the plans, where such removal or adjustment is determined by the Engineer to be essential to the performance of the required construction, provided normal construction procedures are used by the Contractor.

Relocations or adjustments requested by the Contractor on the basis of the use of a particular method of construction or a particular type of equipment shall not be considered as being essential to the construction of the project if other commonly used methods or equipment could be employed without the necessity of relocating or adjusting the utility. The Engineer will determine the responsibility for any such adjustment of utilities.

Relocations or adjustments requested for the Contractor's convenience or because of delivery of materials to the job site shall be the responsibility of and at the expense of the Contractor.

The Contractor shall be required to coordinate its activities with relocation work by the utilities. A schedule for relocation work will be presented to the Contractor at the pre-construction conference. This schedule may be adjusted to "fit" the Contractor's proposed schedule, but it will include periods during which the Contractor's ability to perform work in the relocation area will be limited, with no additional compensation.

SPT-6.01 USE OF CITY WATER SYSTEM:

The Contractor shall be responsible for obtaining and paying for a Tampa Water Department portable meter that shall be utilized when obtaining water from the City system. These costs shall be included in the various contract items and no additional compensation shall be made.

SPT-6.02 WATER MAIN CONSTRUCTION AND/OR OFFSET: Work shall be performed per the City of Tampa Water Technical Manual and Engineering Standard Details.

SPT-6.03 WATER SERVICE CONNECTIONS: Work shall be performed per the City of Tampa Water Technical Manual and Engineering Standard Details.

SPT-7.01 SANITARY SEWER CONSTRUCTION: Work shall comply with City of Tampa construction standards.

SPT-7.02 SANITARY SEWER HOUSE LATERAL EXTENSION: Work shall comply with City of Tampa construction standards.

SPT-8.01 FILLING LOW AREAS WITHIN CITY LIMITS:

The Contractor under Sec. 21-27 (Permit Requirements) of the City of Tampa Code is prohibited from filling any area public or private (except where shown on the construction plans) within the project limits or any where within the City limits without a permit.

For filling and/or grading any area, the owner of such area shall obtain a permit from the Stormwater Management Division, Department of Sanitary Sewers, City of Tampa. The owner shall submit existing and proposed contour plans of the area to be filled and the adjacent land for determination if a permit could be issued. Drainage patterns can not be altered to the detriment of neighboring property owners or public rights-of-way.

Concurrently the permit application will be reviewed by the Parks Department.

The Contractor shall not deposit any fill material within the City limits without an approved permit. A copy of the permit shall be submitted to the Engineer, by the Contractor prior to any filling or grading operation.

SPT-8.02 ENVIRONMENTAL PROTECTION:

The Contractor will be held liable for the violation of any and all environmental regulations. Violation citations carry civil penalties and in the event of willful violation, criminal penalties. The fact that the permits are issued to the City does not relieve the Contractor in any way of its environmental obligations and responsibilities.

SPT-8.03 CONFLICT STRUCTURE: Work shall comply with City of Tampa construction standards.

SPT-8.04 REINFORCED CONCRETE PIPE/BOX:

All reinforced concrete pipe, reinforced concrete arch culverts, storm drain, and sewer pipe, all reinforced concrete

elliptical pipe and all pre-cast reinforced concrete box sections shall be inspected and accepted by a testing laboratory approved by the Engineer.

Each pipe/box shall bear the stamp of acceptance of the testing laboratory and the Engineer shall be supplied with a copy of each inspection report, including a certification of "D-load", absorption test and conformance to the dimensional and all other designations of ASTM specifications. The cost of such inspection services shall be included in the unit prices for the respective pipe/box items.

Unless specified otherwise on plans, or directed by the Engineer, all storm sewer and culvert pipes shall be ASTM Class III, B wall thickness. All steel shall be grade 60.

All joints in elliptical concrete pipe and round R.C.P. shall be provided with filter fabric or concrete jacket as per F.D.O.T. Standard Plans No. 430-001 and as directed by the Engineer. Filter fabric shall be provided at all joints, except the last two joints not supported by a structure; these joints shall be provided with a concrete collar.

The cost of the filter fabric jackets and concrete collars shall be included in the unit cost of pipe. No extra payment will be paid for such jackets or collars.

All round and elliptical reinforced concrete pipe and all pre-cast concrete box sections shall be manufactured and installed without lift holes. The Contractor shall install the pipe/box with the use of slings, hooks or other methods approved by the Engineer.

All round and elliptical reinforced concrete pipe shall be manufactured without visible corrugations on the internal wall. Any pipe with visible corrugations on the internal wall shall be rejected.

SPT-8.05 CONSTRUCTION OF PAVED SUMP BETWEEN INLET AND EDGE OF PAVEMENT:

Whenever the plans indicate construction of a modified inlet, the Contractor shall construct a standard curb inlet with a concrete apron as shown in the details, the addition of the concrete apron being the only distinction between a standard inlet and a modified inlet.

If the edge of the concrete apron will be located immediately adjacent to the edge of existing asphalt pavement, and that pavement is not to be repaired or replaced as part of the construction, the Contractor shall saw cut the asphalt pavement to provide a neat clean edge and the concrete apron shall use that edge as part of the form.

If the edge of the concrete apron does not touch the edge of existing pavement, the Contractor shall construct a transitional apron, with 3:1 mitered edges, to connect the edge of the concrete apron to the edge of pavement. This transitional apron shall be constructed of the same material composition as the existing pavement.

All costs to construct the required concrete apron and any required transitional apron shall be included in the contract bid item of that modified inlet and no additional payment shall be made.

Wherever the plans indicate an inlet, either curb or grating type, to be placed outside the edge of existing pavement or curb limit so as to be in proper position for future street widening, the Contractor will be required to construct a paved sump between the edge of such existing pavement and inlet opening. The type of pavement for such sump areas shall be similar and equal to that of the adjacent roadway to which it is connected. Payment shall be made under the applicable items for street replacement.

SPT-8.06 DRAINAGE STRUCTURES:

1. All inlets and manholes shall, unless otherwise directed by the Engineer, be constructed as per design plans and applicable design standards. All manholes shall be Traffic Bearing type. It shall be the responsibility of the Contractor to assure that the designated sizes of the drainage structures meet the following criteria:
 - a. The minimum distance from the top of the opening for the highest pipe to the bottom of the top slab shall be ten inches (10"); 12"+ from top of pipe to bottom of top slab, before "stack" is used.
 - b. The minimum diameter for stacks shall be as follows:
Twenty-four inches (24") for four feet (4') heights, Thirty-six inches (36") for four feet (4') to six feet (6') heights, and Forty-eight inches (48") for heights over six feet (6').

The stacks shall be symmetrical about the openings, five inches (5") minimum wall thickness, reinforced, and keyed (unless constructed of brick) as per the appropriate FDOT standard.
 - c. The minimum distance between pipe openings shall be nine inches (9").
 - d. For four-sided structures having openings in one or more corners, individual shop drawings must be submitted for prior approval.
2. If warranted by field conditions and directed by the Engineer, the Contractor shall, at such locations, construct rectangular brick drainage structures (in place of concrete drainage structures), according to the standards specified below:

Brick construction shall be as follows:

- a. Wall thickness minimum eight inches (8") up to eight feet (8') height, unless specified otherwise.
- b. Wall thickness minimum twelve inches (12") up to twelve feet (12') height, unless specified otherwise.
- c. Brick shall be laid in 1:2 (Portland cement-sand) mortar.
- d. Before laying the bricks in mortar, the bricks shall be thoroughly sprinkled with clean water (not to saturation extent).
- e. Brick for manhole and inlet structures shall be laid in stretcher courses, with every sixth course a header course.
- f. All brick structures shall be plastered smooth inside and outside with 1/2" thick, 1:2 (Portland cement-sand) mortar.
- g. No "unsound" brick shall be used. As a test, if a light hammer blow, with the brick held lightly in hand, does not produce a uniform crisp ringing sound, the brick shall be construed to have crack(s), or otherwise unsound and shall be rejected.
- h. All bricks shall be solid clay.

3. No additional compensation shall be paid for brick structures.
4. For all types of manholes, the top and bottom slabs shall be as per applicable D.O.T. standards, even if brick is allowed to be used in the manhole walls. The following criteria shall apply to slab thicknesses and steel reinforcements:
 - a. Top and bottom slabs shall have the same thicknesses and reinforcements in any manhole structure.
 - b. The minimum slab thickness and reinforcement shall be: 8" thick and #6 bars at 6" centers both ways.
 - c. 4'x6' or larger manholes including circular manholes with inside diameter of 5.0' or larger shall have 10" thick slabs with #7 bars at 6" centers both ways.
 - d. Unless specified on the plans, four sided structures with both inside dimensions in excess of 8.0' and circular structures with inside diameter in excess of 8.0' shall not be covered by D.O.T. and the above criteria.
5. All grate inlets shall conform to the City of Tampa design standards.
6. Grates on inlets, as well as all other structures, shall be Traffic Bearing Type, unless specified otherwise, and subject to approval of the Engineer. All grate inlets shall be fitted with an approved metal frame at the top to seat the grates.
7. All Type-P manholes shall be bid at one average unit price regardless of size and shape. Similarly, all Type-J manholes will be bid at one average unit price regardless of size and shape unless indicated otherwise in the proposal.
8. Vertical support columns (one in case of Type 5 inlet) shall be constructed by the contractor, as a part of the D.O.T. Type 5 and 6 curb inlets, where and as directed by the Engineer.
9. The Contractor, if so directed by the Engineer in order to better meet site requirements, shall construct B-S-1, B-R-2, B-V-1, or B-R-1 type curb inlets in lieu of D.O.T. Type 5 and 6 curb inlets and vice-versa without additional cost to the City. P-5 and P-6 inlets shall have 3'-6" x 3'-6" substructures unless oversize pipe is to be accommodated or otherwise directed by the Engineer.

Side openings in curb and grate type inlets may be specified in the plans to meet site conditions. The Contractor shall provide such opening without any additional cost.
10. When precast drainage structures are requested as substitutions for poured in place concrete structures, Contractor shall meet the following additional requirements:
 - a. Minimum height of the base structure (manhole or inlet barrel) unless restricted by design, shall be 5'-0" before extending the structure height by another precast "barrel". The minimum height of the top (extension) precast "barrel" shall be 1'-6". "Barrel" extensions of less than 1'-6" height shall be cast in place with continuous reinforcement.
 - b. Four-side structures may be considered as an alternate to circular structures, but not the reverse.

- c. For City type curb inlets, unless specified otherwise, directed by the Engineer, or to accommodate larger pipes, the Contractor may use 3'x4' (inside dimensions) substructures. This structure shall have same slab and wall thicknesses and steel reinforcing as specified for "Type E" grate inlet.
- d. When circular structures are precast in accordance with ASTM C478, the following limitations will apply:
 - (i) Maximum inside diameter shall not exceed 96".
 - (ii) Minimum wall thickness for 42" and 48" diameter substructures shall be 6"; 7" for 72" diameter, 8" for 84" and 96" diameters.
 - (iii) Vertical reinforcement in walls shall be equal in area to the required circumferential reinforcement area. Reinforcement spacing shall not exceed 12" O.C. in either direction.
- e. The location of the pipe holes and adequate basic substructures height, unless directed otherwise by the Engineer, shall be the responsibility of the Contractor.
- f. Contractor shall submit shop drawings only as specified below:
 - (i) One each-typical for different type of structures.
 - (ii) For structures directed by the Engineer, and/or requiring change with respect to design plans, or as otherwise required by these specifications.
- g. No compensation shall be paid to the Contractor for precast drainage structures which are unusable due to site conditions or changes in plans.
- h. Provide material testing acceptance reports by a licensed private laboratory verifying:
 - (i) That the structures were constructed in accordance with detail shown on the plans and/or typical Drawings.
 - (ii) Specific reference shall be made to the exact design criteria adhered to; if more than one, identify which criteria applies to which structures.
 - (iii) Identify the project title, project number, file number, date cast, structure, plan sheet number and station.
 - (iv) Reinforcement size, spacing, amount and cover.
 - (v) Concrete placement, curing and strength.
 - (vi) The testing laboratory stamp shall be placed on each structure prior to shipment.
- 11. All manhole and inlet structures shall be set on a minimum of a six inch thick layer of compacted number 57 size coarse aggregate unless noted otherwise in the plans or specifications or unless the Engineer determines a thicker layer is required due to soil and/or water conditions.

Payment for the six inch thick layer of stone shall be included in the price of the structure. Payment for thicker layers of stone shall be from the Selected Bedding Material (Stone) pay item, if available, or as extra work.

SPT-8.07 RIP-RAP:

Bags made from synthetic fiber or material shall not be used for sand-cement rip-rap. The preferred bag material is jute.

Filter fabric shall be placed behind (adjacent to the soil) wherever rip-rap is placed.

SPT-8.08 STANDARD FOR FILTER FABRIC:

Unless specified otherwise on the plans, filter fabric shall be nonwoven fabric per F.D.O.T. Specification Sections 514 and 985. Payment for furnishing and placing the filter fabric shall be included in the contract price for the item or items to which it is incidental.

SPT-8.09 CONNECTION TO EXISTING INLET OR MANHOLE:

The Contractor shall furnish all labor, equipment and materials required to connect the proposed pipeline into existing inlet or manhole as shown on the Plans, specified and directed by the Engineer.

The work includes all excavation, dewatering, breaking into the existing structure, closing of the existing slot, removal and disposal of rubble and excess materials, installation of storm sewer pipe, sealing the voids around the pipe, backfilling, compacting, and all other work incidental to connection to existing inlet or manhole.

The cost for pipe and structure connections shall be included in the various contract items and no additional compensation shall be made.

SPT-8.10 EROSION CONTROL PLAN:

In addition to the requirements of Section 104, the Contractor shall be required to submit an erosion control plan to the Engineer at the time of the preconstruction conference. The erosion control plan shall indicate in detail all measures proposed by the Contractor to meet its erosion control obligations, including all items required to meet permitting conditions for the project. Any phasing of the erosion control plan shall also be shown.

The cost of providing, revising and updating the erosion control plan shall be included in the unit costs of the various contract items and no separate payment shall be made.

SPT-8.11 CONCRETE STRUCTURES AND CONCRETE BOX CULVERTS: Work shall comply with City of Tampa construction standards.

SPT-8.12 DRAINAGE STRUCTURE AND PIPE BEDDING:

The contractor shall furnish and install a two-foot thick foundation rock bed consisting of #57 FDOT stone under all stormwater inlets, manholes, and mitered end sections installed under this project. Foundation rock shall be fully wrapped with filter fabric.

The contractor shall furnish and install pipe bedding consisting of #57 FDOT stone or other crushed stone material as approved by the Engineer under all stormwater pipes 30 inches in diameter or greater and under all equivalently sized elliptical stormwater pipes. Bedding material shall extend below and beside the pipe as shown on the plans if applicable. Bedding material shall be fully wrapped with filter fabric.

Payment shall be full compensation for all materials, equipment, labor, and any incidentals necessary for placement of the foundation rock and/or pipe bedding. Payment for the furnishing and installation of filter fabric shall be included in the unit price bid for bedding material.

SPT-9.01 EXISTING SIDEWALKS, DRIVEWAYS AND PARKING AREAS:

The Contractor shall meet existing sidewalks, driveways and parking areas (concrete or asphalt) when possible with the proposed street replacement. At locations where existing sidewalks and driveways are not at the same elevations as the new grades, the Contractor may be required to reconstruct a portion of the sidewalk or driveway as directed by the Engineer. (When existing driveway is of asphalt type, a base of 6" thickness shall be constructed with a 1" thick asphaltic concrete surface course.)

Payment will be as per the applicable contract unit bid prices for concrete sidewalk 4", concrete driveway 6", 6" base, and asphaltic surface course. There will be no payment if existing sidewalks or driveways must be reconstructed due to negligence of the Contractor.

SPT-9.02 PRIME/TACK COAT:

The bid unit prices for Asphaltic Concrete shall include the bituminous material for prime/tack coat.

SPT-9.03 PAVEMENT REPLACEMENT AND TOTAL RESTORATION: - Not Applicable

SPT-9.04 CONCRETE CURB OR CURB-AND-GUTTER:

Expansion joints in concrete curb or curb-and-gutter shall be placed at all inlets, radius points, horizontal and vertical points of intersection (P.I.'s), and as otherwise directed by the Engineer. They shall be located at intervals of 100 feet between other expansion joints or ends of a run.

SPT-9.05 ASPHALT LEVELING COURSE:

The Contractor shall provide Superpave Asphaltic Concrete Leveling as directed by the Engineer. This item shall be used on an as-needed or contingency bases, and shall be furnished and installed by the Contractor at a unit price per ton.

SPT-9.06 PAVEMENT MIX DESIGNS:

The Contractor shall submit to the Engineer a mix design which has been approved by the FDOT within the previous twelve months, and which has been assigned and FDOT Quality Assurance Number, for each type of asphaltic pavement to be used on the project. The Engineer may, at its discretion, approve mix designed not meeting the above stipulations.

SPT-9.07 USE OF RECLAIMED ASPHALT: - Not Applicable

SPT-9.09 PEDESTRIAN RAMPS WITH DETECTABLE WARNINGS

All pedestrian ramps constructed in new sidewalk under Section 522 of the FDOT Technical Specifications shall comply with F.D.O.T. Standard Plans No. 522-002 and 522-001, except that Detectable Warning Strips, a.k.a., domes, for District Seven Construction and Maintenance should be per the FDOT Approved Product List, Specification Number 527 and attached to the concrete with bolt/screw. Detectable warnings shall be red brick in color only. Payment for pedestrian ramps shall be included in the sidewalk concrete pay item. Detectable warnings have a separate pay item.

SPT-10.01 GRASSING AND/OR SODDING:

Lawn road shoulders, and all areas that do not have well established grass at the time of construction and are disturbed during construction may be grassed, as directed by the Engineer. All areas shall be properly prepared by removal of construction debris and rocks, and soil preparation and fertilization or placement of topsoil as directed by the Engineer. Lawn, road shoulders, and other locations where construction shall occur that are well maintained and show healthy grass at the time of construction, or where otherwise directed by the Engineer, shall be sodded with either Pensacola or Argentine Bahia Type or St. Augustine type sod as applicable. Disturbed areas to be landscaped or sodded shall be restored within fourteen days of substantial completion of the controlling work.

SPT-10.02 TREE REMOVAL:

Tree removal shall comply with the City's tree ordinance. The Contractor will be responsible for securing the necessary permit(s). The Contractor will be responsible for contacting the Parks and Recreation Department for further instruction.

All trees with trunks less than six inches in diameter are not included in this section. Diameter measurement shall be taken below the fork of the tree, 5 ft above ground level. The cost of removing trees less than six inches in diameter shall be included in the various pay items and no separate payment shall be made therefor.

However, when removal of a tree is the only alternative, compensation of such work will be made for the removal of trees greater than six inches in diameter. This bid item includes all costs such as disposal of timber, stumps, roots or any other material resulting from the tree removal. All stumps and roots shall be removed to a depth of at least two feet below finished grade.

The diameter of the trunk shall be determined by measuring the circumference of the trunk at a point 4.5 feet above the existing ground level and dividing by 3.14.

Payment for this item shall be made under SP-10.02.1 Tree Removal 4" to 12", SP-10.02.2 Tree Removal >12" to 18" and SP-10.02.3 Tree Removal >18" to 24".

SPT-10.03 LIVE OAK TREES: - Not Applicable

SPT-10.04 ROOT PRUNING: - Not Applicable

The Contractor shall secure a tree permit from the Parks and Recreation Department when work will be within ten feet of a tree. Tree permit fees are waived.

No excavation shall occur within the radius of protected trees. All roots designated to be removed shall be severed at the perimeter of the designated protected radius leaving a smooth, uniform section at the remaining root end to prevent root damage. Contractor is authorized to prune roots less than two (2) inches in diameter. Root pruning shall be performed with a chain saw, stump grinder, trencher, Dasco root pruner or equal, as approved by the Program Manager. Use of backhoe or axe to shave roots is prohibited. Failure to properly comply with requirements may result in sanctions as specified by Chapter 13 of the City of Tampa Municipal Code.

Root pruning along pipelines, manholes, inlets, and other underground appurtenances and structures shall be considered incidental to sidewalk construction, and no separate payment will be made therefor.

SPT-10.05 TRANSPLANTING TREES: - Not Applicable

SPT-10.06 RESTORATION OF LANDSCAPING WITHIN RIGHT-OF-WAY:

The Contractor shall remove any shrubbery, trees less than 5 inches in diameter, other landscaping, walkways,

planters, other landscaping, and irrigation systems which are in conflict with the proposed construction. These items shall be restored, relocated, and/or reconstructed as shown in the plans or as directed by the Engineer.

Cost of removing, restoring, relocating, and reconstructing the above items shall be included in the lump sum price for Clearing and Grubbing, and no separate payment shall be made.

SPT-10.07 TREE PROTECTION:

Tree barricades shall be constructed and maintained at trees indicated on the plans as "to be protected" and/or as directed by the Engineer. Generally, barricades are to be placed ten (10) feet from the trunk of each protected tree.

Barricades shall be constructed of commercially available pine lumber, as follows: Vertical members shall be 2" x 2" or larger, generally spaced twelve (12) feet apart. Horizontal members shall consist of one (1) 1" x 2" board.

The Contractor shall provide the services of an approved licensed tree professional when it is necessary to trim or cut a branch from a tree.

Payment for tree protection and tree cutting or trimming shall be included in the lump sum price bid for mobilization and/or clearing and grubbing and no separate payment shall be made.

SPT-10.09 TREE TRIMMING:

In addition to Tree Trimming required in the FDOT Standard Specification Section 110, the Contractor shall trim tree limbs and shrubbery to a height of 8 feet above sidewalks and to the right-of-way in the project area, and as directed by the Engineer.

Cost of trimming and disposal of these items shall be included in the lump sum price for Clearing and Grubbing, and no separate payment shall be made.

SPT-11.02 USE OF EXPLOSIVES: - Not Applicable

SPT-11.03 EXISTING PUBLIC FACILITIES:

Existing public facilities that are removed by construction operations under this contract shall be replaced by the Contractor to City of Tampa specifications. These items shall include all public benches, light poles, shelters, roadway signs, etc., and replacement of these items shall be considered incidental to the cost of construction and no separate payment will be made.

SPT-11.04 METAL PRODUCTS: - Not Applicable

SPT-11.05 WATER FOR DUST CONTROL: - Not Applicable

SPT-11.09 CONCRETE BLOCK RETAINING WALLS WITH CONCRETE FOOTING: - Not Applicable

SPT-11.10 MAILBOX RELOCATION:

All mailboxes within the limits of construction shall be removed and reset or relocated to allow access for mail delivery as directed by the Engineer. Cost of this activity shall be included in the cost of the various contract items and no separate payment shall be made.

SPT-11.11 SIGNALIZATION CONDUIT:

Payment for "Conduit Under Pavement" shall be made for any conduit placed in an area outside the limits of clearing and grubbing and which requires pavement removal and restoration, whether the pavement is flexible or rigid.

Payment for backfill, compaction, and pavement restoration shall be included in the unit price for Conduit Under Pavement, and no separate payment shall be made.

Payment for "Conduit Underground" shall be made for any conduit placed in an area which does not require pavement restoration, or which is within the limits of clearing and grubbing. Payment for backfill, compaction, and non-pavement surface restoration shall be included in the unit price for Conduit Directional Bore, and no separate payment shall be made.

Any conduit described as "Additional Conduit" shall refer to conduit placed in the same trench as other conduit whether it is "Under Pavement" or "Underground".

SPT-11.12 RESTORATION OF MONUMENTATION:

The Contractor shall, with no additional payment, re-establish any permanent survey or mapping monumentation which is disturbed or destroyed in the course of the construction project.

SPT-11.13 INSTALLATION OF SIGNALIZATION POLES AND MAST ARMS: - Not Applicable

SPT-11.14 SIGNALIZATION CONTROLLER AND CABINET: - Not Applicable

SPT-11.15 VEHICULAR TRAFFIC SIGNAL ASSEMBLIES: - Not Applicable

SPT-11.16 CONTINGENCY ALLOWANCE:

Payment from the City Contingency Allowance shall be made only at the direction of the Engineer under:

Item No. 0999 25 Contingency Allowance L.S.

SPT-120-1 Special Excavation Root Pruning

Special Excavation Root Pruning shall include excavation of asphalt and road base around trees as identified by the Engineer. For all identified trees for special excavation root pruning: excavation within 20 ft radius of grand trees, excavation within a 10 ft radius of non-grand trees, and all root pruning shall be evaluated and performed by a certified Arborist. Roots shall be covered with temporary base course during construction until final paving. Payment for this item shall be made under SP-120-1 Special Excavation Root Pruning, measured per tree.

TECHNICAL SPECIFICATIONS

1.0 ADMINISTRATION

TS -1.01 TRANSPORTATION AND STORMWATER SERVICES (TSS) TECHNICAL SPECIFICATIONS

Florida Department of Transportation Standard Specifications for Road and Bridge Construction dated 2018 shall be incorporated for construction and materials. Adjust any references to previous editions of the FDOT Standard Specifications and follow current references.

The following hierarchy of the contract documents shall apply:

The TSS Technical Specifications shall govern, except as noted herein.

In the case of apparent conflict with the project plans, the Specific Provisions shall govern.

TS -1.02 SCOPE OF WORK

The work described by these specifications consists of furnishing all labor, equipment, and materials required in performing all operations necessary in connection with street resurfacing, cold milling, concrete work and markings at various locations within the City.

These specifications set forth specific requirements relative to the actual work or services, materials, equipment, and method of construction.

TS -1.03 BID ITEMS

It is the intent of these Contract Documents that any items of work and all costs for which compensation is not directly provided by a bid item but are incidental to various project items of work, shall be prorated and included in the bid item for which they are required.

Quantities are approximate only and actual quantities used during the project may vary greatly from the estimates.

All Superpave Asphaltic Concrete Bid Prices shall be based on "Fine Mixes".

Work will be performed on an as-needed where-needed basis.

TS -1.04 WORK DIRECTIVE CHANGE

A Work Directive Change is a written directive to the Contractor, issued on or after the date of the execution of the Agreement, and signed by the Engineer on behalf of the City, ordering an addition, deletion or revision in the work, or responding to an emergency. A Work Directive Change will not change the contract price or the time for completion, but is evidence that the parties expect that the change directed or documented by a Work Directive Change will be incorporated in a subsequently issued Change Order following negotiations by the parties as to its effect, if any, on the contract price or the time of completion.

Without invalidating the Agreement, certain additions, deletions or revisions in the work may, at any time or from time to time, be authorized by a Change Order or a Work Directive Change. Upon receipt of any such document, the Contractor shall promptly proceed with the work involved.

TS -1.05 NOTICE AND SERVICE THEREOF

All notices, which shall include demands, instruction, requests, approvals, and claims, shall be in writing.

Any notice to or demand upon the Contractor shall be sufficiently given if delivered to the Contractor's representative at the construction site or to the office of the Contractor specified in the bid (or to such other offices as the Contractor may, from time to time, designate to the City in writing), or if deposited in the United States mail in a sealed, postage-prepaid envelope, or delivered, with charges prepaid, to any telegraph company for transmission, in each case addressed to such office.

All notices are required to be delivered to the City shall, unless otherwise specified in writing to the Contractor, be delivered to the Transportation and Stormwater Services Engineer, 306 E. Jackson St, Tampa, Florida 33605, and any notice to or demand upon the City shall be sufficiently in the United States mail in a sealed, postage-prepaid envelope, or delivered with charges prepaid to any telegraph company for transmission, in each case addressed to said Engineer or to such other representative of the City or to such other address as the City may subsequently specify in writing to the Contractor or to its representative at the construction site for such purposes.

Any such notice or demand shall be deemed to have been given or made as of the time of actual delivery or (in the case of mailing) when the same should have been received in due course of post or (in the case of telegram) at the time of actual receipt, as the case may be.

TS -1.06 CONTRACTOR'S REPRESENTATIVE

The Contractor shall submit in writing to the City Pavement Management Engineer the name of its duly authorized representative who will be present on the job during all work activities and is authorized to make decisions for the Contractor. Any change in the contractor's representative shall require written notification to the Construction Engineer prior to such change".

TS -1.07 CONTRACTOR'S FIELD OFFICE

The Contractor will not be required to provide a Contractor's field office.

The Contractor, however, shall have Contract Documents, the latest approved working drawings, standard drawings and a representative of the Contractor available at the site during regular working days.

TS -1.08 ENGINEERING'S FIELD OFFICE

An Engineering field office shall not be required for this project.

TS -1.09 PLACE OF BUSINESS

The Contractor may be required to furnish evidence in writing that he or she maintains a permanent place of business and has adequate equipment, finances, personnel, and inventory to furnish the items offered satisfactorily and expeditiously, and can provide necessary services. An office visit may be scheduled at Engineer's request.

2.0 DESIGN

TS -2.01 DESIGN AND AS-BUILT PLANS

The City reserves the right to request the Contractor to provide the Engineer with Project "As-Built" plans, as follows:

1. All as-built information shall be annotated by a Florida Registered Professional Surveyor and Mapper on a separate layer of an AutoCAD drawing provided by the City, or fully depicted in the form of a new AutoCAD drawing prepared by a Florida Registered Professional Surveyor and Mapper. Annotation or new drawing shall be performed according to City Production and Design Support standards, as well as in accordance with the Minimum Technical Standards set forth by the Florida Board of Professional Surveyors and Mappers in Chapter 61G17-6, Florida Administrative Code, pursuant to Section 472.027, Florida Statutes.

Settings shall be as follows: Color: Red, Linetype: Continuous, Font: Romans, Layer Name: AS-BUILT, AutoCAD Menu Name: ACAD.MNU, File Format: AutoCAD Release 12.

2. All surveys shall be completed by a Florida Registered Professional Surveyor and Mapper in accordance with the Minimum Technical Standards set forth by the Florida Board of Professional Surveyors and Mappers in Chapter 61G17-6, Florida Administrative Code, pursuant to Section 472.027, Florida Statutes.

Survey data shall be submitted by a Florida Registered Professional Surveyor and Mapper, either hired by the Contractor, or in the employment of the Contractor, as electronic data in AutoCAD. ASCII files of digital raw survey data, closure reports, adjustment reports and/or copies of any hand written supporting field notes or sketches will be included in the Drawing submittal

3. "As-built" or "Record" surveys, as may be required by contract, or agreement, will collect and delineate all constructed improvements within the construction site or corridor (or right of way), so that all constructed improvements may be compared to and contrasted with the design plans and/or construction drawings. All improvements shall be deemed to include, but are not limited to, all roads, pavement, pipes, inverts, ponds, ditches, canals, manholes, hand holes, valves, hydrants, poles (utility, telephone, power and otherwise), slabs, inlets, landscaped area, curbs, gutters, traffic controls, utilities, water meters, sidewalks, right of way lines, and other similar items. Specific items may be addressed as part of contract (expressed or waived) or by written agreement from the Engineer.

If Station and Offset delineation is used on the Construction drawings all locations of constructed improvements, as outlined above shall be depicted in similar fashion so that any discrepancy or deviation can be clearly and readily identified.

4. The Contractor shall comply with the above requirements and shall return one check print set of the plans at the same scale as the construction plans and flash drive(s) to the Engineer for review within three weeks of substantial completion of the project as well as applicable ASCII files of digital raw survey data, closure reports, adjustment reports and/or copies of any hand written supporting field notes or sketches. The project will not be considered to be complete and final payment for the project shall not be made until the as-built information is received and approved by the Engineer. Upon approval, the Contractor shall provide the final project construction plans on disk. No separate payment for meeting the above as-built requirements shall be made.

TS -2.02 METRICATION

The Contractor may be required to convert plan units to and/or from metric units in order to comply with Florida Department of Transportation and City of Tampa conversions to the metric system.

No separate payment for conversion of units will be made.

3.0 SCHEDULE

TS 3.01 PRE-CONSTRUCTION CONFERENCE

Prior to the start of the work included in this contract, a Preconstruction Conference will be held by the Engineer to be attended by the Contractor and representatives of the various utilities and others for the purpose of establishing a schedule of operations which will coordinate the work to be done under this contract with all related work to be done by others within the limits of the project. The Contractor shall be prepared for this meeting and shall present a comprehensive construction schedule for all items of work to be accomplished, which will be used as the basis for the development of an overall operational schedule and a list of subcontractors and material suppliers to be used on this work.

At the pre-construction conference, the Contractor will also furnish a proposed payout schedule, and a planned utilization of DBE subcontractors, if applicable. The names and contact information for key onsite project staff, as well as emergency and after-hours contacts, will also be provided by the Contractor. Key contact info for the Engineer will be provided to the Contractor.

TS -3.02 CONTRACTOR'S CONSTRUCTION SCHEDULE

The Transportation and Stormwater Services Department requires the Contractor to provide a project schedule of each project and/or paving area. Paving area is defined by the Engineer as a group of sections designated under a project name. If the Contractor's progress is delayed by a period greater than 1 week in any paving area, the Contractor will re-submit a new schedule.

All items of work in this contract shall be coordinated so that progress on each related work item will be continuous from week to week. The progress of the work will be reviewed by the Engineer at the end of each week, and if the progress on any item of work during that week is found to be unsatisfactory, the Contractor shall be required to adjust the rate of progress on that item or other items as directed by the Engineer. Base shall not be exposed for a period greater than 2 days. If any paving area is behind schedule or otherwise delayed, progress for that paving area shall be reflected in the progress reporting.

The Contractor shall conduct operations in such a manner as will result in the minimum of inconvenience to occupants of adjacent homes and business establishments and shall provide temporary access as directed or as conditions in any particular location may require. Business access will be maintained at all times.

Failure to meet project schedule schedules shall be penalized with the daily rate for liquidated damages, unless extensions are provided in writing that justify the extension of work scheduled.

TS -3.03 WORK DAYS

Except for special operations that may be necessary to maintain, check, and protect work already performed, all work shall normally be discontinued on Saturdays, Sundays and City designated holidays. Should it be desired by the Contractor and accepted by the Engineer to perform weekend and continuous night work, all lighting, safety, maintenance of traffic and other facilities which are necessary for performing such work at night must be provided by the Contractor. Additional payment will be made for Maintenance of Traffic for night work, but must be signed and approved by the Engineer.

TS -3.04 WORK SCHEDULE

Normal working hours are 7:00 AM to 5:00 PM, Monday - Friday. Work on holidays, weekends and evening will only be done if determined by the Engineer. Some streets, arterials and collectors may only be worked on between 9:00 AM and 3:00 PM. The Engineer will inform the Contractor at the Preconstruction Meeting of segments which can only be worked on from 9:00 AM to 3:00 PM.

The beginning date of work to be accomplished under this bid shall be the date set forth in the written Notice to Proceed given to the Contractor. Once started, the work shall be continued without interruption.

The work to be accomplished under this project has been grouped into various areas within the City. The City will assign work to the Contractor an area at a time. The City may request the Contractor to furnish a work schedule at the end of each work week for the following week's work to aid in scheduling City personnel to the best advantage of the Contractor and the City.

The Contractor shall schedule its work so as to maintain at least one-way traffic and shall provide effective dust control at all times. Two-lane traffic shall be maintained wherever possible.

TS -3.05 NIGHT WORK

All night work shall meet the requirements of Section 8-4.1 from the Florida Department of Transportation Standard Specifications for Road and Bridge Construction, 2018 Edition dated July 2018. Lighting plans will be requested upon request of Night work.

4.0 MATERIALS/ EQUIPMENT

TS -4.01 MATERIALS

Construction material and workmanship shall conform to applicable requirements of FDOT Standard Specifications for Road & Bridge Construction, 2018 Edition, Section 334. All materials incorporated in this Contract shall comply with the following FDOT Standard Specifications for Road & Bridge Construction, 2018 Edition. The Contractor shall furnish the Engineer with written certification that these requirements are being met.

TS -4.02 BITUMINOUS MATERIAL

Add to the mix the type and quantity of bituminous material as determined by Design. Use bituminous material conforming to the applicable requirements of FDOT Standard Specifications for Road and Bridge Construction 2018. The following material should be used: Emulsified Asphalt, CSS-1H, E-18R or approved equivalent alternate.

TS -4.03 AGGREGATE

FDOT Standard Specifications for Road and Bridge Construction 2018, Section 901-1.4, Nos. 57 and 67, No. 2. Add the gradation and quantity to the mix as required by field conditions or as directed by the Engineer.

TS -4.04 TESTING

Permission to test streets must first be obtained from the Engineer. Core samples holes must be patched with cold patch. Supply representative samples of the RAP material or pavement core samples, bituminous materials, and virgin aggregate to a laboratory for preliminary testing to determine the optimum moisture content, type of bituminous material, and proportions. Obtain guidelines on sampling procedures from the Florida Method of Sampling and Testing as found in the Field Sampling and Testing Manual. The City's Standard Operating Procedure for Construction Inspection for Resurfacing Projects should be followed relative to sampling and testing.

Testing will be accomplished in compliance with the City's Standard Operating Procedure for Construction Inspection for Resurfacing Projects.

TS -4.05 MIXTURE

Combine the reclaimed material, aggregates, and bitumen, meeting the requirements specified, in such proportions that the total aggregate and bitumen in the base course conforms to a mixture of acceptable composition and stability. Make field adjustments to the recommended mix design under the guidance of a knowledgeable and competent technician to obtain a satisfactory recycled mixture.

In addition, the Contractor shall submit to the Engineer, in writing, the proposed asphalt mix designs and test data with sufficient samples for study, evaluation, and testing. A minimum of ten days shall be allowed for the Engineer to approve or recommend changes.

The City's Standard Operating Procedure for Construction Inspection for Resurfacing Projects should be followed relative to sampling, testing, and placement of mix.

TS -4.06 DELIVERY TICKETS

All delivery tickets and notes regarding any materials brought to the project site to complete this Contract must be given to the Engineer upon delivery to the project site. These tickets must be signed by the Engineer at the time of delivery.

TS -4.07 METER READINGS

Before the start and at the end of each day's work, the Engineer must be permitted access to the mixing equipment in order to read the meter to verify the quantity of asphalt emulsion applied during the day's work.

TS -4.08 FURNISH & INSTALL FDOT TYPE SP-12.5 OR SP-9.5 ASPHALT

The Contractor shall furnish all the equipment, materials and install the overlay of SP-12.5 or SP-9.5 Asphaltic Concrete in full and complete accordance with the latest edition of FDOT's Standard Specifications for Road and Bridge Construction. Payment will be full compensation for the asphalt overlay and made under the Proposal Item unit price for Furnish & Install FDOT Type SP-12.5 or SP-9.5 Asphalt, by the ton.

TS -4.09 BITUMINOUS MATERIALS ESCALATION

Due to rapidly fluctuating oil prices, Emulsion and Asphaltic Concrete price adjustments may occur. A current FDOT Fuel and Bituminous Price Index must be submitted with the bid stating what the initial bid prices were based upon. These price indexes are located at the following FDOT website address: <http://www.dot.state.fl.us/construction/fuel&bit/Fuel&Bit.shtm>.

Adjustments for Asphalt Cement (AC-20/30), Polymer Materials, Cutback (RC-70) and Emulsified Asphalts (RS-1/RS-2) will be calculated from the latest FDOT Fuel and Bituminous forms and specifications, currently #700-050-66, dated February 2007. This form is located at the following FDOT website address: <http://www.dot.state.fl.us/construction/fuel&bit/FuelForms.shtm>. Adjustments shall be discussed at the preconstruction meeting and finalized prior to starting work for each project. The City, at its sole discretion, shall determine if the price adjustment is acceptable and provide written acceptance of the price revisions prior to start of any work on the project. The City will not compensate the Contractor for any work that is done without prior written consent of any pricing adjustments.

TS -4.10 METHOD OF MEASUREMENT

When placing asphalt, the Contractor shall be paid based on the tons of asphalt placed (lbs per sq yd) as directed by the Engineer.

First, the Engineer shall predetermine the amount of asphalt to be placed for each individual job. The Engineer shall specify the amount on a job-by-job basis prior to the particular job commencing. The Contractor shall then be allowed to vary the actual amount of asphalt placed by +/- 5 lb. per sq. yd. of the amount specified.

If the Contractor places within +/- 5 lbs. per sq. yd. of the amount of asphalt specified by the City, then the City shall pay said Contractor for the exact amount of asphalt placed.

If the actual amount of asphalt placed by the Contractor is less than the +/- 5 lbs. per sq. yd. range specified above, then the Engineer will be given the following two options:

- (1) The work shall be deemed unacceptable and the Contractor shall be required to rework the entire work area so as to comply with the work order. There shall be no additional compensation for this work;
- (2) The Engineer may elect to pay the Contractor for the amount of asphalt actually placed.
If the actual amount of asphalt placed by the Contractor is greater than the amount of asphalt +/- 5 lbs. per sq. yd., then the City shall pay for only the specified amount plus 5 lbs. per sq. yd.

TS -4.11 DENSITY CONTROL AND PAYMENT SCHEDULE

Construction Materials testing services shall be provided by the Contractor. The Contractor shall use a City approved independent lab to perform all testing services. The cost of density tests shall be included in the cost of the related work.

TS -4.12 EQUIPMENT

The equipment for this operation shall be a machine capable of maintaining a depth of cut and cross slope, which will achieve the results, specified herein.

The machine shall be equipped with automatic grade controls which operate by sensing from one or more skids moving along the pavement surface and where required shall produce a skid resistant surface texture. The machine shall be equipped with a means to effectively limit the amount of dust escaping from the removal operations

Milling equipment shall meet the specifications of FDOT Standard Specifications for Road & Bridges, 2018 Edition, Section 327. Equipment shall have a built-in automatic grade control, cross slopes control, and have a minimum cutting width of 6 feet.

Paving equipment shall meet the specifications of FDOT Standard Specifications for Road & Bridges, 2018 Edition, Section 330. Equipment shall come with automatic screed control, with screed width varying from 5 feet to full width lanes. Target spread rate shall adhere to Table 330-2 in FDOT Standard Specifications for Road & Bridges, 2018.

Steel wheeled and traffic rollers will be necessary to attain compaction.

TS -4.13 METAL PRODUCTS

All metal products incorporated into the project must be tested by and found to conform to applicable specifications by an approved private testing laboratory prior to use on the project. These acceptance reports must also be made available to the Construction Engineer and to be placed in its office file prior to use on the project.

TS -4.14 STABILIZATION:

Type "B" stabilization shall obtain a minimum Limerock Bearing Ratio (LBR) of 40. Type "C" stabilization shall obtain a minimum Florida Bearing Value (FBV) of 75 p.s.i.

TS -4.15 WARM MIX ASPHALT

Evaluated in accordance with AASHTO T195 needs to contain a minimum of 95% coating. The WMA shall obtain a compactability ratio of less than or equal to 1.25. The rutting resistance of the WMA shall be evaluated in accordance with AASHTO T79. The WMA shall achieve minimum flow numbers in accordance with the following table:

WMA Flow Number	
Traffic Level, Million ESALs	Minimum Flow Number
<3	N/A
3 to <10	30
10 to <30	105
>30	415

Warm mix technologies will be limited to chemical additives only and shall be capable of reducing mixture compaction temperatures by a minimum of 50^oF. Additives possessing anti-stripping properties are preferred. Approved chemical additives are listed on the Department's website. The URL for obtaining this information, if available, is:

<http://www.dot.state.fl.us/statematerialsoffice/quality/programs/warmmixasphalt/>

5.0 PRE-CONSTRUCTION OPERATION

TS -5.01 CITY PERMITS

The Contractor shall be responsible for obtaining all applicable City permits for this project. These can include, but may not be limited to, Right-of-Way Permit(s) and Maintenance of Traffic approval. The Contractor shall supply any required plans or other information to the issuing department.

The time required to prepare, submit, review, and issue the permits shall be included in the Award time and no payment shall be made for any delay incurred by this process.

Cost for obtaining City permits shall be included in the unit costs for the various items and no separate payment shall be made. The Right-of-Way permit fee shall be waived by the City.

All subcontractors working on the project shall obtain their own, separate, permits as above.

TS -5.02 PERMITS

It shall be the Contractor's responsibility to familiarize themselves and comply with all such local regulations as well as State and Federal rules and to obtain all necessary permits.

TS -5.03 ENVIRONMENTAL PROTECTION

The Contractor will be held liable for the violation of any and all environmental regulations. Violation citations carry civil penalties and in the event of willful violation, criminal penalties. The fact that the permits are issued to the City does not relieve the Contractor in any way of its environmental obligations and responsibilities. Contractor shall not use any materials that have become contaminated or otherwise unfit for use.

TS -5.04 RESIDENTS NOTIFICATION

The Contractor shall distribute, by hand, a typed notice to all residences and businesses on the street to be resurfaced. The notice will be delivered 7 days and again at 24 hours prior to resurfacing of the road. The notice will have a local phone number that residents may call to ask questions. The notice shall be of the door hanger type which secures to the door handle of each dwelling. Unsecured notices will not be allowed. The Contractor shall also place the notice on the windshield of any parked cars on the street. Hand distribution of this notice shall be considered incidental to the award, and no additional compensation will be allowed.

TS -5.05 PROJECT PHOTOGRAPHS

The Contractor will not be required to furnish photographs of the project, but is in their best interest to document project area. The Engineer may or may not take photographs of the area prior to and after completion of the construction for record and information. To assure that there will not be any conflict with this photography, the Contractor shall not perform cleaning operations or action which will disturb any street or area within the project until the Engineer has been advised thereof and has had adequate opportunity to perform the desired photography.

TS -5.06 PROJECT VIDEOGRAPHY

Prior to commencing work on a project, the Contractor shall submit to the Engineer for approval, a DVD containing a continuous color video recording including complete coverage of pre-construction conditions of all surface features within the construction's zone of influence, (including detour routes) simultaneously produced audio commentary and electronic display of time and date. The video recording shall be sufficient to fulfill the technical and forensic requirements of the project and provide continuous unedited coverage, establishing locations and viewer orientation with clear, bright, steady, and sharp video images with accurate colors free of distortion or other imperfections. The DVD must be accompanied by a detailed log of its contents including date, locations, video counter numbers and features. No work shall be allowed until the completed DVD and log are approved by the Engineer.

Construction Engineer will make decision that project videography is needed or not for the assigned project.

TS -5.07 STREET CLOSURES AND MAINTENANCE OF TRAFFIC

A City of Tampa permit for construction and maintenance operations within public Rights-of-Way will be required for every street, lane, or sidewalk closure within City of Tampa Rights-of-Way.

A State of Florida Department of Transportation Permit will be required for every street, lane, or sidewalk closure within State of Florida Rights-of-Way. The Contractor, as the organization performing the work, will secure this permit.

These permits will establish the requirements for the closure related to number of lanes and/or time of day lanes or street may be closed. The Contractor shall adhere to the requirements as described in the permit(s).

The Contractor shall furnish and maintain all necessary signs, arrow boards, pavement markings, barricades, traffic cones, lights, law enforcement officers and flagmen necessary to control traffic and provide for safety of the public, all in compliance with the current Florida Department of Transportation Roadway and Traffic Design Standards and the FHWA Manual on Uniform Traffic Control Devices. The Contractor shall observe traffic movements through the work site and inspect all traffic control devices on a regular basis to ensure that all devices are properly installed and functioning as intended.

The City shall have the discretion of using its own supply of traffic control devices or to utilize items provided by the Contractor, whichever is deemed in the City's best interest. In the event that Contractor supplied message boards are to be utilized during a project, the Contractor shall provide pricing information related to supplying the items to the Engineer at each project's Preconstruction meeting. The City will provide written acceptance of the pricing information prior to the start of work on the project and the Contractor will be compensated upon received invoice. A separate line item for each charge should be reflected on the invoice and charged to the Contingency line item. In addition, the Contractor will be responsible for the payment of any law enforcement officers at cost upon receipt of invoice from the appropriate agency and will be required to provide this information to the City for payment. Payments will be authorized from contingency; no payment will be made to the Contractor related to any of these items without the City's prior written approval.

Advance notice information signs/Message boards advising the public of scheduled closure of major roadways and/or information signs advising the public of points of closure and detour routes may be required by the Engineer. The number of message boards, location(s) and time duration required will be determined by the Engineer prior to each project. The City shall have the discretion of using its own supply of message boards or to utilize message boards provided by the Contractor, whichever is deemed in the City's best interest.

In cases of closure for street, lane, or sidewalk on the City of Tampa Functionally Classified Network (collectors, minor arterials, and principal arterials) including all State Roads, the Contractor shall provide a Right of Way Permit from the Authority having Jurisdiction with an accompanying maintenance of traffic plan to the City of Tampa, Transportation Division. All cost for any unplanned street closure shall be addressed through the construction contingency after receiving the Engineers approval. This plan shall be provided at least 72 hours in advance of the closure (excluding weekends) and shall contain the following:

Proposed detour routes.

Signing of the complete construction area and detour routes.

Payment shall be full compensation for all work, equipment, materials, tools, labor and any incidentals required to maintain safe traffic routes past the work site.

Maintenance of traffic shall be considered part of the general cost of doing work and should be included in the bid prices.

The Contractor shall preserve from damage all property within the work area consistent with Section 7-11 of the FDOT Standard Specifications for Road and Bridge Construction, 2018 Edition.

TS -5.08 CONSTRUCTABILITY

Construction materials and workmanship shall conform to applicable requirements of FDOT Standard Specifications for Road & Bridge Construction, 2018 Edition. The Contractor shall furnish the Engineer with written certification that the following requirements are being met:

- (1) A leveling course may be required to correct the profile of the road and after cold milling. The type of mix and the depth of the leveling will be decided in advance by the Engineer;
- (2) Surface Course Type SP-12.5 and Type SP-9.5 shall conform to FDOT Standard Specifications for Road & Bridge Construction, 2018 Edition, and latest supplemental specifications;
- (3) Asphaltic Concrete Pavement. All asphalt pavements shall be constructed of asphaltic concrete of type and thickness as shown in the specifications and placed where directed by the Engineer. Construction material and workmanship shall conform to applicable requirement of FDOT Standard Specifications for Road & Bridge Construction, 2018 Edition, and latest supplemental specifications.

In addition, the Contractor shall submit to the Engineer, in writing, the proposed asphalt mixes and sufficient samples for study and testing. A minimum of ten days shall be allowed for the Engineer to approve or recommend changes.

TS -5.09 ADJUSTMENT OF UTILITIES AND PUBLIC SERVICE INSTALLATIONS

Storm and sanitary sewer manhole covers, valve covers or boxes, water meter boxes, and vaults located within the limits of construction of the pavement or sidewalk area to be constructed, reconstructed or overlaid shall be relocated or adjusted by the Contractor to conform with the new pavement or sidewalk elevation as a part of the work of constructing or reconstructing the pavement or sidewalk and no separate payment will be provided therefore.

Appurtenances of other utilities will be relocated or adjusted by the utility company owning or having jurisdiction over the respective utility.

Any potential impacts or adjustments to utilities that may be required shall be identified by the Contractor and provided in writing to the Engineer.

TS -5.10 REMOVAL OR ADJUSTMENT OF PUBLIC UTILITIES

The City will make necessary arrangements with public utility owners, other than City of Tampa Water and Sanitary Sewers, for removal or adjustments of existing utilities, whether shown or not shown on the plans, where such removal or adjustment is determined by the Engineer to be essential to the performance of the required construction, provided normal construction procedures are used by the Contractor.

Relocations or adjustments requested by the Contractor on the basis of the use of a particular method of construction or a particular type of equipment shall not be considered as being essential to the construction of the project if other commonly used methods or equipment could be employed without the necessity of relocating or adjusting the utility. The Engineer will determine the responsibility for any such adjustment of utilities.

Relocations or adjustments requested for the Contractor's convenience or because of delivery of materials to the job site shall be the responsibility of and at the expense of the Contractor. The Contractor shall be required to coordinate its activities with relocation work by the utilities. A schedule for relocation work will be presented to the Contractor at the pre-construction conference. This schedule may be adjusted to "fit" the Contractor's proposed schedule, but it will include periods during which the Contractor's ability to perform work in the relocation area will be limited, with no additional compensation.

TS -5.11 USE OF CITY WATER SYSTEM

A Tampa Water Department portable meter shall be utilized when obtaining water from the City system. Contractor shall include all coordination, application fees, deposits and services fees in the bid.

TS -5.12 LINES AND GRADES

All work done under this contract shall be constructed in accordance with the proposed lines and grades as shown on the plans or as directed by the Engineer. The full responsibility for keeping alignment and grade shall rest upon the Contractor.

Contractor shall regrade and reprofile all pavement that is within the limits of milling and resurfacing to ensure positive drainage and prevent standing water. Regrading and reprofile shall be included in cost of milling.

If the roadway profile is not built according to design specifications, the Contractor assumes full responsibility to repair the location according to plans. Acceptable forms of repair require saw cutting or milling a minimum of a full lane width to adjust grade. No patch overlays will be accepted as a fix.

The Engineer will establish Bench Marks and baseline controlling points only. All reference stakes cost will be part of the Contractor's unit price for asphalt.

These stakes shall be maintained for the duration of construction for the purpose of the Engineer's reference.

Project pay items requiring survey information, such as embankment or excavation, shall be documented by a Florida Registered Professional Surveyor and Mapper. In addition, plotted cross sections and quantity

computations must be supplied and certified. All surveys shall be in accordance with the Minimum Technical Standards set forth by the Florida Board of Professional Surveyors and Mappers in Chapter 61G17-6, Florida Administrative Code, pursuant to Section 472.027, Florida Statutes.

TS -5.13 FILLING LOW AREAS WITHIN CITY LIMITS

The Contractor under Sec. 21-27 (Permit Requirements) of the City of Tampa Code is prohibited from filling any area public or private (except where shown on the construction plans) within the project limits or anywhere within the City limits without a permit.

For filling and/or grading any area, the owner of such area shall obtain a permit from the Stormwater Management Division, Department of Sanitary Sewers, City of Tampa. The owner shall submit existing and proposed contour plans of the area to be filled and the adjacent land for determination if a permit could be issued. Drainage patterns cannot be altered to the detriment of neighboring property owners or public rights-of-way.

Concurrently the permit application will be reviewed by the Parks Department.

The Contractor shall not deposit any fill material within the City limits without an approved permit. A copy of the permit shall be submitted to the Engineer, by the Contractor prior to any filling or grading operation.

TS -5.14 PRE-CONSTRUCTION TESTING

The Contractor is required to take representative core samples of the roads proposed in this Contract to insure adequate depth of suitable material. Representative core samples is defined as per street basis, not exceeding three (3) blocks. The results of these core samples, along with a suggested mix design of asphalt content must be submitted to the Engineer. No additional payments will be made for coring.

TS -5.15 TREE REMOVAL

The work included in this Section consists of removal of all trees within the area of construction with trunks 5 inches or more in diameter. Tree removal shall comply with the City of Tampa Tree Ordinance. The Contractor will be responsible for obtaining the necessary permit(s) and paying the necessary fees.

All trees with trunks less than 5 inches in diameter are not included in this section. The cost of removing trees less than 5 inches in diameter shall be included within the various contract items and no additional payment shall be made.

The diameter of the trunk shall be determined by measuring the circumference of the trunk at a point 4.5 feet above the existing ground level and dividing by 3.14.

All trees indicated for root pruning shall have stumps and roots removed to a depth of at least 2 feet below the finished grade.

Disposal of timber, stumps, roots or any other material resulting from the tree removal operation shall be the sole responsibility of the Contractor. Such disposal shall have the approval of the Engineer.

Payment shall be full compensation for all work, equipment, tools, labor, disposal and any incidentals required for completion of the work.

TS -5.16 ROOT PRUNING

The Contractor shall make provisions for tree protection to the satisfaction of the Engineer prior to any excavation or clearing and grubbing. All applicable site inspections by the City of Tampa Parks Department and all permits required for tree work shall be obtained by the Contractor prior to commencing work.

The Contractor shall furnish all labor, materials, equipment and services necessary to prune the tree roots as shown on the plans, as specified, and as directed by the Engineer. The Contractor shall provide root pruning services only as shown on the plans and as directed by the Engineer.

All root pruning shall be performed by a qualified, licensed tree professional as approved by the Engineer. Root pruning shall be performed with a chain saw, stump grinder, trencher, Dasco root pruner or equal, as approved by the Engineer.

Root pruning along pipelines, manholes, inlets, and other underground appurtenances and structures will be included for payment under this contract item. The quantity of root pruning, in linear feet, to be measured for payment will be the actual length of root pruning performed within the limits shown on the plans, in the specifications, or as directed by the Engineer. Depth of root pruning shall be as directed by the Engineer.

All roots designated to be removed shall be severed at the perimeter of the designated protected radius leaving a smooth, uniform section at the remaining root end to prevent root damage. No excavation shall occur within the radius of the protected area.

The work includes all cutting, excavation, removal, hauling, and disposal of roots; filling, grading, mulching, barricading and other appurtenant work complete, in place.

TS -5.17 TREE PROTECTION

Tree barricades shall be constructed and maintained at trees indicated on the plans as "to be protected" and/or as directed by the Engineer. Generally, barricades are to be placed ten (10) feet from the trunk of each protected tree.

Barricades shall be constructed of commercially available pine lumber, as follows: Vertical members shall be 2" x 2" or larger, generally spaced twelve (12) feet apart. Horizontal members shall consist of one (1) 1" x 2" board.

The Contractor shall provide the services of an approved licensed tree professional when it is necessary to trim or cut a branch from a tree. Work shall be performed in accordance with ANSI A300.

TS -5.18 TREE TRIMMING

The Contractor shall be responsible for trimming any limbs or shrubbery that may interfere with its equipment and as directed by the Engineer. Cost of trimming and disposing of these items shall be included in the bid items for asphalt and no other payment shall be made. Work shall be performed in accordance with ANSI A300.

TS -5.19 PARKING METERS

The Contractor shall reimburse the Logistics and Asset Management Department, Parking Division located at 107 N. Franklin Street, Tampa, Florida 33602 for any and all metered parking spaces occupied or made unusable or unavailable as a result of or because of construction activity by the Contractor. Private automobiles may not be parked in any reserved space.

In order to receive temporary or permanent reserved signs in parking areas which are regulated by parking meters, payment shall first be paid to the Parking Revenue Fund for the elimination of each such meter a charge based on the following schedules:

- (1) In one dollar and twenty-five cents (\$1.25) per hour metered areas, a charge based on twelve dollars and fifty cents (\$12.50) per day with a minimum of twelve dollars and fifty cents.
- (2) In fifty cents (\$0.50) per hour metered areas, a charge based on five dollars (\$5.00) per day with a minimum of twelve dollars and fifty cents.
- (3) In thirty cents (\$0.30) per hour metered areas, a charged based on three dollars (\$3.00) per day with a minimum of twelve dollars and fifty cents.
- (4) In twenty-five cents (\$0.25) per two hours metered areas, a charged based on one dollar and twenty-five cents (\$1.25) per day with a minimum of twelve dollars and fifty cents.

- (5) During non-operational hours (i.e., Sundays, Holiday, and weekdays after 6:00 p.m.) in metered areas, a charge based on two dollars (\$2.00) per day with a minimum of twelve dollars and fifty cents.

In the event that an entire block or area of parking meters are reserved for a period of 90 days or longer, the Contractor may arrange a payment schedule with the Logistics and Asset Management Department, Parking Division. Said payment schedule will be paid on a monthly basis after a deposit equivalent to the first and last month rental charges has been received by the Parking Division prior to commencement of construction.

Any meter or meters which may sustain damage due to construction activities in the immediate area must be removed. The meter removal/installation charge is \$7.50 per meter. Failure to have a meter(s) removed will result in the Contractor being held liable for damage occurring to said meter(s) and further, the Contractor will be required to reimburse the Logistics and Asset Management Department, Parking Division for meter(s) repaired or replaced.

TS -5.20 MAILBOX RELOCATION

All mailboxes within the limits of construction shall be removed and reset or relocated to allow access for mail delivery as directed by the Engineer. Cost of this activity shall be included in the cost of the various contract items and no separate payment shall be made.

TS -5.21 UTILITY PROTECTION CONSIDERATIONS

The Contractor shall protect all utilities and other facilities within and adjacent to the construction as covered in Section G-1.03, unless a utility firm has conclusively indicated, or such is shown on the plans, that the certain adjustment, removal, reconstruction, or protection of the utility's facility will be performed by that respective utility.

The Contractor shall make every effort to protect all water mains. If the main is damaged or lost, the Contractor shall replace the affected line in strict accordance with the City of Tampa Water Department Specifications and Construction Standards, latest edition, at no extra cost to the City, and he shall assure that service is maintained at all times.

The Contractor shall make every effort to protect all sanitary sewer lines. If the main is damaged or lost, the Contractor shall replace the affected line in strict accordance with the City of Tampa Wastewater Department Specifications and Construction Standards, latest edition, at no extra cost to the City.

It will be the Contractor's responsibility to preserve all existing sanitary sewer services without interruption during the construction of storm sewers or the repairs or reconstruction of sanitary sewers.

When the construction of storm sewers, repair or reconstruction of sanitary sewers has been completed, all temporary connections shall be removed. Sewers shall be cleaned of all settled solids.

The cost of handling sanitary sewers during construction, including cost of all labor, materials, and equipment or other items incidental to completing the job, shall be included in the contract price as bid for the contract items and no separate payment shall be made.

It will be the Contractors responsibility to preserve all existing ditches, swales, force main, gravity main, laterals, gas, etc., and other stormwater appurtenances and facilities pertaining thereto whether owned or controlled by City, other governmental bodies or privately owned by individuals, firms or corporations.

Any temporary measures constructed shall first be approved by the Engineer. The cost of such temporary measures shall be included in the contract price bid for storm sewer items and no separate payment shall be made.

The Contractor shall furnish, install, and remove sheeting and shoring and other protective measures as may be necessary to satisfactorily accomplish the construction of this project. The cost of such sheeting and shoring and other protective measures shall be included in the unit prices as bid for the storm sewer items and no separate payment shall be made.

In the event that a utility line or structure is damaged, the Contractor must inform the Engineer and perform the necessary repairs. If any utility damage is left unrepaired, all materials and work completed above the utility will need to be removed and replaced with new material. All cost for this repair will be the sole responsibility of the Contractor.

TS -5.22 CSX Coordination Requirements

Special insurance may be requested upon working on CSX related projects. The Contractor agrees to attain the minimum insurance requirements at no cost to the City to complete CSX related projects.

6.0 MILL AND OVERLAY OPERATION

TS -6.01 MOBILIZATION

All work shall meet the requirements of Section 101 of the FDOT Standard Specifications for Road and Bridge Construction.

The cost of mobilization for each project will be paid as 10% of the construction cost. The 'construction cost' is the cost of the project pay items actually used to complete the project, except the cost for M.O.T.

In case, if the project/ WO cost less than \$25,000.00, the Contractor will get paid \$2,500.00 for the Mobilization.

TS -6.02 COLD MILLING

The work specified in this section consists of removing existing asphaltic concrete pavement to improve the ride characteristic or to lower the finished surface adjacent to existing curb prior to resurfacing, thereby re-establishing proper drainage.

Transporting and stockpiling the milled asphalt pavement to a storage area designated by the Engineer will be the responsibility of the Contractor. The salvaged material from this project shall remain the property of the City of Tampa.

The Contractor shall provide competent, suitable, qualified personnel to lay-out the work and perform the construction as required by the Contract Documents. Good discipline and order at the job site shall be maintained at all times. The Contractor shall furnish all materials, equipment, labor, transportation, fuel, power, telephone, water and sanitary facilities and incidentals necessary for the execution, testing, operation and completion of the work.

The existing pavement shall be milled to varying depths in a manner which will restore the pavement surface to a uniform longitudinal profile and cross slope of 0.02 feet per foot. However, should variations be necessary, the cross slope shall be between 0.015 feet per foot to 0.04 feet per foot, unless a design plan states otherwise. Hence, pavement will be restored to design specifications or typical sections provided. The longitudinal profile of the milled surface shall be established by skid sensor on the side of the cut nearest the centerline of the road. The cross slope of the milled surface shall be established by a second skid sensing device near the outside edge of the cut or by an automatic cross slope control mechanism. The City may waive the requirements for the automatic grade or cross slope controls where the situation warrants such action. The Engineer prior to starting each phase will approve the milling pattern, in conjunction with the lay-down operation.

The Contractor may elect to make multiple cuts to achieve the required pavement configuration or depth of cut if approved by the Engineer. All material shall be removed around manholes, valve boxes, etc. and to the curb.

At streets that intersect streets being resurfaced, resurfacing shall extend onto the intersecting street to the pedestrian crossing turns and over the areas along the radii of all returns, so as to maintain the drainage pattern of the intersection. The Engineer should be notified in the occasion where the grade change would cause vehicles to scrape roadway surface. At the pedestrian crossing, the resurfacing shall be feathered into the existing pavement of the intersecting street.

The milling machine shall be operated to effectively minimize the amount of dust being emitted from the machine. Pre-wetting of the pavement may be required.

In areas where traffic will be maintained over milled surfaces, adequate transition to non-milled surfaces will be provided to maintain a smooth longitudinal driving surface. Temporary driveway ramps may be necessary during construction to prevent cars from bottoming out when surfaces are milled.

TS -6.03 REMOVAL OF BRICK PAVEMENT

Work shall consist of all labor, equipment, materials, and incidentals required for complete removal of brick pavement where shown in the plans or ordered by the Engineer to be removed or where required to be removed because of the construction operations. Contractor shall palletize and wrap brick in plastic sheeting. Pallets of plastic wrapped bricks shall be delivered to the City of Tampa's designated facility. Contractor is responsible for loss, theft, vandalism, or careless handling from the time of removal until Final Acceptance of the work.

TS -6.04 REMOVAL AND/OR INSTALLATION OF BRICK PAVEMENT

Work shall consist of all labor, equipment, materials, and incidentals required for removal and/or installation of brick pavement, including base and leveling sand, as shown in the plans or directed by the Engineer. For installation only work, the bricks shall be supplied by the City of Tampa. Contractor shall be responsible for loss, theft, vandalism, or careless handling of all on-site bricks until Final Acceptance of the work.

Subgrade:

This work consists of bringing the area to be repaved to a subgrade conforming to the required grade and cross section surface of uniform density ready to receive the base course. This is to be accomplished by excavating or backfilling as needed, shaping, and then rolling the entire area with an approved self-propelled tandem roller weighing not less than 8 tons. Shaping and rolling to continue until subgrade has been properly prepared and shows that no further compaction of any practical benefit would result from continued rolling. It shall be tested as to cross section, crown, and elevation. After being properly prepared, it shall be so maintained until the base course is constructed. A completed subgrade shall be maintained sufficiently in advance of the base course operations to permit of proper control. Any part of the subgrade area inaccessible to the roller shall be thoroughly compacted by hand or power tamping in a manner acceptable to the engineer. Subgrade shall be minimum 12" and be compacted to 98% per AASHTO T-180.

Base:

This work consists of placing 10" of crushed concrete base material atop the prepared and accepted subgrade. The base will be placed in at least two lifts. The 10" crushed concrete will have a minimum LBR of 100 and will be compacted to 98% per AASHTO T-180.

Where a base is encountered under brick pavement, it shall be restored to the same thickness with the approved crushed concrete material before relaying the brick pavement.

Sand Cushion:

A sand cushion shall be constructed on all completed bases for vitrified brick pavement. The sand cushion shall be sharp sand composed of clean sand, free from clay, loam and other foreign matter, and shall be constructed to a uniform thickness of 1-inch upon the completed crushed concrete base. The sand cushion shall be shaped to a true surface parallel to the required surface of the pavement when finished. The sand cushion shall be prepared at least 25-feet in advance of laying the brick, where possible. Care shall be exercised that the sand cushion is not disturbed or compacted until the brick are in place and ready for rolling.

Vitrified Brick Pavement:

Vitrified brick pavement shall be re-laid at locations called for by replacement schedule for street paving disturbed by construction operations, as shown on the plans. Vitrified brick pavement shall be re-laid on a completed base with a sand cushion and only clean whole, sound brick shall be used. Acceptable brick removed from the disturbed areas removed by the contractor and/or removed from the City of Tampa stock pile, will be used for this repaving and shall not be hauled or moved by the contractor for use elsewhere unless directed by the engineer.

The brick shall be laid in straight courses, flat on the prepared sand cushion, with the better side of face upward. The brick shall be laid in close contact and the joints of each course shall be uniformly staggered with respect to adjacent courses. Whole brick shall be used except in starting or finishing a course and in fitting brick pavement around manhole tops or other structures. In general, not less than one-fourth of brick shall be used in batting.

A timber straight edge shall be driven against every fourth course of brick by light blows with sledge or maul to straighten the lines and eliminate appreciable space between bricks.

The surfaces shall be swept clean and rolled with a tandem static roller weighing not less than 5 nor more than 8 tons in a manner to firmly and uniformly embed each brick in the sand cushion so that the completed pavement shall conform to the required crown, grade, and cross section.

The joints of the vitrified brick pavement replacement shall then be filled with a 1:4 sand/cement mixture and/or pure sand. If pure sand, the pure sand must be sealed with Surebond SB-1300 Sealer or approved equal. The 1:4 sand/cement mixture of mortar grout shall be "soupy" and swept in with street brooms or may be dry mixed, swept in with street brooms, consolidated by vibratory methods, and sufficiently moistened to ensure that cement sets. If "soupy" application is used, then Contractor will blot the joints with sand after sweeping application to remove excess grout.

The application of joint filler should take place immediately after laying the brick or as soon as possible thereafter to prevent joint from filling with other foreign matter.

TS -6.05 SWEEPING

Prior to opening to traffic to an area which has been milled, the pavement shall be thoroughly swept by Contractor with a power broom or other approved equipment to remove, to the greatest extent practicable, fine material that could become dust under traffic. This operation shall be conducted in a manner so as to minimize the potential for creation of a traffic hazard and to minimize air pollution.

Sweeping of the milled surface with a mechanical-type sweeper will be performed just prior to placing the new asphalt concrete. All sweeping by the Contractor will be performed by equipment that has a working water spray system to minimize dust.

TS -6.06 STREET ACCESS

Access to adjacent residential, public and commercial properties shall be provided at all times during the contract period.

TS -6.07 PRIME/TACK COAT

Prime/ Tack Coat shall be per FDOT Standard Specifications for Road & Bridges, 2018 Edition, Section 300, unless noted otherwise.

TS -6.08 PROJECT CLEAN-UP

Clean-up is extremely important and the Contractor will be responsible for keeping the construction site neat and clean with debris being removed regularly as the work progresses.

The work specified in this section consists of the application of water within the limits of construction of the project or on streets used as detour routes in connection with the project, in accordance with these specifications. All dust control operations shall be performed by the Contractor at the time, location, and in the amount ordered by the Engineer. The application of water shall be under the control of the Engineer at all times. No payment will be made for any work performed or water used to control dust where it is applied without authorization of the Engineer. Water ordered by the Engineer to be applied on Saturdays, Sundays, or legal holidays will be paid for at the contract unit price as bid for the time of dust control work involved and no additional compensation will be allowed therefore.

Water used for dust control shall be free from pollution to the extent that its use will not constitute a nuisance or health hazard to anyone living in close proximity to the areas where it is used.

The quantity of water measured by an approved device or other means of determining the measurement of water as approved by the Engineer will be paid for at the contract unit price per thousand gallons for this item, which price and payment shall be full compensation for the cost of all materials, equipment and the work for watering.

TS -6.09 FINISHED SURFACE

The milled surface shall have a texture which will produce acceptable bonding.

The finished surface shall have a reasonable uniform texture and shall be within 1/4 inch of a true profile grade and shall have no deviation in excess of 1/4 inch from a straight edge applied to the pavement perpendicular to the center line. Areas varying from a true surface in excess of the above stated tolerance may be accepted without correction if the Engineer determines that they were caused by a pre-existing condition which could not have reasonably been corrected by the milling operations. Any unsuitable texture or profile, as determined by the Engineer, shall be corrected by the Contractor at no additional compensation.

The Engineer may require re-milling of any area where a surface lamination caused a non-uniform texture to occur.

TS -6.10 MANHOLES

Any manhole covers protruding more than 1" above the milled surface shall have asphalt applied and tapered to existing surface all around the manhole to allow smooth transition for the motoring public. The City should try to coordinate with the respective department to have manholes lowered

For milling operations, all material shall be removed around manholes

Where it becomes necessary, the Contractor will adjust manhole rings as directed by the Engineer. Manhole risers will be provided by the City and installed by the Contractor. The risers will be adjustable by a turnbuckle type locking device made by American Highway products or equal and will be placed just ahead of the paver so that they will not be affected by traffic. All such work shall be accomplished as ordered by the Engineer.

TS -6.11 USE OF EXPLOSIVES

Explosives will not be used on the work except when authorized by the Engineer. The use of some, if authorized, shall conform to laws or ordinances which may pertain to the use of same and the utmost care will be exercised by the Contractor so as not to endanger life or property. The Contractor will assume full responsibility in connection with use of any explosives even though authorized. Explosives will not be stored within the City limits.

TS -6.12 WATER FOR DUST CONTROL

The work specified in this section consists of the application of water within the limits of construction of the project or on streets used as detour routes in connection with the project, in accordance with these specifications.

Water used for dust control shall be free from pollution to the extent that its use will not constitute a nuisance or health hazard to anyone living in close proximity to the areas where it is used.

Water for dust control shall be included in the unit costs for the various items and no separate payment shall be made.

TS -6.13 WEATHER RESTRICTIONS

Absolutely no paving will occur in the event of rain. In the event that any resurfacing work is performed, all production will be discounted and payment will not be made. Only exception to this rule is if the contractor receives written instructions to pave over exposed base course.

Mixture shall be transported only when ambient air temperatures meet the artificial heat requirements in Table 330-1 in FDOT Standard Specifications for Road & Bridges, 2018.

TS -7.01 CONCRETE CURB OR CURB-AND-GUTTER

Expansion joints in concrete curb or curb-and-gutter shall be placed at all inlets, radius points, horizontal and vertical points of intersection (P.I.'s), and as otherwise directed by the Engineer. They shall be located at intervals of 100 feet between other expansion joints or ends of a run.

On any street that has been resurfaced and contains drainage inlets, the Contractor is required to maintain an eight-inch vertical opening to the inlet.

TS - 7.02 PAVEMENT REPLACEMENT AND TOTAL RESTORATION

No partial payment will be made for drainage structures, i.e., manholes, inlets, outfall structures, etc., and sanitary sewer, water or other reconstructed facilities until the total street replacement and complete restoration have been finished and accepted.

The limerock base shall be sealed and covered in accordance with F.D.O.T. Specifications, Section 300-2.2. Bare sand cover material will not be allowed unless the surface paving is scheduled and committed to be done no later than one week after the sealing. The Contractor shall keep the cover material surface in good condition and will not receive extra compensation for the cover material.

8.0 ANCILLARY OPERATIONS

TS -8.01 RESTORATION OF PRIVATE PROPERTY

The Contractor shall restore to its previous condition as directed by the Engineer any private property, City property, or utilities damaged by its construction. No payment shall be made to the Contractor for any required restoration of private property, City property or utilities, unless otherwise noted.

TS -8.02 RESTORATION OF LANDSCAPING WITHIN RIGHT-OF-WAY

The Contractor shall remove any shrubbery, trees less than 5 inches in diameter, other landscaping, walkways, planters, other landscaping, and irrigation systems which are in conflict with the proposed construction. These items shall be restored, relocated, and/or reconstructed as shown in the plans or as directed by the Engineer.

Cost of removing, restoring, relocating, and reconstructing the above items shall be included in the base bid. No separate payment shall be made for this item.

TS -8.03 RESTORATION OF EXISTING FENCE

The existing fence, if removed or damaged by the Contractor during the construction work in this project, shall be restored to its original condition.

No payment shall be made to the Contractor for the fence removal and/or restoration.

TS -8.04 TEMPORARY TRAFFIC STRIPING

Signalized intersections, school crossings, and four-way stop intersections shall receive special attention with temporary markings. Contractor shall be responsible for the striping plans during the project.

Temporary traffic striping used by the Contractor on surfaces, which will remain exposed roadway (final resurfacing course or friction course), shall be painted per FDOT Standard Specifications for Road & Bridges, 2018 Edition, Section 710, unless an alternative is approved by the City. All markings applied shall be in accordance with the Manual on Uniform Traffic Control Devices and in the final configuration as designed. The Engineer will provide a striping plan if new markings are to be installed to reconfigure the layout of the road. If no striping plan is available, the Contractor will re-install existing markings. Temporary reflective markers (RPM's) can be used if approved by the Engineer in writing.

Paint striping shall attain an initial retro-reflectivity of at least 450 mcd/lx.m² and 350 mcd/lx.m² for both White and Yellow striping, respectively.

TS -8.05 TEMPORARY STOCKPILING:

For temporary stockpiling of the excavated material within project limits (and anywhere within City limits) the Contractor shall follow the following procedure.

a. Public Right of Way - The Contractor will not be allowed to stockpile suitable, excavated material within right-of-way for a period in excess of 30 calendar days. Unsuitable excavated material shall not be stockpiled within public right-of-way for a period in excess of 7 calendar days.

b. Location other than Public Right-of-Way-

1. Obtain the permission (in writing) from the owner of the property where stockpiling is desired.
2. At its own expense, present the above letter and a contour plan of the site to the TSS Construction Engineer for approval of stockpiling site. Images documenting the before and after conditions should be taken by the Contractor with date stamped.
3. At the conclusion of the stockpiling activity, the Contractor shall obtain a signed letter of release from the property owner that he/she is completely satisfied with the stockpiling operation and with the restoration of their property. A copy of the letter shall be furnished to the City Pavement Management Engineer.

The time periods of stockpiling shall be specified by the Contractor in writing.

Upon removal of stockpiled material, the Contractor shall clean up and grade the site to its original contours and conditions.

The City of Tampa shall not be a party to any agreement between the Contractor and private property owner(s).

Regardless of the location of stockpiling, it shall be the Contractor's responsibility to make sure that stockpiling in no way constitutes a public hazard, nuisance and does not interfere with the natural surface runoff in the area. No additional payments shall be made for temporary stockpiling, or relocating stockpiling that is deemed a nuisance or public hazard by the Engineer.

TS -8.06 GRASSING AND/OR SODDING:

Lawn, road shoulders, and all areas that do not have well established grass at the time of construction and are disturbed during construction may be grassed, as directed by the Engineer. All areas shall be properly prepared by removal of construction debris and rocks, and soil preparation and fertilization or placement of topsoil as directed by the Engineer. Lawn, road shoulders, and other locations where construction shall occur that are well maintained and show healthy grass at the time of construction, or where otherwise directed by the Engineer, shall be sodded with either Pensacola or Argentine Bahia Type or St. Augustine type sod as applicable.

All areas that have a potential for being eroded by flowing surface water shall be sodded as directed by the Engineer including 2' adjacent to the new pavement edges.

TS -8.07 OTHER CONSIDERATIONS

The Contractor must have capability to flood any area with water to insure proper drainage upon completion of paving operations.

TS -8.08 DEWATERING

Any dewatering related to these projects will not be a separate bid item. The cost shall be included in the project pay items(s) associated with the work requiring the dewatering.

9.0 PEDESTRIAN

TS -9.01 EXISTING SIDEWALKS, DRIVEWAYS AND PARKING AREAS

The Contractor shall meet existing sidewalks, driveways and parking areas (concrete or asphalt) when possible with the proposed street replacement. At locations where existing sidewalks and driveways are not at the same elevations

as the new grades, the Contractor may be required to reconstruct a portion of the sidewalk or driveway as directed by the Engineer. (When existing driveway is of asphalt type, a base of 6" thickness shall be constructed with a 1.5" thick asphaltic concrete surface course.)

Payment for adjustments in driveways shall be made under Concrete Work (with the engineer's approval and authorization). There will be no payment if existing sidewalks or driveways must be reconstructed due to negligence or poor coordination and workmanship by the Contractor.

TS -9.02 PEDESTRIAN RAMPS

Title II of the Americans with Disabilities Act (ADA) requires that state and local governments ensure that persons with disabilities have access to the pedestrian routes in the public right of way. In the event when streets, roadways, or highways are altered, curb ramps shall conform to the PROWAG standards. Additional questions, please refer to FDOT Design Standards 2016, Index 304

The City will inventory and inspect the resurfacing areas for ADA compliance. A list will be provided to the Contractor to repair and modify any ramps according to the recommended curb ramp type. Curb ramps will be constructed according to the design specifications in FDOT Design Standards 2016, Index 304.

Detectable warnings shall extend the full width of the ramp and to a depth of 2'. Detectable warnings shall be constructed in accordance with Specification Section 527. Contractor will use detectable warning mats with truncated domes which follows the Americans with Disabilities Act Standards for Transportation Facilities, Section 705.

10.0 REPORTING

TS -10.01 MONTHLY CONSTRUCTION ESTIMATES AND RELEASE OF LIEN

The Contractor shall prepare on or about the first day of each month an estimate of the work completed in the preceding month. Said estimate shall be prepared on standard forms provided by the Engineer, and three (3) signed originals shall be provided by the Contractor. Any disputed quantities shall be adjusted as directed by the Engineer prior to each partial payment.

Certification that all subcontractors have been paid for the previous month's work shall be submitted with each partial payment request on forms provided by the Engineer.

An update of the overall project schedule shall be submitted with each partial payment request.

Progress will be reported and payment will be made for each paving area assigned by the City. If more than one paving area is active, each will be treated separately.

If a paving area consists of more than street or facility, then non-performance on any one street or facility within the paving area could be grounds for non-payment until the street or facility situation is satisfied to the satisfaction of the Engineer.

TS -10.02 BILLING / WORK ORDER EXAMPLE.

- Street Segment 200' Long X 22" Wide
- Square Yards (220' x 22")/ 9 = 488 sq yds
- City presents Work Order for Segment:
- Estimate Yards @ 488 sq yds
- Estimate 110 lbs/yd² of Asphalt
- Estimate of Units:

- Area..... 488 Sq Yds
- Asphalt. 26.8 Tons
- (110 lbs. x 488 sq yds) 2000 lbs/Ton = 26.8 Tons
- Range of Acceptable Billing at +/- 5 lbs./Ton:
- @ 105 lbs/sq yd..... 25.6 Tons x Unit Price
- @ 110 lbs/sq yd..... 26.8 Tons x Unit Price
- @ 115 lbs/sq yd..... 28.0 Tons x Unit Price
- Work Orders and Daily Work Summary

Reporting shall be grouped by On-Street location and associated quantitative value.

The Contractor and the Inspector shall be required to mutually agree (prior to the work) as to the amount of (average lbs/sq yd) asphalt that is to be used for each work area. A Work Order will be used to document this amount and then be used as the base for calculating the acceptable range of the billing (+/- 5 lbs per sq yd). No work is to commence before the Contractor and the Engineer has signed said Work Order.

At the end of each workday, the Contractor and the Engineer shall confirm and document the square yards of asphalt and the tons of asphalt used for that day. Said documentation shall be performed on the Daily Work Summary Form to be signed by both parties. As the work proceeds, the Contractor shall provide the Engineer with asphalt shipping tickets that provide the tonnage amount and square yardage so that at the end of the day, the pounds per square yard of asphalt for that day can be documented on the Daily Work Summaries.

TS -10.03 QUANTITY

The quantities specified in the Bid Response Page are approximate. Payment will be based on actual field measurement agreed to daily by the Engineer and Contractor. No minimum area is required for any resurfacing area. However, additional payment will be made for project areas <5,000 SY.

TS -10.04 DENSITY REQUIREMENTS

If the Contractor places within +/- 5 lbs. per sq. yd. of the amount of asphalt specified by the City, then the City shall pay said Contractor for the exact amount of asphalt placed.

If the actual amount of asphalt placed by the Contractor is greater than the +/- 5 lbs. per sq. yd. range specified above, then the Engineer will be given the following two options:

- (1) The work shall be deemed unacceptable and the Contractor shall be required to rework the entire work area so as to comply with the work order. There shall be no additional compensation for this work;
- (2) The Engineer may elect to pay the Contractor for the amount of asphalt actually placed.

If the actual amount of asphalt placed by the Contractor is greater than the amount of asphalt +/- 5 lbs. per sq. yd., then the City shall pay for only the specified amount plus 5 lbs. per sq. yd.

TS -10.05 STOCKPILING

The time periods of stockpiling shall be specified by the Contractor in writing.

11.0 DAMAGE REMEDIATION

Non-performance on any paving area could be grounds for termination of all active paving area assignments, at the discretion of the City.

TS -11.01 EXISTING PUBLIC FACILITIES

Existing public facilities that are removed by construction operations under this contract shall be replaced by the Contractor to City of Tampa specifications. These items shall include all public benches, light poles, shelters, roadway signs, etc., and replacement of these items shall be considered incidental to the cost of construction and no separate payment will be made.

TS -11.02 DAMAGE TO ADJACENT STREETS

Any streets, including curbs, gutters and shoulders, outside the project area (not designated for construction), which are determined by the Engineer to have been damaged due to negligent construction related operations and/or equipment, shall be restored by the Contractor to its original or better condition without any cost to the City and to the satisfaction of the Engineer.

TS -11.03 RESTORATION OF MONUMENTATION

The Contractor shall, with no additional payment, re-establish any permanent monumentation which is disturbed or destroyed in the course of the construction project.

TS -11.04 PROJECT CLEAN UP

If project cleanliness and/or dust control reaches an unacceptable level in the opinion of the Engineer, the Engineer will notify the Contractor in writing. If the Contractor does not act to correct the situation within 4 hours in the case of dust control or within 24 hours in the case of general cleanliness, the Engineer will call upon outside forces to provide the appropriate services. Cost of all such activities shall be charged to the Contractor via Award change order.

TS -11.05 CONTINGENCY ALLOWANCE

Payment from the Contingency Allowance shall be made only at the direction of the Engineer under:

TS -11.06 COMPLIANCE WITH TIME REQUIREMENTS

The Contractor shall complete work in accordance with the schedule provided at the pre-construction conference. Documentation will be provided each month to demonstrate compliance with the schedule for each paving area.

In the event that the schedule is different from what has been previously provided, the Contractor shall provide documentation supporting the differences. If the project is behind schedule, the Contractor shall provide a schedule recovery plan and/or amended schedule to demonstrate how the project will proceed.

If the construction schedule is not met due to negligence or poor planning, the amount established in Liquidated Damages may be applied. Any delays caused by natural disasters or environmental factors shall excuse the contractor to extend the project timeline.

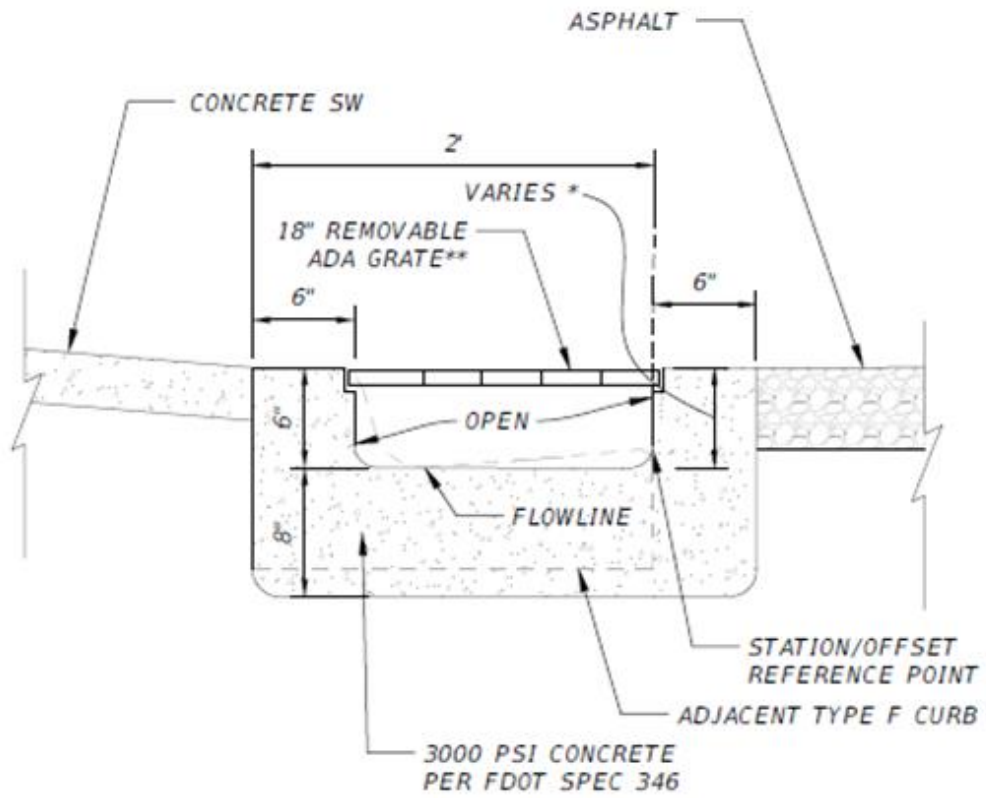



Page 1 of 2 –DMI Payment
City of Tampa – DMI Sub-(Contractors/Consultants/Suppliers) Payments
(FORM MBD-30)

[] Partial [] Final

Contract No.: _____ WO#,(if any): _____ Contract Name: _____

Contractor Name: _____ Address: _____

Federal ID: _____ Phone: _____ Fax: _____ Email: _____

GC Pay Period: _____ Payment Request/Invoice Number: _____ City Department: _____

Total Amount Requested for pay period: \$ _____ Total Contract Amount(including change orders):\$ _____

Type of Ownership - (F=Female M=Male), BF BM = African Am., HF HM = Hispanic Am., AF AM = Asian Am., NF NM = Native Am., CF CM = Caucasian S = SLBE

Type	Trade/Work Activity	Federal ID	Total Sub Contract Or PO Amount	Amount Paid To Date	Amount To Be Paid For This Period
[]Sub []Supplier				Amount Pending Previously Reported	Sub Pay Period Ending Date
				\$	\$
				\$	\$
				\$	\$
				\$	\$
				\$	\$
				\$	\$

(Modifying This Form or Failure to Complete and Sign May Result in Non-Compliance)

Certification: I hereby certify that the above information is a true and accurate account of payments to sub – contractors/consultants on this contract.

Signed: _____ Name/Title: _____ Date: _____



Page 2 of 2 – DMI Payment

Instructions for completing The DMI Sub-(Contractors/Consultants/ Suppliers) Payment Form (Form MBD-30)

This form must be submitted with all invoicing or payment requests where there has been subcontracting rendered for the pay period. If applicable, after payment has been made to the subcontractor, “Waiver and Release of Lien upon Progress Payment”, “Affidavit of Contractor in Connection with Final Payment”, or an affidavit of payment must be submitted with the amount paid for the pay period. The following will detail what data is required for this form. The instructions that follow correspond to the headings on the form required to be completed. **(Modifying or omitted information from this form my result in non-compliance).**

- **Contract No.** This is the number assigned by the City of Tampa for the bid or proposal.
- **W.O.#** If the report covers a work order number (W.O.#) for the contract, please indicate it in that space.
- **Contract Name.** This is the name of the contract assigned by the City of Tampa for the bid or proposal.
- **Contractor Name.** The name of your business.
- **Address.** The physical address of your business.
- **Federal ID.** A number assigned to a business for tax reporting purposes.
- **Phone.** Telephone number to contact business.
- **Fax.** Fax number for business.
- **Email.** Provide email address for electronic correspondence.
- **Pay Period.** Provide start and finish dates for pay period. (e.g. 05/01/13 – 05/31/13)
- **Payment Request/Invoice Number.** Provide sequence number for payment requests. (ex. Payment one, write 1 in space, payment three, write 3 in space provided.)
- **City Department.** The City of Tampa department to which the contract pertains.
- **Total Amount Requested for pay period.** Provide all dollars you are expecting to receive for the pay period.
- **Total Contract Amount (including change orders).** Provide expected total contract amount. This includes any change orders that may increase or decrease the original contract amount.
- **Signed/Name/Title/Date.** This is your certification that the information provided on the form is accurate.
- **See attached documents.** Check if you have provided any additional documentation relating to the payment data. Located at the bottom middle of the form.
- **Partial Payment.** Check if the payment period is a partial payment, not a final payment. Located at the top right of the form.
- **Final Payment.** Check if this period is the final payment period. Located at the top right of the form.

The following instructions are for information of any and all subcontractors used for the pay period.

- **(Type) of Ownership.** Indicate the Ethnicity and Gender of the owner of the subcontracting business or SLBE.
- **Trade/Work Activity.** Indicate the trade, service, or material provided by the subcontractor.
- **SubContractor/SubConsultant/Supplier.** Please indicate status of firm on this contract.
- **Federal ID.** A number assigned to a business for tax reporting purposes. This information is critical in proper identification of the subcontractor.
- **Company Name, Address, Phone & Fax.** Provide company information for verification of payments.
- **Total Subcontract Amount.** Provide total amount of subcontract for subcontractor including change orders.
- **Amount Paid To Date.** Indicate all dollars paid to date for the subcontractor.
- **Amount Pending, Previously Reported.** Indicate any amount previously reported that payments are pending.
- **Amount To Be Paid for this Period.** Provide dollar amount of dollars requested for the pay period.
- **Sub Pay Period Ending Date.** Provide date for which subcontractor invoiced performed work.

Forms must be signed and dated or will be considered incomplete. The company authorized representative must sign and certify the information is true and accurate. Failure to sign this document or return the document unsigned can be cause for determining a company is in non-compliance of Ordinance 2008-89.

If any additional information is required or you have any questions, you may call the Minority Business Development Office at (813) 274-5522.

0 1 2 3 4 5 6 7 8

Sign Information

Building a Better Tampa

**David L. Tippin Water Treatment Facility
Caustic Soda Piping Improvements**

Project provides for Improvements at the David L. Tippin Water Treatment Facility to Improve the reliability and safety of the Sodium Hydroxide System of the water distribution system within the facility.

\$TBD investment
Scheduled for completion in TBD 2014

TBD

Colors

Blue: Sherwin Williams Naval SW6244
Green: Sherwin Williams Center Stage SW 6920
White: Sherwin Williams Pure White SW7005

Font

Franklin Gothic

SIGN EXAMPLE ONLY GRAPHIC TO BE DEVELOPED BY CONTRACTOR

not to scale

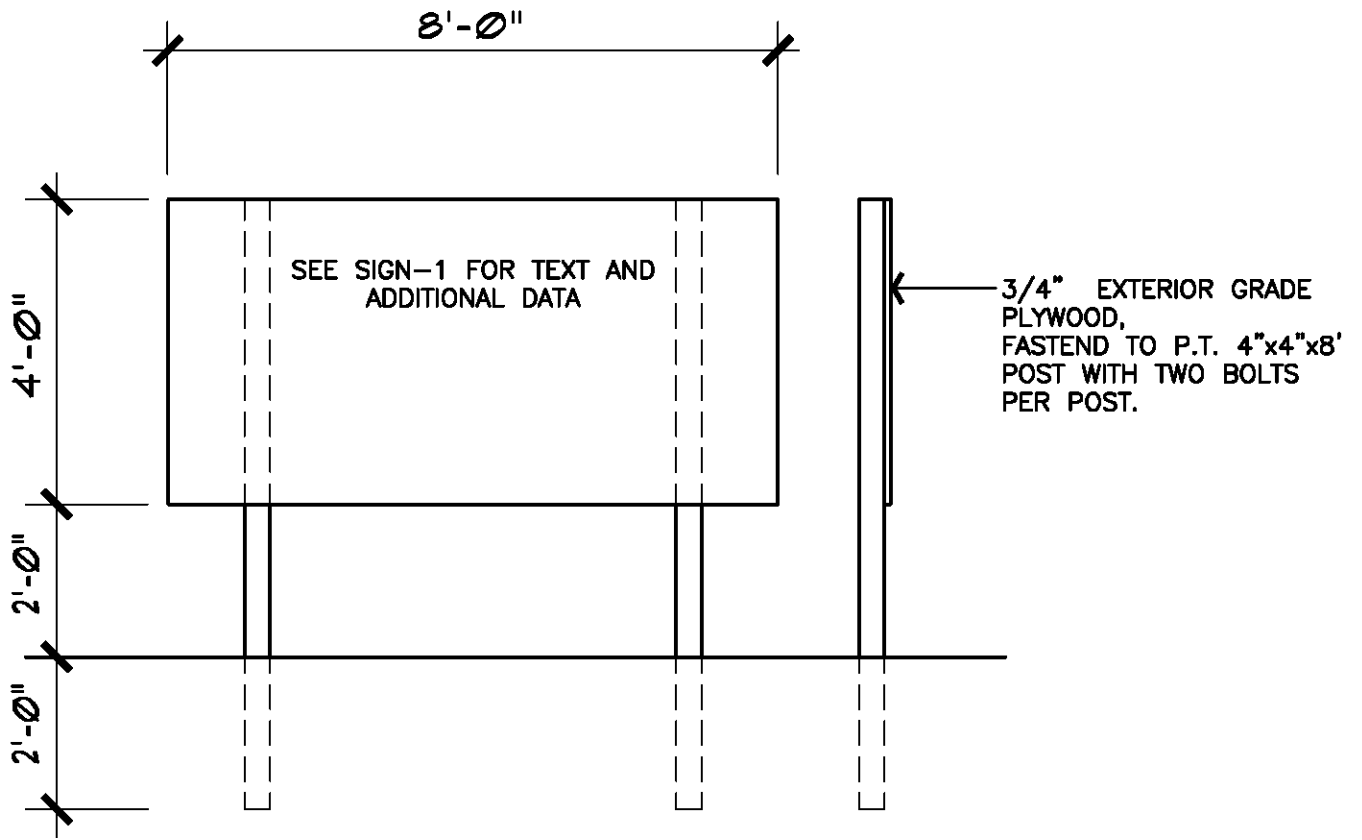

WORKMANSHIP AND MATERIALS

SECTION 425 - STORMWATER INLETS, MANHOLES AND JUNCTION BOXES

W-425.01 General

The work specified in this section consists of the construction of inlets, manholes, junction boxes, shoulder gutter inlets, and yard drains. These structures shall be of reinforced concrete, or may be of brick masonry if circular and constructed in place, and shall include the necessary metal frames and gratings. The work under this section shall also include the adjustment of those structures shown in the plans to be adjusted or which are required to be adjusted for the satisfactory completion of the work. The new structures shall be constructed in conformity with the plans and in accordance with these specifications.

W-425.02 Composition and Proportioning

Concrete: Unless otherwise shown in the plans, all concrete for these structures shall be Class II as specified in Section 345.

Mortar: The mortar for brick masonry shall be of portland cement and sand, mixed in the proportions of one part cement to two parts of sand. Miami Oolitic rock screenings may be substituted for the sand upon prior approval of the Engineer. All the materials shall pass the No. 8 Sieve, and be uniformly graded from coarse to fine. At the option of the Contractor, hydrated lime, in an amount not to exceed ten percent of the amount of cement used, may be added to the mortar.

As an alternate to the above, masonry cement may be used in lieu of the above-specified mortar provided that it is delivered in packages properly identified by brand name of manufacturer, net weight of package, and whether it is Type 1 or Type 2, and further provided that it has not been in storage for a period greater than six months. Hydrated lime shall not be used with masonry cement.

The sand and cement shall be thoroughly mixed dry in proper boxes or mortar mixers and such quantity of clean fresh water added as will provide a stiff mortar of the proper consistency. The whole mass shall be thoroughly mixed until used. Any mortar that has set shall not be retempered in any way, and no mortar shall be used more than one and one-half (1-1/2) hours after mixing.

W-425.03 Gratings

Gratings and frames fabricated from structural steel shall be galvanized in accordance with the requirements of ASTM A123 or shall be painted with two coats of prime meeting the requirements of Section 971-8 of the Standard F.D.O.T. Specifications for Road and Bridge Construction, followed by one coat of material meeting the requirements of Federal Specification TT-E-489, Class A Black. All paint may be applied in the shop, by dipping, provided that each coat is thoroughly dry before the succeeding coat is applied. These requirements do not apply when A-588 steel is used.

When Alternate "G" grates are specified, the chain, bolt, nuts, and cold shuts shall be galvanized after fabrication in accordance with the requirements of ASTM A 123.

W-425.04 Forms

Forms shall be of wood or metal, so designed and constructed that they may be removed without injury to the concrete. They shall be built true to line and grade and braced in a substantial and unyielding manner, and shall be approved by the Engineer before being filled with concrete.

W-425.05 Precast Inlets, Manholes, and Junction Boxes

Careful attention shall be given to the proper construction or reconstruction of the pavement adjacent to the gutters and at street intersections to obtain satisfactory drainage to the inlets from the intersecting streets.

The Contractor may request to substitute precast inlets, manholes, and junction boxes in lieu of cast-in-place units unless otherwise shown in the plans or directed by the Engineer. At locations not so restricted, the Contractor shall carefully examine the plan details at each structure to determine if use of a precast unit is feasible. The design and fabrication of precast units shall be in accordance with the standard index drawings, which may allow use of designs other than those detailed in the standard index drawings.

Smooth welded wire fabric may be substituted for deformed re-bar or welded deformed wire reinforcement in non-circular precast drainage structures provided the following requirements are met:

1. The smooth welded wire fabric shall comply with ASTM A-185.
2. Substitution of equal areas of smooth wire fabric for the reinforcing steel and provided the width and length of the unit is four times the width of the spacing of the cross wires.
3. Wire shall be continuous around the box and spliced at a quarter point of one side with an overlap of not less than the spacing of the cross wires plus two inches.

W-425.06 Construction Methods

Excavation: Excavation shall comply with the requirements specified in Section 1.

Placing and Curing Concrete: The concrete shall be placed in the forms, to the depth shown in the plans and thoroughly vibrated. After the concrete has hardened sufficiently, it shall be covered with suitable material approved by the Engineer, and kept moist for a period of three days.

Setting Manhole Castings: After the concrete has been cured as specified above, the frame of the casting shall be set in a full mortar bed composed of one part portland cement to two parts of fine aggregate.

Reinforcing Steel: The construction methods for the steel reinforcement shall be as specified in Section 6.

Laying Brick: All brick shall be saturated with water before being laid. The brick shall be laid by the shovejoint method so as to bond them thoroughly into the mortar. Headers and stretchers shall be so arranged as to bond the mass thoroughly. Joints shall be finished properly as the work progresses and shall be not less than 1/4 inch or more than 3/4 inch in thickness. No spalls or bats shall be used except for shaping around irregular openings or when unavoidable at corners.

The inside of the brick masonry walls shall be plastered uniformly with cement mortar one-half (1/2) inch in thickness mixed in proportions of one part of cement and two parts of clean, sharp sand.

Placing Pipe: Inlet and outlet pipes shall be of the same size and kind as the connecting pipe shown in the plans. They shall extend through the walls for a distance beyond the outside surface sufficient for the intended connections, and the concrete shall be constructed around them neatly so as to prevent leakage along their outer surface. The inlet and outlet pipes shall be flush with the inside of the wall.

Backfilling: Backfilling shall conform with the requirements specified in Section 2.

Adjusting Existing Structures: Existing manholes, catch basins, inlets, valve boxes, monument boxes, etc., within the limits of the proposed work, that do not conform to the finished grade of the proposed pavement, or to the finished grade designated on the plans for such structures, shall be cut down or extended, and made to conform to the grade of the new pavement, or to the designated grade of the structure if outside of the proposed pavement area. The materials and construction methods for this work shall conform to the requirements specified above.

Where manholes are to be raised, the adjustment may, at the Contractor's option, be made by the use of adjustable extension rings of the type which do not require the removal of the existing manhole frame. The extension device shall provide positive locking action and shall permit adjustment in height as well as diameter. The particular type of device used shall meet the approval of the Engineer.

Adjusting Structures: When an item of payment for adjusting manholes, valve boxes, inlets, or monument boxes is provided in the proposal, the number of such structures designated to be paid for under separate items, and which are satisfactorily adjusted, shall be paid for at the contract units prices each for Adjusting Inlets, Adjusting Manholes, Adjusting Valve Boxes, and Adjusting Monument Boxes.

For any of such types of these structures required to be adjusted but for which no separate item of payment is shown in the proposal for the specific type, payment shall be made under the item of Adjusting Miscellaneous Structures.

W-425.07 Drainage Structures

1. All inlets, manholes, and junction boxes shall, unless otherwise directed by the Engineer, be constructed as per design plans and applicable design standards. All manholes shall be Traffic Bearing type. It shall be the responsibility of the Contractor to assure that the designated sizes of the drainage structures meet the following criteria:

- a. The minimum distance from the top of the opening for the highest pipe to the bottom of the top slab shall be ten inches (10"); 12 inches from top of pipe to bottom of top slab, before "stack" is used.
 - b. The minimum diameter for stack heights shall be thirty-six (36) inches.
 - c. The minimum distance between pipe openings shall be nine (9) inches.
 - d. For four-sided structures having openings in more than one corner, individual shop drawings must be submitted for prior approval.
2. If warranted by field conditions and directed by the Engineer, the Contractor shall, at such locations, construct brick drainage structures (in place of concrete drainage structures), according to the standards specified below:

Brick construction shall be as follows:

- a. Wall thickness minimum eight inches (8") up to eight feet (8') height, unless specified otherwise.
 - b. Wall thickness minimum twelve inches (12") up to twelve feet (12') height, unless specified otherwise.
 - c. Brick shall be laid in 1:2 (Portland cement-sand) mortar.
 - d. Before laying the bricks in mortar, the bricks shall be thoroughly sprinkled with clean water (not to saturation extent).
 - e. Brick for manhole and inlet structures shall be laid in stretcher courses, with every sixth course a header course.
 - f. All brick structures shall be plastered smooth inside also with 1/2-inch thick, 1:2 (Portland cement-sand) mortar.
 - g. No "unsound" brick shall be used. As a test, if a light hammer blow, with the brick held lightly in hand, does not produce a uniform crisp ringing sound, the brick shall be construed to have crack(s), or otherwise unsound and shall be rejected.
 - h. All bricks shall be solid.
3. No additional compensation shall be paid for brick structures. Brick and concrete shall not be used simultaneously in drainage structure walls. Walls of round structures shall be constructed of concrete only.
4. For all types of manholes, the top and bottom slab shall be as per applicable D.O.T. standards, even if brick is allowed to be used in the manhole walls. The following criteria shall apply to slab thicknesses and steel reinforcements:

- a. Top and bottom slabs shall have same thicknesses and reinforcements in any manhole structure.
 - b. The minimum slab thickness and reinforcement shall be 8 inches thick and #6 bars at 6-inch centers both ways.
 - c. 4-foot by 6-foot (4' x 6') or larger manholes, including circular manholes with inside diameter of 5-feet (5.0') or larger, shall have 10-inch thick slabs with #7 bars at 6-inch centers both ways.
 - d. Unless specified on the Plans, four-sided structures with both inside dimensions in excess of eight feet (8.0') and circular structures with inside diameter in excess of eight feet (8.0') shall not be covered by D.O.T. and the above criteria.
5. All grate inlets shall conform to the City of Tampa design standards.
 6. Grates on inlets, as well as all other structures, shall be Traffic Bearing Type, unless specified otherwise, and subject to approval of the Engineer. All grate inlets shall be fitted with an approved metal frame at the top to seat the grates.
 7. All Type-P manholes shall be bid at one average unit price regardless of size and shape. Similarly, all Type-J manholes will be bid at one average unit price regardless of size and shape unless indicated otherwise in the proposal.
 8. The reinforcements and shapes for all drainage structures, unless directed by the Engineer otherwise, shall conform to the Plans and applicable design standards.
 9. Vertical support columns (one in case of Type 5 inlet) shall be constructed by the Contractor, as a part of the D.O.T. Type 5 and 6 curb inlets, where and as directed by the Engineer.
 10. The Contractor, if so directed by the Engineer in order to better meet site requirements, shall construct B-S-1, B-R-2, B-V-1, or B-R-1 type curb inlets in lieu D.O.T. Type 5 and 6 inlets and vice-versa without additional cost to the City. P-5 and P-6 inlets shall have 3-1/2-foot by 3-1/2-foot substructures unless oversize pipe is to be accommodated or otherwise directed by the Engineer. Legible, detailed plans of each inlet type shall be provided to the Contractor.
- Side openings in curb and grate type inlets may be specified in the Plans or by the Construction Engineer to meet site conditions. The Contractor shall provide such openings without any additional cost.
11. When precast drainage structures are requested as substitutions for poured in place concrete structures, the Contractor shall meet the following additional requirements:
 - a. Minimum height of the base structure (manhole or inlet barrel), unless restricted by design, shall be 5 feet 0 inches before extending the structure height by another precast "barrel." The minimum height of the top (extension) precast "barrel" shall be 1 foot 6 inches. "Barrel" extensions of less than 1-foot 6-inch height shall be cast

in place with continuous reinforcement.

- b. Four-sided structures may be considered as an alternate to circular structures, but not the reverse.
- c. For substructures for the City-type curb inlets, unless specified otherwise, directed by the Engineer, or to accommodate larger pipes, the Contractor may use a 3-foot by 4-foot (inside dimensions) structure. This structure shall have same slab and wall thicknesses and steel reinforcing as specified for "Type E" grate inlet.
- d. When circular structures are precast in accordance with ASTM C-478, minimum wall thickness shall be six inches (6") thick or as specified in ASTM C-478 for larger diameter structures.
- e. The location of the pipe holes and adequate basic substructures height, unless directed otherwise by the Engineer, shall be the responsibility of the Contractor.
- f. The Contractor shall submit shop drawings only as specified below:
 - (1) One each-typical for different type of structures.
 - (2) For structures directed by the Engineer, and/or requiring change with respect to design plans, or as otherwise required by these specifications.
- g. Provide schedule of manufacture of the structures. No compensation shall be paid to the Contractor for unusable precast drainage structures.
- h. Provide material testing acceptance reports by a licensed private laboratory verifying:
 - (1) that the structures were constructed in accordance with details shown on the Plans and/or Shop Drawings;
 - (2) the exact design criteria adhered to; if more than one, identify which criteria applies to which structures;
 - (3) the project title, project number, file number, date cast, structure, plan sheet number and station;
 - (4) reinforcement size, spacing and amount;
 - (5) concrete placement, curing and strength, and verification of concrete cover on reinforcement; and
 - (6) that the testing laboratory stamp is placed on each structure prior to shipment.
- i. Cooperate with Department personnel regarding periodic inspection of the precast units and the precast operations.

12. All manhole and inlet structures shall be set on a minimum 6-inch thick layer of compacted number 57 size coarse aggregate unless noted otherwise in the Plans or Specifications, or unless the Engineer determines a thicker layer is required due to soil and/or water conditions. All such coarse aggregate shall be completely enveloped in non-woven filter fabric as directed by the Engineer.

Payment for the 6-inch thick layer of stone shall be included in the price of the structure. Payment for thicker layers of stone shall be made from the select bedding material (stone) pay item, if available, or as extra work.

13. All casting covers, such as for inlets and manholes, shall bear the appropriate City of Tampa identification for storm sewers and for sanitary sewers, as shown on the Plans and directed by the Engineer.

* * *